

**PDP-11/05,11/10
computer manual**

pdp11

digital

**PDP-11/05,11/10
computer manual**

1st Edition, February 1973
2nd Printing, September 1973
3rd Printing, July 1974
4th Printing, September 1974

Copyright © 1973, 1974 by Digital Equipment Corporation

The material in this manual is for informational purposes and is subject to change without notice.

Printed in U.S.A.

The following are trademarks of Digital Equipment Corporation, Maynard, Massachusetts:

DEC	PDP
FLIP CHIP	FOCAL
DIGITAL	COMPUTER LAB
UNIBUS	

CONTENTS

Page

PART 1 – COMPUTER DESCRIPTION

CHAPTER 1 COMPUTER COMPONENTS

1.1	Introduction	1-1
1.2	Computer Components	1-1
1.2.1	KD11-B Processor	1-1
1.2.2	Core Memory	1-1
1.2.2.1	Memory Organization	1-2
1.2.2.2	Memory Specification	1-2
1.2.3	Power Supply	1-2
1.2.4	Backplane	1-2
1.3	ME11-L Core Memory System	1-5
1.4	Extension Mounting Box	1-5

CHAPTER 2 UNIBUS

2.1	Introduction	2-1
2.2	Unibus Structure	2-1
2.2.1	Bidirectional Lines	2-1
2.2.2	Master/Slave Relationship	2-1
2.2.3	Interlocked Communication	2-2
2.3	Peripheral Device Organization and Control	2-2
2.4	Unibus Control Arbitration	2-2
2.4.1	Priority Transfer Requests	2-2
2.4.2	Processor Interrupts	2-3
2.4.3	Data Transfers	2-3

CHAPTER 3 UNPACKING AND INSTALLATION

3.1	Introduction	3-1
3.2	Unpacking	3-1
3.3	Mechanical Description	3-1
3.4	Installation	3-6
3.4.1	Mounting Computer on Installed Slides	3-6
3.4.2	Securing Computer to Cabinet Rack	3-6
3.4.3	Installation of I/O Cables	3-6
3.5	Interchangeable Peripheral Slots	3-7
3.6	Side and Top Cover Installation	3-7
3.7	AC Power Supply Connection	3-7
3.7.1	Connecting to Voltages Other than 115V	3-7
3.7.2	Quality of AC Power Source	3-7
3.8	Cabinet Power Control	3-7
3.9	Installation Certification	3-8
3.10	Warranty Service (Domestic Only)	3-9

CONTENTS (Cont)

	Page
CHAPTER 4	COMPUTER OPERATION
4.1	Introduction 4-1
4.2	Power Switch Operation 4-1
4.3	Function Switches 4-2
4.4	Address/Data Switches 4-2
4.5	Console Indicators 4-2
4.6	Console Operation 4-2
4.6.1	Load Address Switch 4-2
4.6.2	Examine Switch 4-2
4.6.3	Deposit Switch 4-4
4.6.4	ENABLE/HALT Switch 4-4
4.6.5	START Switch 4-4
4.6.6	Continue Switch 4-5
4.7	Unconditional Computer and Unibus Initialization 4-5
4.8	Loading Programs from Paper Tape 4-5
4.8.1	The Bootstrap Loader 4-6
4.8.1.1	Loading the Loader Into Memory 4-7
4.8.1.2	Loading Bootstrap Tapes 4-8
4.8.1.3	Bootstrap Loader Operation 4-9
4.8.2	The Absolute Loader 4-10
4.8.2.1	Loading the Loader Into Memory 4-10
4.8.2.2	Loading Absolute Tapes 4-10
4.8.3	Memory Dumps 4-12
4.8.3.1	Operating Procedures 4-12
4.8.3.2	Output Formats 4-13
4.8.3.3	Storage Maps 4-13
PART 2 – KD11-B PROCESSOR	
CHAPTER 5	PROCESSOR GENERAL DESCRIPTION
5.1	Introduction 5-1
5.2	KD11-B Definition 5-1
5.3	KD11-B and the Unibus 5-1
5.4	KD11-B as an Instruction Interpreter 5-2
5.5	KD11-B Print Set 5-3
5.5.1	Medium and Large Scale Integrated Circuit Representations 5-5
5.5.2	Microprogram Documentation 5-5
5.5.3	Read-Only Memory (ROM) Maps 5-5
CHAPTER 6	INSTRUCTION SET
6.1	Introduction 6-1
6.2	Addressing Modes 6-1
6.2.1	Introduction 6-1
6.2.2	Instruction Timing 6-2
6.3	PDP-11/05 Instructions 6-2
6.4	Instruction Set Differences 6-2

CONTENTS (Cont)

	Page
CHAPTER 7	CONSOLE DESCRIPTION
7.1	Introduction 7-1
7.2	General Description 7-1
7.2.1	ADDRESS/DATA Register Logic 7-1
7.2.2	Control Switch Logic 7-1
7.3	Detailed Description 7-2
7.3.1	Multiplexer 7-2
7.3.2	Clock 7-3
7.3.3	Counter 7-4
7.3.4	Display Buffer and Driver 7-6
7.3.5	Control Switches and Logic 7-7
7.3.5.1	Normal Operating Mode 7-8
7.3.5.2	Panel Lock Mode 7-9
7.3.5.3	Power Loss During Operation 7-9
CHAPTER 8	KD11-B DETAILED DESCRIPTION
8.1	Introduction 8-1
8.2	ROMs as Generalized Gates 8-1
8.3	KD11-B Data Path, Simplified Description 8-3
8.3.1	Data Path (DP) Detailed Description 8-3
8.3.2	DP Data Polarities 8-3
8.3.3	Data Path Control (DPC) 8-4
8.3.4	A-Multiplexer 8-4
8.3.5	Arithmetic Logic Unit (ALU) 8-7
8.3.6	B Register 8-10
8.3.6.1	Functional Description 8-10
8.3.6.2	BLEG Operations That Provide Input to the ALU 8-13
8.3.6.3	BREG Shifting Operations 8-14
8.3.7	Byte Instructions 8-16
8.3.8	Scratch Pad Memory 8-16
8.3.9	Scratch Pad Memory Address Multiplexer 8-19
8.3.10	Processor Status Word Register 8-20
8.3.11	Constants Generator 8-26
8.3.12	Console Switch Register 8-26
8.3.13	Console Multiplexer 8-27
8.4	Instruction Decoding 8-28
8.4.1	Introduction 8-28
8.4.2	Double Operand Instructions 8-28
8.4.3	Branch on Unary 8-30
8.4.4	PDP-11 Branch Instruction 8-30
8.4.5	Operate Instructions 8-30
8.4.6	Auxiliary ALU Control 8-30
8.5	Processor Clock 8-31
8.6	Unibus Control 8-33
8.6.1	DATI Timing 8-33
8.6.2	DATI Operation 8-34
8.6.2.1	DATIP Operation 8-35
8.6.2.2	DATIP Logic 8-36

CONTENTS (Cont)

	Page
8.6.3	DATO 8-36
8.6.4	Byte Operations 8-36
8.6.5	Bus Errors 8-37
8.7	Internal Unibus Addresses 8-37
8.8	Bus Requests 8-39
8.9	Non-Processor Requests (NPR) 8-41
8.10	Serial Communications Line Description (SCL) 8-41
8.11	Line Clock 8-43
8.11.1	Introduction 8-43
8.11.2	Flag Control 8-43
8.11.3	Interrupt Control 8-44
8.12	Power Fail 8-45
 CHAPTER 9 MICROPROGRAM CONTROL	
9.1	Introduction 9-1
9.2	Microprogrammed Versus Conventional Control 9-1
9.3	Control Store 9-1
9.4	Branching Within Microroutines 9-7
9.5	Microprogram Flow 9-10
9.5.1	Flow Chart Notation 9-11
9.5.2	Interrupts and Traps 9-17
9.5.3	Console Functions 9-18
9.6	Microprogram Symbolic Listing 9-20
9.7	Microprogram Binary Listing 9-20
9.8	Microprogram Cross Reference Listing 9-24
 CHAPTER 10 KD11-B AND CONSOLE MAINTENANCE	
10.1	Introduction 10-1
10.2	Diagnostics 10-1
10.3	Types of Failures 10-1
10.4	Suggested Equipment 10-1
10.5	Procedures 10-2
10.6	Adjustments 10-3
10.7	KD11-B Print Function Table 10-4
10.8	External Clock Inputs 10-6
10.9	KM11 Maintenance Panel 10-6
10.10	Using KM11 Maintenance Panel 10-9
10.11	Console Maintenance 10-10
 PART 3 – MM11-K AND MM11-L MEMORIES	
 CHAPTER 11 MM11-K AND L GENERAL DESCRIPTION	
11.1	Introduction 11-1
11.2	General Description 11-1
11.2.1	Physical Description 11-1
11.2.2	Specifications 11-1
11.2.3	Functional Description 11-4

CONTENTS (Cont)

	Page
11.2.3.1	G110 Control Module 11-4
11.2.3.2	G231 Driver Module 11-6
11.2.3.3	H213 or H214 Stack Module 11-6
11.2.4	Basic Memory Operations 11-7
11.2.4.1	Data In (DATI) Cycle 11-7
11.2.4.2	Data In, Pause (DATIP) Cycle 11-7
11.2.4.3	Data Out (DATO) Cycle 11-7
11.2.4.4	Data Out, Byte (DATOB) Cycle 11-7
 CHAPTER 12 MM11-K AND L DETAILED DESCRIPTION	
12.1	Introduction 12-1
12.2	Core Array 12-1
12.3	Memory Operation 12-1
12.4	Device and Word Selection 12-4
12.4.1	Memory Organization and Addressing Conventions 12-6
12.4.2	Device Selector 12-8
12.4.3	Word Selection 12-11
12.4.3.1	Word Address Register and Gating Logic 12-12
12.4.3.2	X- and Y-Line Decoding 12-13
12.4.3.3	Drivers and Switches 12-15
12.4.3.4	Word Address Decoding and Selection Sequence 12-17
12.5	Read/Write Current Generation and Sensing 12-19
12.5.1	Read/Write Operations 12-19
12.5.2	X- and Y-Current Generators 12-21
12.5.3	Inhibit Driver 12-22
12.5.4	Sense Amplifier 12-23
12.5.5	Memory Data Register 12-24
12.6	Stack Discharge Circuit 12-24
12.7	DC LO Circuit 12-26
12.8	Operating Mode Selection Logic 12-26
12.9	Control Logic 12-27
12.9.1	Timing Circuit 12-28
12.9.2	Slave Synchronization (SSYN) Circuit 12-33
12.9.3	Pause/Write Restart Circuit 12-34
12.9.4	Strobe Generating Circuit 12-37
12.9.5	Data In (DATI) Operation 12-39
12.9.6	Data In Pause (DATIP) Operation 12-41
12.9.7	Data Out (DATO) Operation 12-41
12.9.8	Data Out Byte (DATOB) Operation 12-41
 CHAPTER 13 MEMORY MAINTENANCE	
13.1	Introduction 13-1
13.2	Preventive Maintenance 13-1
13.2.1	Initial Procedures 13-1
13.2.2	Checking Output of Current Generators 13-2
13.3	Corrective Maintenance 13-2
13.3.1	Strobe Delay Check and Adjustment 13-2
13.3.2	Corrective Maintenance Aids 13-2

CONTENTS (Cont)

	Page
13.4	Programming Tests 13-9
13.4.1	Address Test Up (MAINDEC-11-DIAA) 13-9
13.4.2	Address Test Down (MAINDEC-11-DIBA) 13-9
13.4.3	No Dual Address Test (MAINDEC-11-DICA) 13-9
13.4.4	Basic Memory Patterns Test (MAINDEC-11-DIDA) 13-9
13.4.5	Worst-Case Noise Test (MAINDEC-11-DIGA) 13-10

PART 4 – POWER SUPPLY

CHAPTER 14 POWER SUPPLY GENERAL DESCRIPTION

14.1	Introduction 14-1
14.2	Physical Description 14-1
14.2.1	Power Control Unit 14-1
14.2.2	Power Chassis Assembly 14-2
14.2.3	DC Regulator Module 14-3
14.2.4	DC Cable 14-5
14.2.5	AC Cable 14-5
14.3	Specifications 14-6

CHAPTER 15 POWER SUPPLY DETAILED DESCRIPTION

15.1	Introduction 15-1
15.2	AC Input Circuit 15-1
15.3	DC Regulator Module Operation 15-1
15.3.1	Generation of \pm Raw DC 15-5
15.3.2	LTC L Circuit 15-6
15.3.3	BUS AC LO L and BUS DC LO L Circuits 15-6
15.3.4	+15V Regulator Circuit 15-7
15.3.5	+5V Regulator Circuit 15-7
15.3.6	-15V Regulator Circuit 15-9

CHAPTER 16 POWER SUPPLY MAINTENANCE

16.1	Introduction 16-1
16.2	Adjustments 16-1
16.3	Circuit Waveforms 16-1
16.4	Troubleshooting 16-4
16.4.1	Troubleshooting Rules 16-4
16.4.2	Troubleshooting Hints 16-4
16.4.3	Troubleshooting Chart 16-4
16.5	Parts Identification 16-6

APPENDIX A INTEGRATED CIRCUIT DESCRIPTIONS

A.1	Introduction A-1
A.2	8266 2-Input, 4-Bit Digital Multiplexer A-3
A.3	7413 Dual NAND Schmitt Triggers A-4
A.4	7473 Dual J-K Master-Slave Flip-Flops A-5
A.5	7474 Dual D-Type Edge-Triggered Flip-Flops A-6
A.6	7475 4-Bit Bistable Latch A-7

CONTENTS (Cont)

		Page
A.7	7489 64-Bit Read/Write Memory	A-8
A.8	74121 Monostable Multivibrator	A-9
A.9	74150 Data Selector Multiplexer	A-10
A.10	74153 Dual 4-Line-to-1-Line Data Selectors/Multiplexers	A-12
A.11	74154 4-Line-to-16-Line Decoders/Demultiplexers	A-13
A.12	74157/74S158 Quadruple 2-Line-to-1-Line Multiplexer	A-14
A.13	74174 Hex/74175 Quad D-Type Flip-Flops with Clear	A-15
A.14	74181 Arithmetic Logic Unit/Function Generator (ALU)	A-16
A.15	74182 Look-Ahead Carry Generator	A-19
A.16	74193 Synchronous 4-Bit Up/Down Counter (Dual Clock with Clear)	A-21
A.17	74194 4-Bit Bidirectional Universal Shift Registers	A-23
A.18	7528 Dual Sense Amplifiers with Preamplifier Test Points	A-24
A.19	9602 Dual Retriggerable Monostable Multivibrator with Clear	A-25

APPENDIX B COMPUTER CONNECTORS

SUPPLEMENT 1 PDP-11/05, 11/10 10-1/2 INCH MOUNTING BOX AND POWER SYSTEM

SUPPLEMENT 2 DESCRIPTION OF DATA PATHS MODULE M7260 REVISION M

SUPPLEMENT 3 DESCRIPTION OF CONTROL LOGIC AND MICROPROGRAM MODULE M7261 REVISION R

ILLUSTRATIONS

Figure No.	Title	Page
1-1	Module Utilization Diagram for Configuration 1 (16K)	1-3
1-2	Module Utilization Diagram For Configuration 2 (8K)	1-3
1-3	Computer Backplane Connector and Pin Designations	1-4
1-4	Module Contact Designations	1-5
3-1	Computer Packaging	3-2
3-2	Computer Mounting Box	3-3
3-3	Computer Box With Top Cover Removed	3-3
3-4	Computer Box with Top and Side Covers Removed	3-4
3-5	Computer Chassis (showing peripheral cables and the Unibus)	3-4
3-6	Mounting Box Without Modules	3-5
3-7	Rear of Computer With Cable Strain Reliefs	3-5
3-8	Typical Cabinet Power Control System Wiring Diagram	3-8
4-1	Console Illustrating Switch Movements	4-1
4-2	Loading and Verifying the Bootstrap Loader	4-8
4-3	Loading Bootstrap Tapes Into Memory	4-9
4-4	Absolute Format	4-13
4-5	Bootstrap Format	4-14
5-1	KD11-B With Interconnections to Memory and Peripherals	5-2
5-2	KD11-B Processor Block Diagram	5-2
5-3	Instruction Interpreter Block Diagram	5-3
5-4	Typical Small Scale Integrated Circuit Representations	5-4
5-5	DPF LOAD IR L Signal	5-4
5-6	ALU, MSI Circuit Type 74181 Representation	5-5
5-7	E068 ROM Map Example	5-6
6-1	Addressing Mode Instruction Formats	6-2
6-2	PDP-11 Instruction Formats	6-18
7-1	Console Functional Block Diagram	7-2
7-2	Console Clock, Schematic and Timing Diagram	7-4
7-3	Counter, Simplified Logic Diagram	7-5

ILLUSTRATIONS (Cont)

Figure No.	Title	Page
7-4	Display Buffer and Driver, Simplified Logic Diagram	7-7
7-5	LED Driver Circuit	7-7
7-6	Control Switches and Bounce Buffers, Logic Diagram	7-8
8-1	1024-Bit and 256-Bit ROMs	8-1
8-2	32 X 8 ROM used as Generalized Gate	8-2
8-3	KD11-B Simplified Data Path Block Diagram	8-3
8-4	KD11-B Detailed Block Diagram	8-5
8-5	74181 Pin and Signal Designations	8-8
8-6	74182 Pin and Signal Designations	8-8
8-7	Arithmetic Logic Unit Block Diagram	8-9
8-8	B Register and Output Logic	8-12
8-9	B Register Shift Signal Inputs	8-15
8-10	Byte Format for Shifting Instructions	8-17
8-11	Block Diagram and Function Table for Scratch Pad Memory	8-18
8-12	Logic For Determining C and V Bits	8-25
8-13	Console Multiplexer Block Diagram	8-27
8-14	Processor Clock Timing Diagram	8-32
8-15	DATI and DATO Timing	8-34
8-16	Unibus Address Decoding	8-38
8-17	Bus Request (BR) Timing	8-39
8-18	Double-Buffering Data Flow	8-42
8-19	BUS AC LO and BUS DC LO Timing Diagram	8-45
9-1	Control Store Word Bit and Field Format	9-2
9-2	KD11-B Simplified Flow Diagram	9-10
9-3	Excerpt from Microprogram Flow (K-NL-KD11-B-1)	9-11
9-4	CMP #15, CHAR (022767), Simplified Flow Diagram	9-13
9-5	Excerpt of (K-WL-KD11-B-2) Microprogram Symbolic Listing	9-21
9-6	Excerpt of Microprogram Binary Listing (K-W-KD11-B-3)	9-22
9-7	Generation of SPM Enabling Signals	9-24
10-1	KM11 Maintenance Module, KD11-B Overlays	10-7
11-1	Component Side of G110 Control Module	11-2
11-2	Component Side of G231 Driver Module	11-2
11-3	Component Side of 8K H214 Stack Module	11-3
11-4	MM11-K, L Memory Block Diagram	11-5
12-1	Three-Wire Memory Configuration	12-2
12-2	Hysteresis Loop for Core	12-3
12-3	Three-Wire 3D Memory, Four Mats Shown for a 16-Word 4-Bit Memory	12-5
12-4	Device and Word Address Selection Logic, Block Diagram	12-6
12-5	Memory Organization for 8K Words	12-7
12-6	Address Assignments For Three Banks of 8K Words Each	12-8
12-7	Jumper Configuration For A Specific Memory Address	12-10
12-8	Device Decoding Guide	12-10
12-9	Type 8251 Decoder, Pin Designation and Truth Table	12-13
12-10	Decoding of Read/Write Switches and Drivers Y4-Y7	12-14
12-11	Switch or Driver Base Drive Circuit	12-15
12-12	Y-Line Selection Stack Diode Matrix	12-16
12-13	Typical Y-Line Read/Write Switches and Drivers	12-17
12-14	Interconnection of Unibus, Data Register, Sense Amplifier, and Inhibit Driver	12-20

ILLUSTRATIONS (Cont)

Figure No.	Title	Page
12-15	Y-Current Generator and Reference Voltage Supply	12-21
12-16	Sense Amplifier and Inhibit Driver	12-23
12-17	Type 7528 Dual Sense Amplifiers With Preamplifier Test Points	12-24
12-18	Stack Discharge Circuit	12-25
12-19	DC LO Circuit, Schematic Diagram	12-26
12-20	Basic Timing and Control Signal Functions	12-29
12-21	TWID H and TNAR H Control Logic	12-31
12-22	Generation of MSEL RESET L	12-32
12-23	Slave Sync (SSYN) Circuit	12-35
12-24	Pause/Write Restart Circuit	12-37
12-25	Strobe Generating Circuit and Timing Diagram for STROBE H	12-38
12-26	Flow Chart For Memory Operation	12-40
13-1	Strobe Pulse Waveform	13-2
13-2	Troubleshooting Chart	13-3
13-3	MM11-K Sense/Inhibit Waveforms	13-5
13-4	Drive Waveforms	13-7
14-1	Power Chassis Assembly (with DC Regulator Module)	14-2
14-2	Power Supply Assembly (with DC Regulator Module Removed)	14-3
14-3	DC Regulator Module (Top View)	14-4
14-4	DC Regulator Module (Bottom View In Mounting Box)	14-4
15-1	Detailed AC Interconnection Diagram	15-2
15-2	115V Connections – Simplified Schematic Diagram	15-3
15-3	230V Connection Diagram	15-3
15-4	Regulator Module Block Diagram	15-4
15-5	Rectifier and LTC L Circuits	15-5
15-6	BUS AC LO and BUS DC LO Circuits	15-6
15-7	+15V Regulator Circuit	15-7
15-8	+5V Regulator Circuit	15-8
15-9	-15V Regulator Circuit	15-9
16-1	+5V Regulator Circuit Waveforms	16-2
16-2	-15V Regulator Circuit Waveforms	16-3

TABLES

Table No.	Title	Page
4-1	Significance of ADDRESS/DATA Indicators	4-3
4-2	Bootstrap Loader Instructions	4-6
4-3	Memory Bank Assignments	4-6
6-1	Addressing Modes	6-3
6-2	Addressing Times	6-4
6-3	Single Operand Instructions	6-5
6-4	Double Operand Instructions	6-9
6-5	Program Control Instructions	6-12
6-6	Operate Group Instructions	6-17
6-7	Condition Code Operators	6-18
6-8	PDP-11 Differences	6-19
7-1	Scan Address Signal Generation	7-3
7-2	Counter States	7-6

TABLES (Cont)

Table No.	Title	Page
8-1	ALU Control Signals	8-10
8-2	Control Store Signals for BLEG Operations	8-13
8-3	Register Utilization in SPM	8-17
8-4	SPM Address Line Signals	8-19
8-5	SPAM Input Data Sources	8-19
8-6	Processor Status Word Bit Assignments	8-20
8-7	Effect of E066 Outputs DPG CMP+BIT L, DPG MOVE L, and DPG BYTE L	8-29
8-8	Auxiliary Control for Binary and Unary Instructions	8-31
8-9	Unibus Addresses	8-38
8-10	Trap Priorities	8-40
9-1	KD11-B Control Store Fields	9-2
9-2	Microprogram Branches (BUT)	9-7
9-3	Flow Notation Glossary	9-12
10-1	Test Equipment and Tools	10-2
10-2	Baud Rate Adjustment	10-4
10-3	Engineering Drawing Print List and Functions	10-4
10-4	KM-1 and KM-2 Overlay Designations	10-8
11-1	MM11-K and L Memory Specifications	11-3
12-1	Addressing Functions	12-4
12-2	Enabling Signals for Word Register Gating	12-12
12-3	Word Address Decoding Signals	12-18
12-4	Selection of Bus Transactions	12-27
12-5	Generation of Memory Operating Signals	12-28
14-1	Power Supply Input Specifications	14-6
14-2	Power Supply Output Specifications	14-7
14-3	Mechanical and Environmental Specifications	14-10
16-1	Troubleshooting Chart	16-5
A-1	Integrated Circuits	A-1
B-1	Connectors	B-1

FOREWORD

This manual describes the PDP-11/05 and PDP-11/10 Computers. The PDP-11/05 and PDP-11/10 are electrically identical. The PDP-11/05 is specified for the Original Equipment Manufacturer (OEM) market and the PDP-11/10 is specified for the end user market.

The PDP-11/05 is available in two versions: one provides a maximum of 8K words of core memory and the other provides a maximum of 16K words of core memory. The PDP-11/10 is available only with a maximum of 8K words of core memory.

This manual is divided into four parts.

Part 1	Computer Description
Part 2	KD11-B Processor
Part 3	MM11-K, MM11-L Memories
Part 4	Power Supply

Chapter outlines of each part are shown below.

Part 1 COMPUTER DESCRIPTION

Chapter 1	Computer Components
Chapter 2	Unibus
Chapter 3	Unpacking and Installation
Chapter 4	Operation

Part 2 KD11-B PROCESSOR

Chapter 5	Processor General Description
Chapter 6	Instruction Set
Chapter 7	Console Description
Chapter 8	KD11-B Detailed Description
Chapter 9	Microprogram Control
Chapter 10	KD11-B and Console Maintenance

Part 3 MM11-K and MM11-L MEMORIES

Chapter 11	MM11-K and L General Description
Chapter 12	MM11-K and L Detailed Description
Chapter 13	Memory Maintenance

Part 4 POWER SUPPLY

Chapter 14	Power Supply General Description
Chapter 15	Power Supply Detailed Description
Chapter 16	Power Supply Maintenance

A bound volume of engineering drawings is supplied with each computer.

The following related documents are valuable as references.

PDP-11/05, 11/10 Processor Handbook
PDP-11 Peripherals and Interfacing Handbook
PDP-11 Paper-Tape Software Programming Handbook
(Document No. DEC-11-GGPB-D)

PART 1

COMPUTER DESCRIPTION

Part 1 provides a general physical description of the PDP-11/05 and PDP-11/10 computers. Unibus operation is discussed prior to the discussions of computer installation and operation. The chapters of Part 1 are:

- Chapter 1 – Computer Components
- Chapter 2 – Unibus
- Chapter 3 – Unpacking and Installation
- Chapter 4 – Operation

CHAPTER 1

COMPUTER COMPONENTS

1.1 INTRODUCTION

This chapter briefly describes the major components of the PDP-11/05, 11/10 Computer. It includes module utilization diagrams for both computer configurations and a backplane connector and pin designation diagram.

1.2 COMPUTER COMPONENTS

The computer consists of a mounting box, console, processor, core memory, prewired backplane, power supply, fans, and interconnecting cables. The processor is contained on two modules, and each 4K or 8K memory is contained on three modules.

1.2.1 KD11-B Processor

The processor comprises the M7260 Data Path Module and the M7261 Control Logic and Microprogram Module. They are hex height modules which measure 8-1/2 inches long by 15 inches high. A hex height module contains six edge connectors (A-F).

All the processor functional components are contained on these modules. The M7260 Data Path Module contains: data path logic, processor status word logic, auxiliary arithmetic logic unit control, instruction register and decoding logic, and serial communications line interface. The M7261 Control Logic and Microprogram Module contains: internal address detecting logic, stack control logic, Unibus control logic, priority arbitration logic, Unibus drivers and receivers, microbranch logic, microprogram counter, control store logic, power fail logic, line clock, and processor clock.

The serial communications line (SCL) interface is directly connected to the desired serial communications device. It can operate at speeds of 110–300 baud and is program compatible with the KL11 Teletype Control Interface option. The SCL is compatible with the LA30 DECwriter at 30 characters per second, the VT05 Alphanumeric CRT Display Terminal at 30 characters per second, and the Teletype Model 33 ASR at 10 characters per second.

The line time clock (LTC) allows the program to measure time by sensing the 50 Hz or 60 Hz ac line frequency. This clock is program compatible with the KW11-L Line Time Clock option.

The line time clock and the serial communications line interface are not connected to the Unibus; they use an internal bus and can be addressed only by the processor and the console.

1.2.2 Core Memory

The PDP-11/05 is available in two versions: one provides a maximum of 8K words of core memory and the other provides a maximum of 16K words. The PDP-11/10 is available only with a maximum of 8K words of core memory. A separate add-on core memory system (ME11-L) is available to provide an additional 8K, 16K, or 24K words of core memory. A PDP-11/05 or PDP-11/10 processor provides program control for a maximum of 32K words of memory; therefore, the self-contained memory plus the ME11-L must not be greater than 32K words.

Configuration 1 is the 16K version (Figure 1-1). Unibus M930 Terminator Modules are installed in slots A2-B2 and A5-B5. If other peripherals are to be connected to the computer, the terminator module in slot A2-B2 must be replaced with a BC11A Unibus cable, and a terminator module must be installed in the last device in the system. Slot C1-F1 provides the only space for a small peripheral controller. If this slot is not used, A G727 Grant Continuity Module must be installed in slot D1. If a small peripheral controller is to be installed, the G727 module must be removed first. Slots A1 and B1 are wired for the KM11 Maintenance Module. The core memories (3 modules each) are physically interchangeable as systems.

Configuration 2 is the 8K version (Figure 1-2). Unibus M930 Terminator Modules are installed in slots A3-B3 and A5-B5. If required, a BC11A Unibus cable can be installed in place of the terminator in slot A3-B3. Slots C1-F1 C2-F2, C3-F3, and C4-F4 can be used for small peripheral controllers. Slot A1-B1 is wired for a DF11 Communications Line Adapter that provides signal conditioning for communications devices using signals that are not TTL compatible. Slots A2 and B2 are wired for the KM11 Maintenance Module.

Figure 1-3 shows the backplane connector block configuration as viewed from the wirewrap pin side. The pin arrangement for each connector block is identical. It represents the total pins (36) available on the double-sided edge connector of a single height module. Connector A1 is shown in detail. Module contact designations are shown in Figure 1-4.

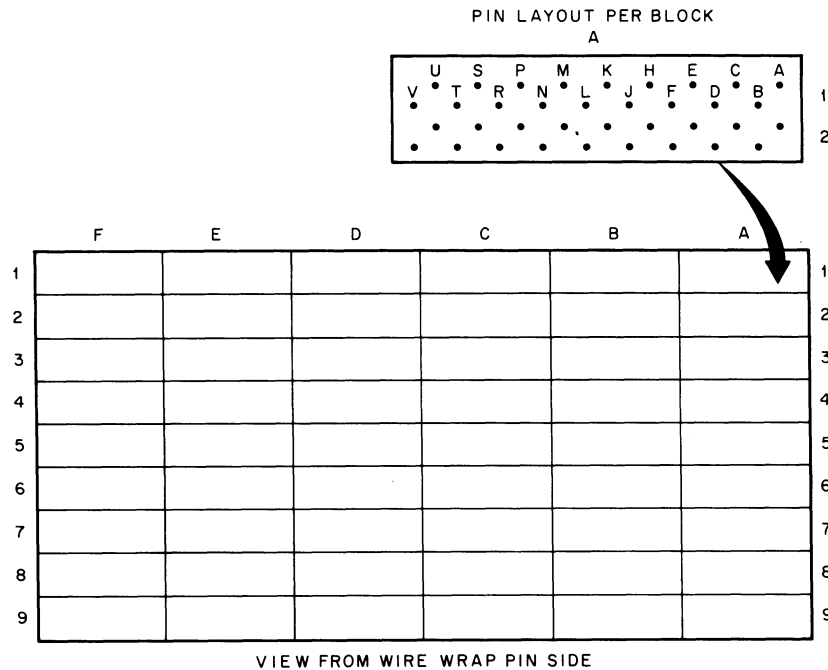

11-1220

Figure 1-3 Computer Backplane Connector and Pin Designations

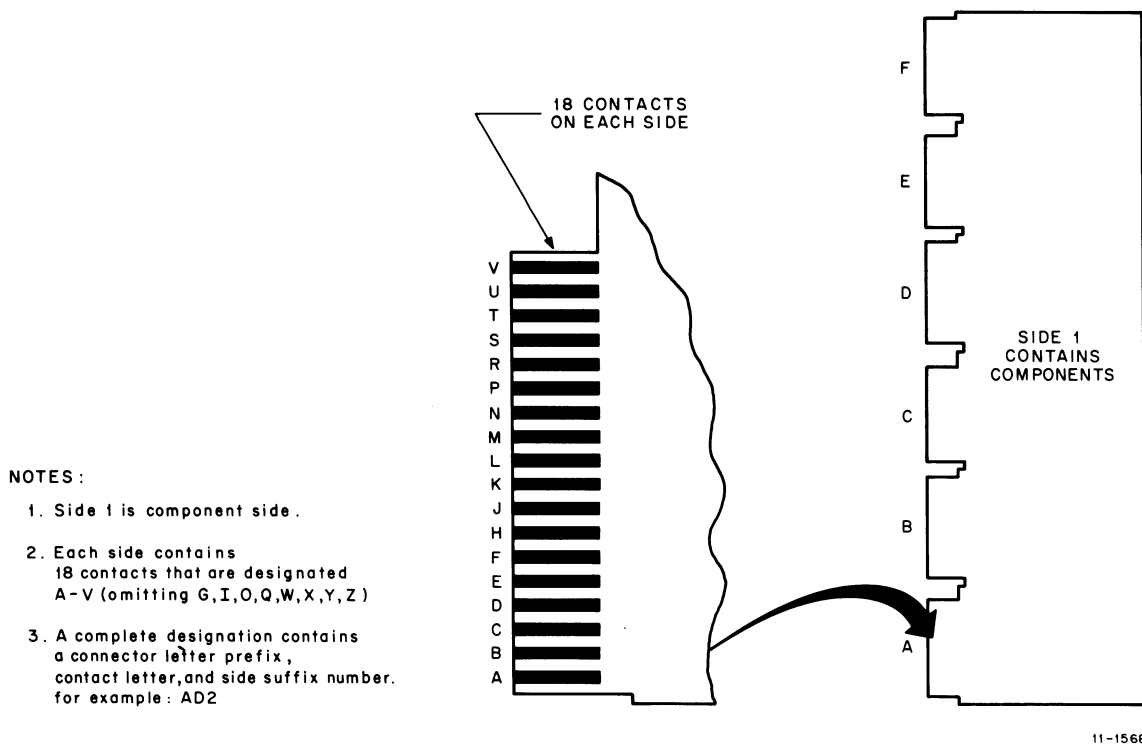

Figure 1-4 Module Contact Designations

1.3 ME11-L CORE MEMORY SYSTEM

Additional core memory is available for the computer in the self-contained add-on ME11-L Core Memory System. The basic ME11-L consists of an 8K MM11-L memory and power supply installed in a mounting box. It is expandable to 16K words or 24K words maximum by adding one or two more MM11-L memories. The ME11-L uses the same backplane construction as the computer. Nine slots are provided and they are wired to accommodate three MM11-L memories. These core memories (3 modules each) are physically interchangeable as systems and as individual modules within a system for troubleshooting purposes. If only one memory is used, the modules must be installed in the three bottom slots (7, 8, and 9).

1.4 EXTENSION MOUNTING BOX

Additional interface logic for the computer is installed in an extension mounting box identical to those used for the rest of the PDP-11 family. A rack-mounted box (BA11-ES) or a tabletop box (BA11-EC) can be used. The mounting box contains cooling fans, filter, and power cord. Space is provided to install six system units and an H720 Power Supply. Details of the extension mounting box, system units, and H720 Power Supply are included in the *PDP-11 Peripherals and Interfacing Handbook*.

CHAPTER 2

UNIBUS

2.1 INTRODUCTION

This chapter describes in general the operation of the Unibus.

The following documents, in conjunction with this manual, will aid the reader in understanding interface techniques and the overall PDP-11 system.

- a. PDP-11/05, 11/10 Processor Handbook
- b. PDP-11 Peripherals and Interfacing Handbook
- c. Digital Logic Handbook

All communication between PDP-11 system components is through the high-speed Unibus. The Unibus operational concepts are vital to the understanding of the hardware and software implications of the Unibus.

2.2 UNIBUS STRUCTURE

The Unibus is a single common path that connects the processor, memory, and all peripherals. Addresses, data, and control information are transmitted along the 56 lines of the bus.

Every device on the Unibus employs the same form of communication; thus, the processor uses the same set of signals to communicate with memory and with peripheral devices. Peripheral devices also communicate with the processor, memory, or other peripheral devices via the same set of signals.

All instructions applied to data in memory can be applied equally well to data in peripheral device registers, enabling peripheral device registers to be manipulated by the processor with the same flexibility as memory. This feature is especially powerful, considering the capability of PDP-11 instructions to process data in any memory location as though it were an accumulator.

2.2.1 Bidirectional Lines

Most Unibus lines are bidirectional, allowing input lines to also be driven as output lines. This is significant in that a peripheral device register can be either read or used for transfer operations. Thus, the same register can be used for both input and output functions.

2.2.2 Master/Slave Relationship

Communication between two devices on the bus is based on a master/slave relationship. During any bus operation, one device, referred to as the bus master, has control of the bus when communicating with another device, the slave. A typical example of this relationship is the processor (master) transferring data to memory (slave). Master/slave relationships are dynamic. The processor, for example, passes bus control to a disk; the disk, as master, then communicates with a slave memory.

The Unibus is used by the processor and all I/O devices; thus, a priority structure determines which device gains control of the bus. Consequently, every device on the Unibus capable of becoming bus master has an assigned priority. When two devices capable of becoming bus master have identical priority values and simultaneously request use of the bus, the device that is electrically closest to the bus receives control.

2.2.3 Interlocked Communication

Communication on the Unibus is interlocked between devices. Each control signal issued by the master device must be acknowledged by a response from the slave to complete the transfer. Consequently, communication is independent of the physical bus length and the response time of the master and slave devices. The maximum transfer rate on the Unibus, with optimum device design, is one 16-bit word every 400 ns or 2.5 million 16-bit words per second.

2.3 PERIPHERAL DEVICE ORGANIZATION AND CONTROL

Peripheral device registers are assigned addresses similar to memory; thus, all PDP-11 instructions that address memory locations can become I/O instructions, enabling data registers in peripheral devices to take advantage of all the arithmetic power of the processor.

The PDP-11 controls devices differently than most computer systems. Control functions are assigned to a register address, and then the individual bits within that register can cause control operations to occur. For example, the command to make the paper-tape reader read a frame of tape is provided by setting a bit (the reader enable bit) in the control register of the device. Instructions such as MOV and BIS may be used for this purpose. Status conditions are also handled by the assignment of bits within this register, and the status is checked with TST, BIT, and CMP instructions.

2.4 UNIBUS CONTROL ARBITRATION

The Unibus is capable of performing two basic and parallel tasks in order to allow transfers by multiple peripherals at maximum speed. The first is the actual transfer of data between the current bus master and its addressed slave. The second is the selection of the next bus master, the peripheral which will be allowed to assert control as soon as the bus becomes free. It is important to note that the granting of future mastership is in no way influenced by either the current master or its method of obtaining the bus. It is this fact which allows these functions to be performed in parallel and allows transfers on the bus at a maximum rate.

2.4.1 Priority Transfer Requests

To gain mastership of the Unibus, a peripheral must first make a request to the processor for the bus and then wait for its selection. The processor contains the logic necessary to arbitrate these requests because normally there are several requests pending at any given time.

There are two classes of requests: bus requests and non-processor requests. A bus request (BR) is simply a request by a peripheral to obtain control of the Unibus with the understanding by the processor that the peripheral may end its use of the bus with a processor interrupt. An interrupt is a command to the processor to begin executing a new routine pointed to by a location selected by a device. A non-processor request (NPR) is similarly a request for the bus, but with the exception that it may not interrupt the processor. Since the granting of an NPR cannot affect the execution of the processor, it can occur during or between instructions. BRs however, by possibly causing execution to be diverted to a totally new routine, can only be granted between instructions. In this way, NPRs are assigned priority over any BR.

Between bus requests, there are four levels of priority created by four separate request lines. They are assigned priority levels 4 through 7; BR4 is the lowest and BR7 is the highest. These levels are associated with the program controlled priority level of the processor controlled by bits 7, 6, and 5 of the processor status register. Only BRs on a priority level higher than the level of the processor are eligible for receiving a bus grant. Thus, during high priority program tasks, all or selected Unibus requests (hence interrupts) can be inhibited by raising the level of the processor priority.

Another form of priority arbitration occurs through the system configuration. When the processor grants a request, the grant travels along the bus until it reaches the first requesting device which terminates the grant. Therefore, along the same grant line, the device electrically nearest the processor has the highest priority. Also note that in the KD11-B, the internal line clock is logically the last device on BR6, and the serial communication line interface is logically the last device on BR4.

After a requesting device receives a bus grant it asserts its selection as next bus master until the bus is free, thus inhibiting other requests from being granted. When the bus becomes free, the selected device asserts control of the bus and relinquishes its selection as next bus master so that the priority arbitration among pending requests may continue.

2.4.2 Processor Interrupts

After gaining control of the bus through a BR, a device can perform one or more transfers on the bus and/or request a processor interrupt. This is typically requested after a device has completed a given task; e.g., typing a character or completing a block data transfer through NPRs. If a peripheral wishes to interrupt the processor, it must assert the interrupt after gaining control of the bus but before relinquishing its selection as next bus master. Thus the processor knows that it may not fetch the next instruction, but must wait for the interrupt to be completed. Along with asserting the interrupt, the device asserts the unique memory address, known as the interrupt vector address, containing the starting address of the device service routine. Address vector +2 contains the new processor status word (PSW) to be used by the processor when beginning the service routine. After recognizing the interrupt, the processor reads the vector address and saves it in an internal register. It then pushes the current PSW and program counter onto the stack and loads the new program counter (PC) and PSW from the vector address specified. The service routine is then executed.

NOTE

These operations are performed automatically and no device polling is required to determine which routine to execute.

The device service routine can cause the processor to resume the interrupted process by executing the return from interrupt (RTI) instruction which pops the top two words from the processor stack and transfers them back to the PC and PS registers.

2.4.3 Data Transfers

After asserting control of the Unibus, the device does not release control until it has completed either one or more data transfers or an interrupt. Typically, only one transfer is completed each time the device gains control of the bus because few single devices can give or receive information at the maximum Unibus rate. Holding the bus for multiple transfers inhibits other devices from using the bus.

A transfer is initiated by the master device asserting a slave address and control signals on the bus and a master or address validity signal. The appropriate slave recognizes the valid address, reads or writes the data, and responds with a transfer complete signal. The master recognizes the transfer complete, sends or accepts data, and drops the address validating signal. It can then assert a new address and repeat the process or release control of the bus completely.

The importance of this type of structure is that it enables direct device-to-device transfers without any interaction from the central processor. An NPR device, such as a high speed CRT display, can gain fast access to the bus and transfer data at high rates while refreshing itself from memory without slowing down the processor.

CHAPTER 3

UNPACKING AND INSTALLATION

3.1 INTRODUCTION

The computer is shipped ready to operate in either a protective box or a 19-inch cabinet. Unless required by peripherals, there are no special shipping mounts internal to the computer. Prior to final electrical testing, each computer is thermal cycled, vibrated, and subjected to mechanical shock with all modules in place.

Basic computers are shipped in the package illustrated in Figure 3-1. Sufficient hardware is included in the shipping carton to rack mount the computer.

3.2 UNPACKING

Remove the computer from the box and remove the protective plastic cover from the console. Slide mounts are attached to the computer, but mounting screws are packed in a bag located in the same box. Also included is one 83600 Serial Communication Line (SCL) cable and two keys for the console lock. The 83600 SCL cable has a Berg 127009-0, 40-pin connector on one end that matches the SCL output connector on the computer. The other end of the 83600 SCL cable terminates in a Mate-N-Lok 1209340 which matches that used on the VT05, LA30, and Model 33 ASR Teletype[®].

If the computer was ordered as a system with options requiring small peripheral controllers, the controllers may be inside the computer box. Small peripheral controllers are used to interface options such as a line printer or paper-tape reader/punch, as well as to implement a device such as a programmable clock.

After removing the computer from its package, it should be inspected for damage. It is advisable to save the packing carton in case it is necessary to return the unit for service.

A computer shipped in a 19-inch cabinet is locked in place by a metal lock attached to the rear of each slide assembly. Each lock is J-shaped and is attached by an 8-32 screw that passes through the slot in the chassis section of the slide and is threaded into the longer leg of the lock. The shorter leg is hooked around the end of the cabinet section of the slide to prevent extension of the slide. Both locks must be removed in order to slide the computer out of the cabinet. Retain the locks and screws for re-use if the equipment is to be shipped or moved any distance.

3.3 MECHANICAL DESCRIPTION

Figure 3-2 illustrates the 5-1/4 by 19 by 20 inch computer mounting box, including rack-mountable slide and console. The removable top cover of the mounting box is fastened by four Cam-Lock screws. The removable side panel is fastened by four Phillips-head screws.

Figure 3-3 shows the mounting box with the top cover removed. The backplane unit divides the power supply from the module side of the mounting box. The internal SCL cable runs from the backplane under the power supply unit to the rear of the mounting box.

[®]Teletype is a registered trademark of the Teletype Corporation.

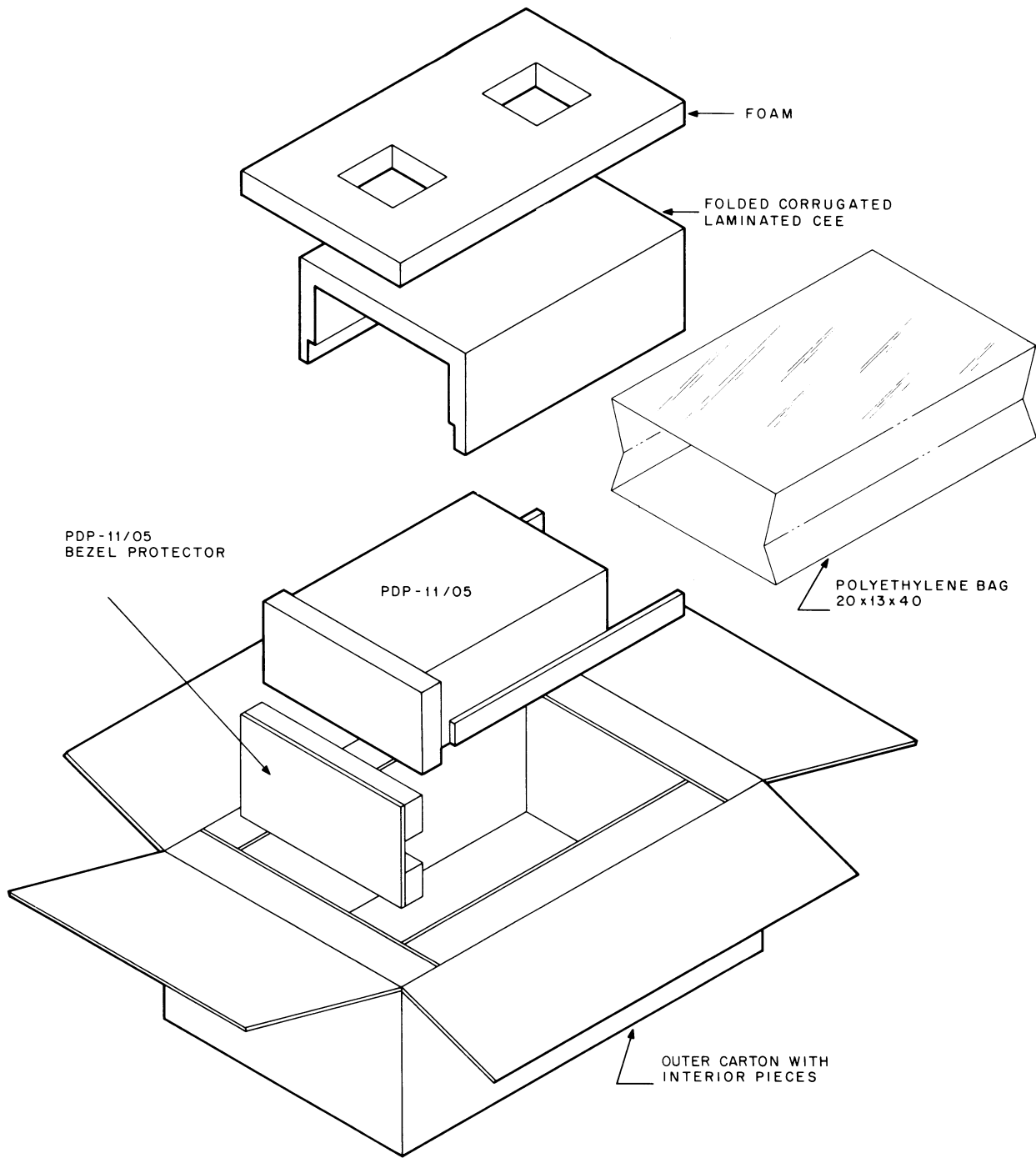

11-1223

Figure 3-1 Computer Packaging

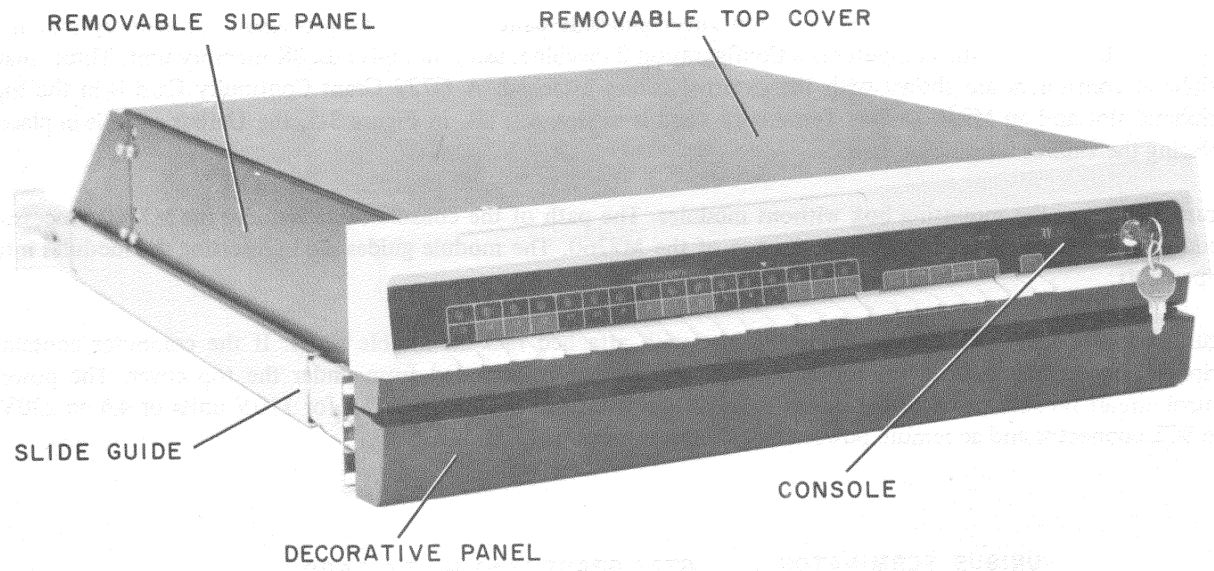

Figure 3-2 Computer Mounting Box

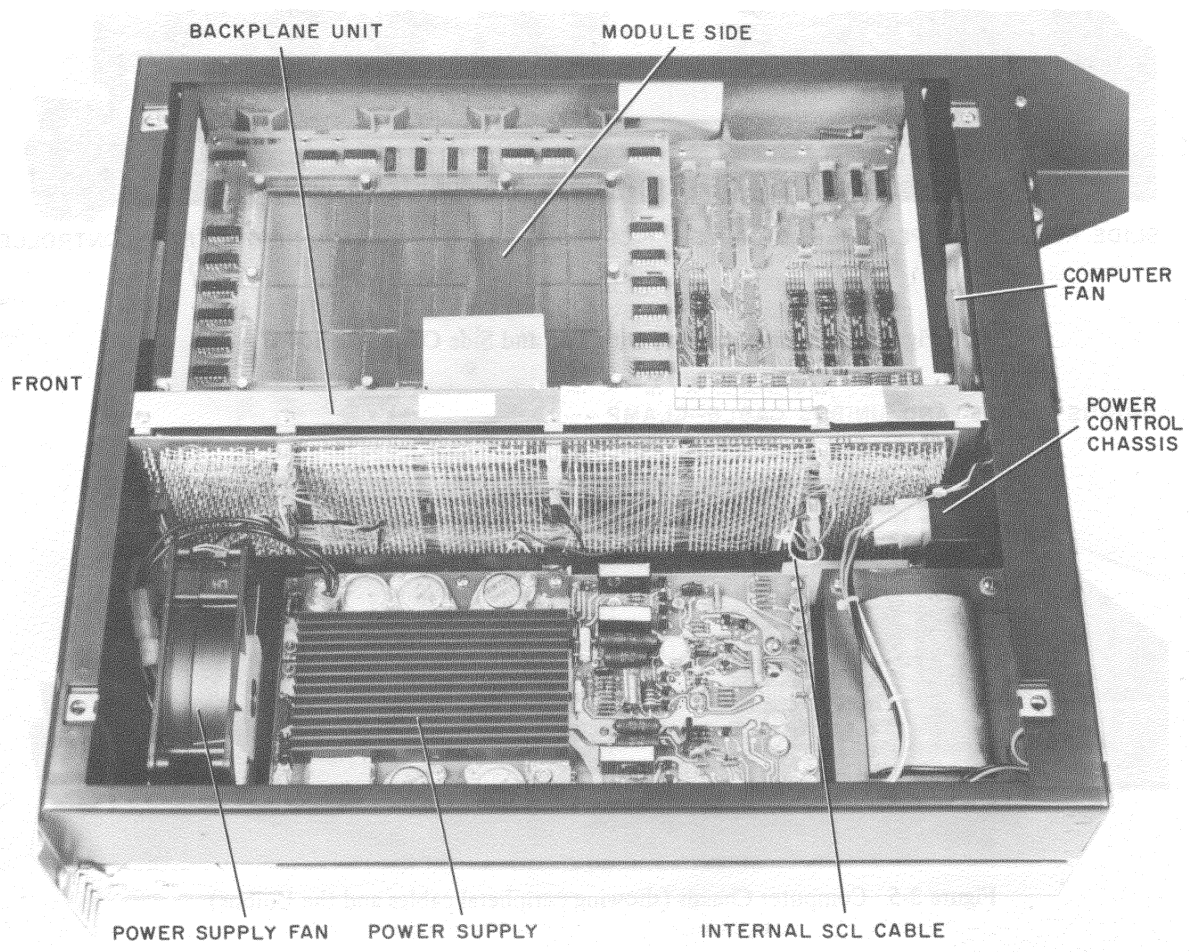

Figure 3-3 Computer Box With Top Cover Removed

Figure 3-4 shows the mounting box with top cover and side panel off, and the processor and memory modules plugged in. In this case, the computer is a Configuration 2 machine, using an MM11-L, 8K memory unit. Three small peripheral controllers are shown with the external cables attached. A G727 Grant Continuity Card is in the top peripheral slot and an M930 Unibus Terminator Card is in slot A3, B3. In Figure 3-5, the Unibus cable is in place, replacing the Unibus terminator card.

Figure 3-6 shows the mounting box without modules. The path of the console cable is under the M7260 Processor Module, then up and over to plug into the top of the M7260. The module guides aid in inserting the modules into proper slots.

Figure 3-7 is a rear view of the mounting box with attached rack-mountable slides. If the computer contains peripheral controllers outside the mounting box, the Unibus is extended from under the top cover. The power control circuit breaker protects the power supply from overload. It is rated at 7A for 110V units or 4A on 230V. The SCL connector and ac remote power control connectors are also shown.

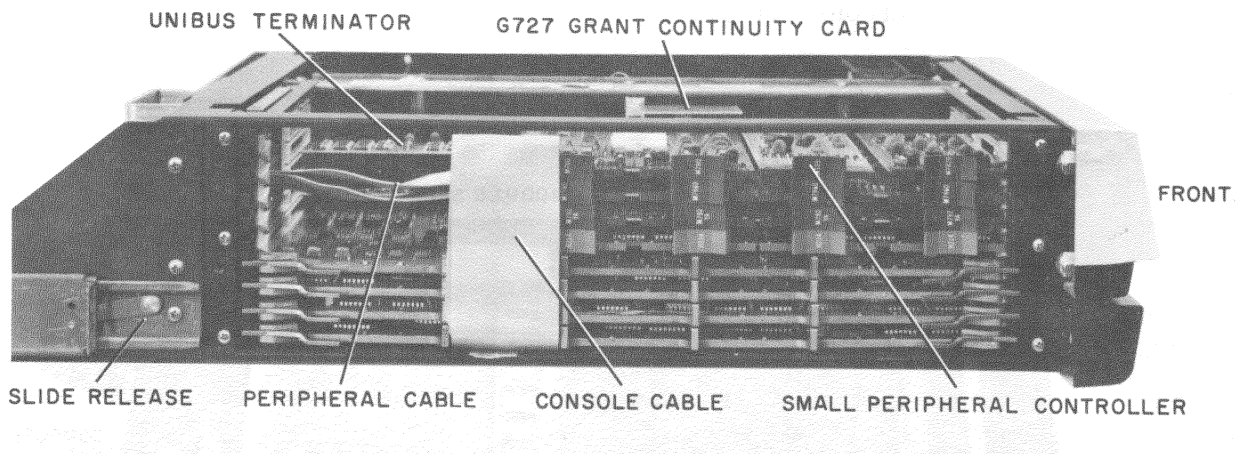

Figure 3-4 Computer Box with Top and Side Covers Removed

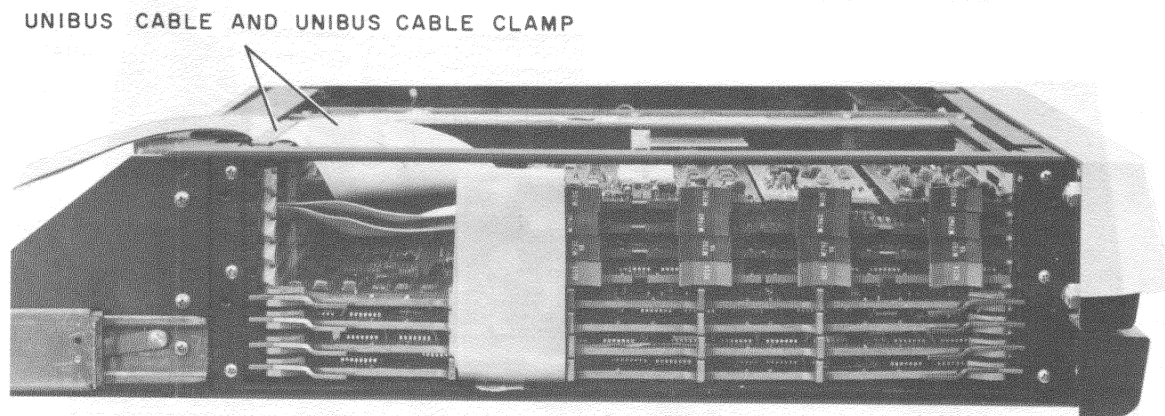

Figure 3-5 Computer Chassis (showing peripheral cables and the Unibus)

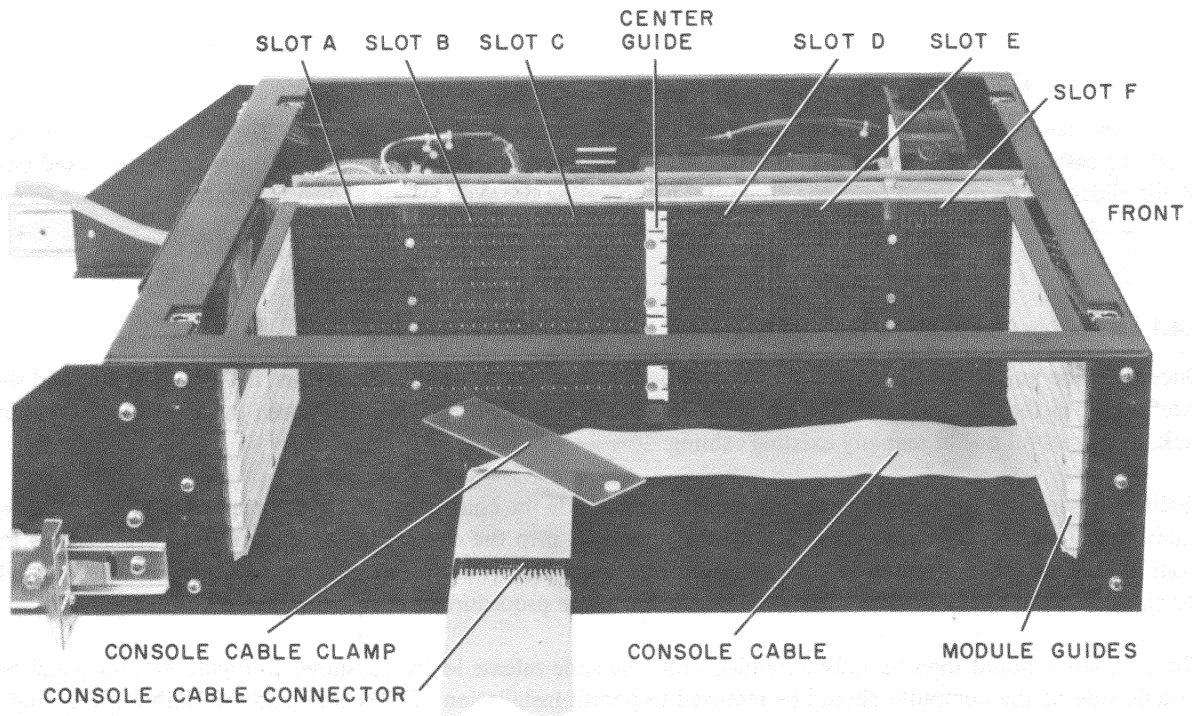

Figure 3-6 Mounting Box Without Modules

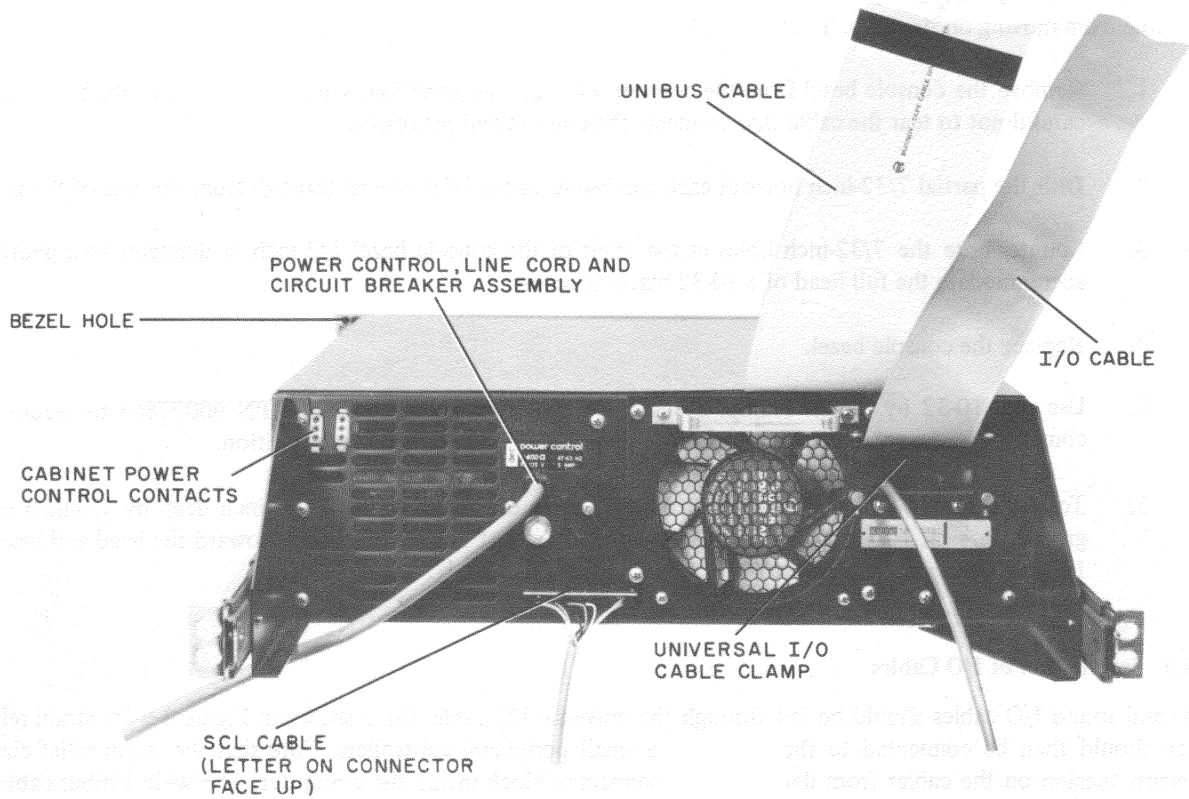

Figure 3-7 Rear of Computer With Cable Strain Reliefs

3.4 INSTALLATION

The computer mounts in a standard 19-inch wide by 25-inch deep equipment bay. The computer is mounted on slides for easy service. To mount the unit, first attach the fixed portion of the slides to the cabinet; the fixed portion of the slides can be removed from the computer by actuating the slide release shown in Figure 3-4. Be sure to mount the slides so that the fixed guides are parallel and level with the ground.

3.4.1 Mounting Computer on Installed Slides

Once the slide guides have been securely fastened in the cabinet using all eight screws, lift the computer and slide it carefully onto the slide guides until the slide release locks. Lift the slide release and push the computer fully into the rack, being careful not to tear any existing cabling.

Slightly loosen all eight cabinet slide mounting screws. Slide the computer back and forth several times to allow the slides to assume an optimum position. Push the computer into the cabinet as far as possible, leaving access to the front mounting screws. Tighten all eight cabinet slide mounting screws. Slide the computer back and forth and check for binding of the slides. If there is binding, repeat the above procedure until it is eliminated.

The computer should then be fully extended until the slide release locks. As shown in Figure 3-4, the panel on the module side of the computer should be removed to permit installation of I/O cables and the Unibus if required. The panel is removed by loosening and removing four Phillips-head screws.

3.4.2 Securing Computer to Cabinet Rack

If the rack-mounted computer is used in a moving environment, it must be secured to the cabinet rack to prevent the machine from moving on its slides. This option, if desired, is implemented as follows:

1. Remove the console bezel from the computer by removing the four screws at the rear of the bezel, being careful not to tear the cable that connects the console and processor.
2. Drill the partial 7/32-inch holes at each top inside corner of the bezel through from the rear of the bezel.
3. Counter-bore the 7/32-inch holes at the front of the console bezel 1/2 inch in diameter to a depth to accommodate the full head of a 10-32 machine screw.
4. Replace the console bezel.
5. Use two 10-32 by 2-inch Phillips-head screws and two Tinnerman nuts (PN 9007786) to secure the computer to the cabinet rack through the bezel holes at the desired rack position.
6. To make the 10-32 by 2-inch Phillips-head screws captive, machine a 1/8-inch deep by 1/8-inch wide groove, in each 10-32 by 2-inch Phillips-head screw just above the threads toward the head and insert a 1/8 I.D. O-ring in each groove.

3.4.3 Installation of I/O Cables

Flat and round I/O cables should be fed through the universal I/O cable clamp shown in Figure 3-6 for strain relief. They should then be connected to the appropriate small peripheral controllers. Note that the strain relief clamp prevents tension on the cables from damaging the connector block inside the computer. The wide Unibus cable, if required, should be folded as shown in Figure 3-5 and routed over and through a clamp attached to the top of the fan as shown in Figure 3-7. Note that there is a guide extending from the fan that prevents the Unibus cable from blocking air flow to the computer.

As shown in Figure 3-4, systems in which the Unibus is terminated in the computer box must have an M930 Terminator Card in slot A3-B3 as well as in slot A5-B5.

3.5 INTERCHANGEABLE PERIPHERAL SLOTS

The four peripheral slots in Configuration 2 are identical; therefore, it is possible to arrange the small peripheral controllers for the best mechanical convenience. For example, to diagnose a failure in a small peripheral controller, it may be convenient to place the selected option in the top slot where its components will be exposed.

3.6 SIDE AND TOP COVER INSTALLATION

Figures 3-4 and 3-5 show the computer ready for installation of the side cover. Note that the console cable is folded into a flat loop in order to clear the side cover. Attached to the side cover is the continuation of the left-hand slide. All four 8-32 screws that hold the cover in place should be inserted and tightened securely. The top cover can now be installed using the four Cam-Lock screws.

3.7 AC POWER SUPPLY CONNECTION

Computers designed for use on 115-Vac circuits are equipped with a 3-prong connector, which, when inserted into a properly wired 115-Vac outlet, grounds the case of the computer. It is unsafe to operate the computer unless the case is grounded since normal leakage current from the power supply flows into metal parts of the chassis.

If the integrity of the ground circuit is questionable, the user is advised to measure the potential between the computer case and a known ground with an ac voltmeter.

3.7.1 Connecting to Voltages Other than 115V

The computer will operate at voltages ranging from 95V to 135V and from 190V to 270V (47 Hz – 63 Hz), providing the proper power control is attached to the computer. The computer is ordered for nominal voltages of 115V or 230V. The standard 3-prong connector for 115V is identical to that found on most household appliances. A standard 3-prong connector is also used for 230V.

On installations outside of the United States or where the National Electrical Code does not govern building wiring, the user is advised to proceed with caution.

3.7.2 Quality of AC Power Source

Computer systems consisting of CPU, memory, and peripherals are often sensitive to the interference present on some ac power lines. If a computer system is to be installed in an electrically “noisy” environment, it may be necessary to condition the ac power line. DEC Field Service Engineers can assist customers in determining if their ac line is satisfactory.

3.8 CABINET POWER CONTROL

Provisions have been made for the computer switch to operate a cabinet power control. This feature permits the computer key lock switch to control the power supply for peripherals attached to the computer (Part 4). The power control contacts are closed when the key lock switch is in the POWER or PANEL LOCK positions. The wiring diagram for a typical cabinet power control system is shown in Figure 3-8. The power control contacts of the computer may be used to switch a maximum of 230V at 4A.

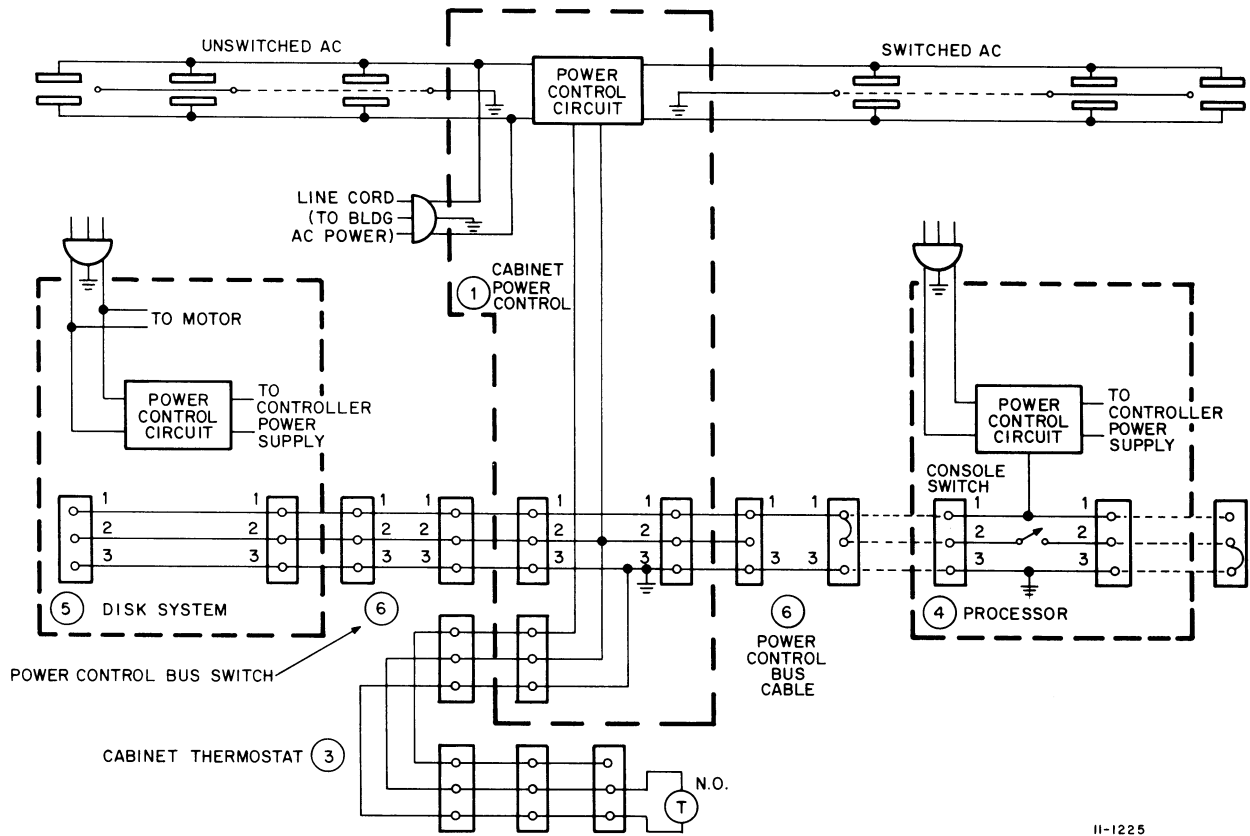

11-1225

Figure 3-8 Typical Cabinet Power Control System Wiring Diagram

3.9 INSTALLATION CERTIFICATION

Once the computer has been installed, it is strongly recommended that a system diagnostic be run to ensure that the equipment operates correctly and that installation has been properly performed. Because system configurations widely vary, no one diagnostic will completely exercise all the attached devices.

The *MAINDEC User's Manual* that comes with the diagnostic package should be consulted for the appropriate diagnostic to be run, depending upon the attached devices. The *MAINDEC User's Manual* lists the devices that each diagnostic will exercise. The three system exercisers presently available are T17 System Exerciser (MAINDEC-11-DZKAP) for relatively small systems, General Test Program (MAINDEC-11-DZQGA) for medium to large systems, and Communications Test Program (MAINDEC-11-DZQCA) for communications-oriented systems. At least one of the above diagnostics and, if appropriate, the other two, should be used to verify system operation.

Once the diagnostic is selected, the respective diagnostic write-up should be consulted for specific operating instructions. If the user is not familiar with console operation and/or procedures for loading paper tapes, he should read Chapter 4 of this manual.

3.10 WARRANTY SERVICE (Domestic Only)

If the machine is still covered under the 30 day return-to-factory warranty, and it is desired to return it for factory service, the following procedure should be used. If the machine is no longer on warranty, the local DEC Field Service office should be contacted.

1. Call the Maynard, Massachusetts Repair Depot, Telephone 617-897-5111, X4079 or X2135.
2. The caller will receive an RA (Return Authorization) number, which must appear on the shipping label of the package being returned.
3. Package the machine in an equivalent shipping container, similar to the one the computer arrived in. If possible, use the original computer shipping container.
4. Send the machine to the following address:

Digital Equipment Corporation
146 Main Street
Maynard, Massachusetts 01754
Att: Depot Repair, Bldg, 21-4

RA # XXXX

CHAPTER 4

COMPUTER OPERATION

4.1 INTRODUCTION

This chapter assumes that the computer is installed and connected to the ac power line. It is also assumed that the reader has access to the appropriate diagnostic materials, and a copy of the absolute loader paper tape. It is further assumed that the user is using paper tapes to load software and diagnostics. For systems that have mass storage services, i.e., disks or DECTape, the user should refer to the appropriate software manuals for mass storage operating systems.

4.2 POWER SWITCH OPERATION

The key lock power switch shown in Figure 4-1 has three positions:

- OFF – Fully counterclockwise
- POWER – 90° clockwise from OFF
- PANEL LOCK – 180° clockwise from OFF

In the OFF position, ac power is removed from the primary of the computer power supply, and the cabinet power control contacts are open-circuited. In the other two positions, the ac power is applied to the computer power supply and the cabinet power control contacts are short-circuited. In the POWER position, the console function switches (the right six switches in Figure 4-1) are fully operative. In the PANEL LOCK position, the console function switches have no effect on the computer's operation. PANEL LOCK is used to secure a running computer from mischievous tampering.

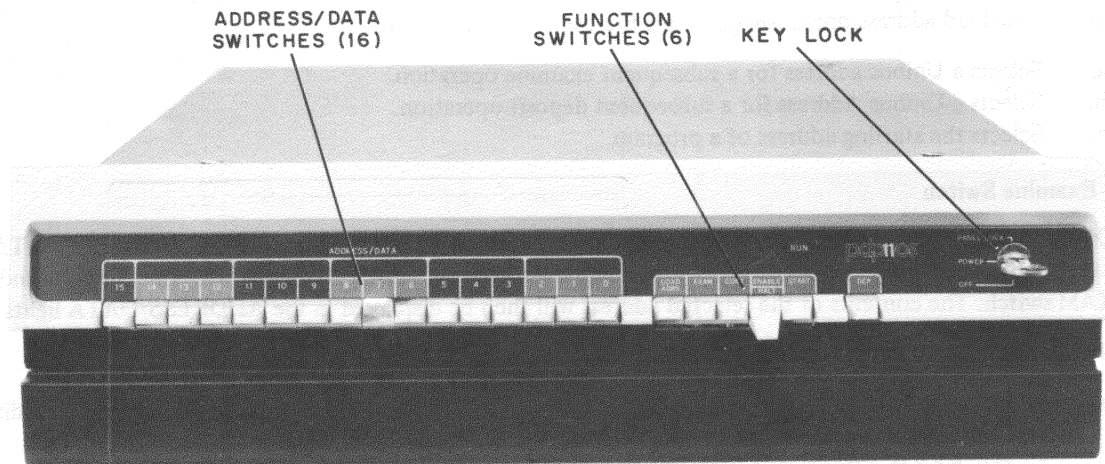

Figure 4-1 Console Illustrating Switch Movements

4.3 FUNCTION SWITCHES

The right six switches in Figure 4-1 are called function switches. They are listed below in order of their appearance from left to right.

1. LOAD ADRS (load address)
2. EXAM (examine)
3. CONT (continue)
4. ENABLE/HALT
5. START
6. DEP (deposit)

Function switches 1 through 5 are actuated by being depressed as is the ENABLE/HALT switch in Figure 4-1. The DEP switch must be lifted for actuation. All of the function switches, with the exception of ENABLE/HALT, are spring loaded and return to their rest state when released.

4.4 ADDRESS/DATA SWITCHES

The 16 ADDRESS/DATA switches are to the left of the function switches (Figure 4-1). These 2-position switches represent a manually set flip-flop register with the up position representing a logical 1 and the down position a logical 0. The ADDRESS/DATA switches may be used in conjunction with the function switches or in conjunction with a program stored in the computer's memory. The ADDRESS/DATA switches are often referred to as the Switch Register in DEC documentation. In Figure 4-1, the contents of the Switch Register is equal to 200_8 because bit 7 is set to a 1 and all others are set to a 0.

4.5 CONSOLE INDICATORS

There are 17 indicators on the computer console. The contents of the 16 ADDRESS/DATA lights either represent a 16-bit Unibus address or the contents of a 16-bit Unibus address. Note that the state of the ADDRESS/DATA lights is defined only when the computer RUN light is not illuminated.

4.6 CONSOLE OPERATION

The following paragraphs describe the operation of the function switches. Table 4-1 indicates the meaning of the ADDRESS/DATA lights for all cases where the contents of these lights are defined.

4.6.1 Load Address Switch

Depressing the LOAD ADRS switch when the computer is halted causes the contents of the Switch Register to be stored in a temporary register within the computer. This data is also displayed in the ADDRESS/DATA lights for verification. The load address operation performs the following functions:

- a. Selects a Unibus address for a subsequent examine operation.
- b. Selects a Unibus Address for a subsequent deposit operation.
- c. Selects the starting address of a program.

4.6.2 Examine Switch

The EXAM switch permits the display of the contents of a selected Unibus address in the ADDRESS/DATA lights. Select the appropriate address in the Switch Register and depress the LOAD ADRS switch. Then depress and release the EXAM switch. The contents of the selected address will then be displayed in the ADDRESS/DATA lights.

Several features are built into the examine function to aid in programming the computer.

- a. While the EXAM switch is depressed, the address to be examined is displayed. The data itself is displayed when the switch is released.
- b. If the EXAM switch is repeatedly depressed, the Unibus address is incremented by two on each depression*. This permits the examination of a list of addresses without repeated load address operations.

*The Unibus address is incremented by one when examining general registers.

Table 4-1
Significance of ADDRESS/DATA Indicators

Action	Qualification	Information Displayed In ADDRESS/DATA Indicators
Power On	<ol style="list-style-type: none"> 1. ENABLE/HALT switch in HALT position 2. ENABLE/HALT switch in ENABLE position 	<ol style="list-style-type: none"> 1. Contents of location (24)₈ 2. Undefined – depends on contents of memory
Load Address	LOAD ADRS switch depressed	Contents of Switch Register
Examine	<ol style="list-style-type: none"> 1. EXAM switch depressed 2. EXAM switch released 	<ol style="list-style-type: none"> 1. Unibus address that is to be examined 2. Contents of Unibus address that was examined
Deposit	<ol style="list-style-type: none"> 1. DEP switch raised 2. DEP switch released 	<ol style="list-style-type: none"> 1. Unibus address that is to be deposited 2. Contents of Switch Register which is the data deposited
RUN Light On		Undefined
Program Halt	<ol style="list-style-type: none"> 1. ENABLE/HALT switch in HALT position 2. HALT instruction executed 3. Double bus error which is two successive attempts to access non-existent memory or improper odd byte address. 	<ol style="list-style-type: none"> 1. Address of instruction to be executed when CONT switch is actuated 2. Same as 1 3. Contents of program counter (R7) at time double bus error occurred
Program Execution	<ol style="list-style-type: none"> 1. START switch depressed 2. CONT switch depressed 	<ol style="list-style-type: none"> 1. Address of last load address 2. Address of instruction to be executed

- c. If an attempt is made to examine non-existent memory, it is necessary to perform the initialize operation explained in Paragraph 4.7.
- d. Only full words are displayed in the ADDRESS/DATA lights; thus, bit 0, the byte address bit, is ignored when using the EXAM switch with the following exception. Note that the general registers are located on byte addresses. Therefore, when examining the general registers, address bit 0 is recognized and the increment feature is modified such that sequential registers may be examined by repeated use of the EXAM switch.

Note that the EXAM switch has no effect while the computer is in the RUN state or when the key operated power switch is in the PANEL LOCK position.

4.6.3 Deposit Switch

The physical operation of the DEP switch requires that it be lifted for actuation. The DEP switch permits the contents of the Switch Register to be deposited in a Unibus address, which is typically specified by a previous load address operation. To deposit the instruction BRANCH SELF (777₈) in location 200₈, first set the Switch Register to 200₈ as shown in Figure 4-1 and actuate the LOAD ADRS switch. Set the Switch Register to 777₈ then lift and release the DEP switch.

Several additional features are built into the deposit function:

- a. While the DEP switch is actuated, the Unibus address to be effected is displayed in the ADDRESS/DATA lights. When the switch is released, the data deposited is displayed for verification.
- b. If the DEP switch is repeatedly depressed, the Unibus address is incremented by two on each depression*. This permits the depositing of an entire program with only one load address operation.
- c. If an attempt is made to deposit into non-existent memory, it is necessary to perform the initialize operation explained in Paragraph 4.1.
- d. All deposit operations affect full 16-bit words. Bit 0 of the address is used only when depositing into general registers, otherwise, bit 0 of the address is ignored.

4.6.4 ENABLE/HALT Switch

Place the ENABLE/HALT switch in the HALT position (Figure 4-1); the computer will halt at the end of the current instruction, providing the key switch is not in the PANEL LOCK position. All interrupts and traps will be executed prior to halting. This switch may be used in conjunction with the CONT switch to step through programs (Paragraph 4.6.6). With the ENABLE/HALT switch in the ENABLE position, programs may be executed once started by: actuating the START switch, actuating the CONT switch, and the auto-restart power-up sequence.

4.6.5 START Switch

The sequence for starting a program from the console is as follows:

1. Set the starting address of the program in the Switch Register.
2. Depress the LOAD ADRS switch.
3. Position the ENABLE/HALT switch in the ENABLE position.
4. Depress and release the START switch.

While the START switch is depressed, the following actions occur:

1. An initialize signal is generated on the Unibus. This initialize signal serves to reset all peripherals.
2. The program status word is reset to zero.
3. The program counter, R7, is loaded with the last address loaded with the LOAD ADRS switch.

When the START switch is released, program execution begins with the instruction contained in the location specified by R7 and the RUN light is turned on. If the ENABLE/HALT switch is in the HALT position, the computer remains in the HALT state following the release of the START switch.

*The Unibus address is incremented by one when depositing into general registers.

Observe the following precautions when using the START switch:

- a. If the keylock is not in the PANEL LOCK position, depressing the START switch while a program is running initializes the computer system and restarts the program.
- b. It is good practice to precede every program start with a load address operation.
- c. A program should not be started at an odd address or the first fetch operation will be aborted and an odd address trap will be attempted. If the stack pointer, R6, is not properly set up, the program in memory may be destroyed.

4.6.6 Continue Switch

The CONT switch is used to continue a program without altering the program counter, R7, or the machine state. To continue a halted program, depress and release the CONT switch. The program is resumed when the CONT switch is released.

The CONT switch is used with the ENABLE/HALT switch to step through programs one instruction at a time. If the CONT switch is actuated while the ENABLE/HALT switch is in the HALT position (Figure 4-1), a single instruction will be executed. Note that interrupts are serviced in single instruction mode. In single step mode, the address of the next instruction to be executed is displayed in the lights.

4.7 UNCONDITIONAL COMPUTER AND UNIBUS INITIALIZATION

Unconditional initialization of the computer system usually occurs because of an attempt to examine from, or deposit into, non-existent memory from the console. However, a peripheral or processor error may occur that can only be overcome by initializing the system from the console. The procedure is simply to depress the START switch with the ENABLE/HALT switch in the HALT position.

4.8 LOADING PROGRAMS FROM PAPER TAPE

When the computer is first received, the content of its memory is not defined (it knows absolutely nothing, not even how to receive paper-tape input). However, the computer can accept data when toggled directly into core using the console switches. The Bootstrap Loader program is the first program to be loaded, and therefore must be toggled into core. The loaders described in this section facilitate the loading of programs from either the low or high speed paper-tape reader. The low speed reader is part of the Model 33 ASR Teletype and is operated via the SCL. The high speed reader is DEC part number PC-11.

The Bootstrap Loader program instructs the computer to accept and store in core data that is punched on paper tape in bootstrap format. The Bootstrap Loader is used to load very short paper-tape programs of 162_8 16-bit words or less (primarily the Absolute Loader and Memory Dump programs). Programs longer than 162_8 16-bit words must be assembled into absolute binary format using the PAL-11A Assembler and loaded into memory using the Absolute Loader.

The Absolute Loader (Paragraph 4.8.2) is a system program that enables data punched on paper-tape in absolute binary format to be loaded into any available memory bank. It is used primarily to load the paper-tape system software (excluding certain subprograms) and object programs assembled with PAL-11A.

The loader programs are loaded into the upper most area of available memory so that they will be available for use with system and user programs. When writing programs, the locations used by the loaders should not be used without restoring their contents; otherwise, the loaders will have to be reloaded because the object program will have altered them.

Memory Dump programs are used to print or punch the contents of specified areas of memory. For example, when developing or debugging user programs, it is often necessary to get a copy of the program or portions of memory.

There are two dump programs supplied in the paper-tape software system: DUMPIT, which prints or punches the octal representation of all or specified portions of memory; and DUMPAB, which punches all or specified portion of memory in absolute binary format suitable for loading with the Absolute Loader.

4.8.1 The Bootstrap Loader

The Bootstrap Loader should be loaded (toggled) into the highest memory bank. The locations and corresponding instructions of the Bootstrap Loader are listed in Table 4-2 and explained below.

Table 4-2
Bootstrap Loader Instructions

Location	Instruction
XX7744	016701
XX7746	000026
XX7750	012702
XX7752	000352
XX7754	005211
XX7756	105711
XX7760	100376
XX7762	116162
XX7764	000002
XX7766	XX7400
XX7770	005267
XX7772	177756
XX7774	000765
XX7776	YYYYYY

In Table 4-2, XX represents the highest available memory bank. For example, the first location of the loader would be as indicated in Table 4-3, depending on memory size, and XX in all subsequent locations would be the same as the first.

Note in Table 4-3 that the contents of location XX7766 should reflect the appropriate memory bank in the same manner as the preceding locations.

Table 4-3
Memory Bank Assignments

Location	Memory Bank	Memory Size
017744	0	4K
037744	1	8K
057744	2	12K
077744	3	16K
117744	4	20K
137744	5	24K
157744	6	28K

The contents of location XX7776 (YYYYYY in the instruction column of Table 4-2) should contain the device status register address of the paper-tape reader to be used when loading the bootstrap formatted tapes. Either paper-tape reader may be used, and the associated address is specified as follows:

Teletype Paper-Tape Reader – 177560
High Speed Paper-Tape Reader – 177550

4.8.1.1 Loading the Loader Into Memory – With the computer initialized for use as described in Paragraph 4.7, toggle in the Bootstrap Loader as explained below.

1. Set XX7744 in the Switch Register (SR) and press LOAD ADRS switch (XX7744 will be displayed).
2. Set the first instruction, 016701, in the SR and lift DEP switch (016701 will be displayed).

NOTE

When depositing data into consecutive words, the DEP switch automatically increments the address to the next word.

3. Set the next instruction, 000026, in the SR and lift DEP switch. Continue to deposit subsequent instructions.
4. Deposit the desired device status register address in location XX7776, the last location of the Bootstrap Loader.

NOTE

It is a good programming practice to verify that all instructions are stored correctly. Proceed to Step 6.

6. Set XX7744 in the SR and press LOAD ADRS switch.
7. Press and release EXAM switch (the octal instruction in location XX7744 will be displayed so that it can be compared to the correct instruction, 016701). If the instruction is correct, proceed to Step 8, otherwise go to Step 10.
8. Press EXAM switch. The instruction of the location displayed in the ADDRESS/DATA indicators with the switch depressed will be displayed when the switch is released. Compare the indicator contents to the instruction at the proper location.
9. Repeat Step 8 until all instructions have been verified or go to Step 10 if the correct instruction is not displayed.

NOTE

Whenever an incorrect instruction is displayed, it can be corrected by performing Steps 10 and 11.

10. With the incorrect instruction displayed in the ADDRESS/DATA register, set the correct instruction in the SR and lift DEP switch. The contents of the SR will be deposited in the location displayed with the key lifted.
11. Press EXAM switch to ensure that the instruction was correctly stored.

The Bootstrap Loader is now in core. The procedures above are illustrated in the flow chart of Figure 4-2.

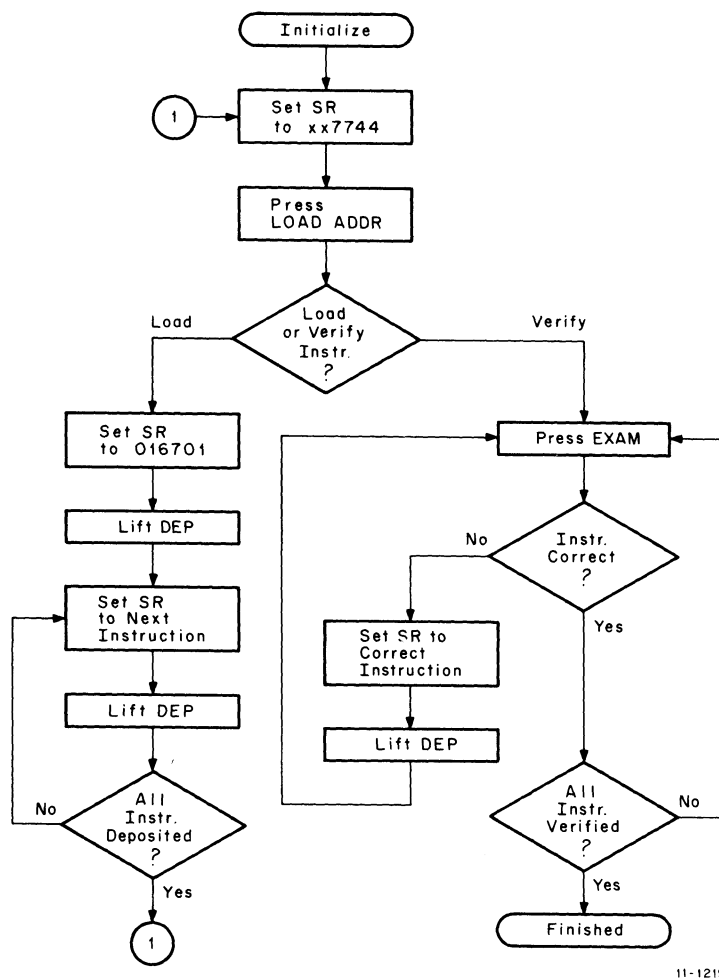

Figure 4-2 Loading and Verifying the Bootstrap Loader

4.8.1.2 Loading Bootstrap Tapes – Any paper tape punched in bootstrap format is referred to as a bootstrap tape and is loaded into memory using the Bootstrap Loader. Bootstrap tapes begin with about two feet of special bootstrap leader code (ASCII code 351, not blank leader tape as is required by the Absolute Loader).

With the Bootstrap Loader in memory, it will load the bootstrap tape into memory starting anywhere between location XX7400 and location XX7743; i.e., 162₈ words. The paper-tape input device used is specified in location XX7776. Bootstrap tapes are loaded into memory as explained below:

1. Set the ENABLE/HALT switch to HALT.
2. Place the bootstrap tape in the specified reader with the special bootstrap leader code over the reader sensors (under the reader station).
3. Set the SR to XX7744 (the starting address of the Bootstrap Loader) and press LOAD ADRS switch.
4. Set the ENABLE/HALT switch to ENABLE.
5. Press START switch. The bootstrap tape will pass through the reader as data is being loaded into memory.

6. The bootstrap tape stops after the last frame of data (Figure 4-5) has been read into memory. The program on the bootstrap is now in memory.

The procedures above are illustrated in the flowchart of Figure 4-3.

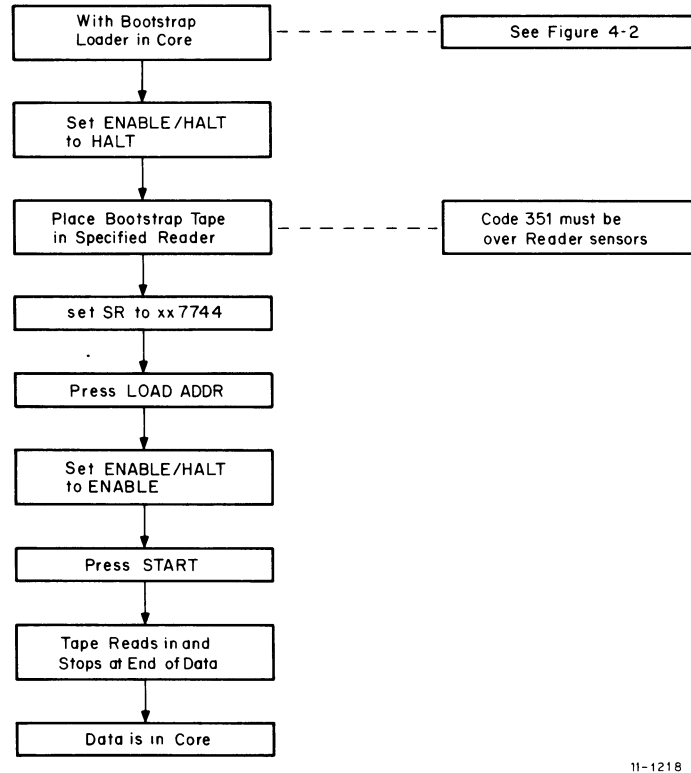

Figure 4-3 Loading Bootstrap Tapes Into Memory

If the bootstrap tape does not read in immediately after depressing the START switch, it is due to one of the following reasons:

- a. Bootstrap Loader not correctly loaded
- b. Using the wrong input device
- c. Code 351 not directly over the reader sensors
- d. Bootstrap tape not properly positioned in reader

4.8.1.3 Bootstrap Loader Operation – The Bootstrap Loader source program is shown below. The starting address in the example denotes that the program is to be loaded into memory bank zero (a 4K system).

The Bootstrap Loader source program is a brief but fairly complex example of the PAL-11A Assembly Language. Explanations of the program and PAL-11A are found in the *PDP-11 Paper-Tape Software Programming Handbook*, DEC-11-GGPB-D.

	000001		R1=%1	;USED FOR THE DEVICE ;ADDRESS
	000002		R2 %2	;USED FOR THE LOAD AD- ;DRESS DISPLACEMENT
	017400		LOAD=17400	;DATA MAY BE LOADED NO ;LOWER THAN THIS
	017744		.-17744	;START ADDRESS OF THE ;BOOTSTRAP LOADER
017744	016701	START:	MOV DEVICE, R1	;PICK UP DEVICE ADDRESS, ;PLACE IN R1
	000026			
017750	012702	LOOP:	MOV #.-LOAD+2, R2	;PICK UP ADDRESS ;DISPLACEMENT
	000352			
017754	005211	ENABLE:	INC @ R1	;ENABLE THE PAPER TAPE
017756	105711	WAIT:	TSTD @ R1	;READER ;WAIT UNTIL FRAME ;IS AVAILABLE
017760	100376		BPL WAIT	
017762	116162		MOVB 2(R1), LOAD (R2)	;STORE FRAME READ ;FROM TAPE IN MEMORY
	000002			
	017400			
017770	005267		INC LOOP+2	;INCREMENT LOAD ADDRESS ;DISPLACEMENT
	177756			
017774	000765	BRNCH:	BR LOOP	;GO BACK AND READ MORE ;DATA
017776	000000	DEVICE:	0	;ADDRESS OF INPUT DEVICE

4.8.2 The Absolute Loader

The Absolute Loader is a system program that enables data punched on paper tape in absolute binary format to be loaded into any memory bank. It is used primarily to load the paper-tape system software (excluding certain subprograms) and object programs assembled with PAL-11A. The major features of the Absolute Loader include:

- a. Testing of the checksum on the input tape to ensure complete, accurate loads
- b. Starting the loaded program upon completion of loading without additional user action, as specified by the .END in the program just loaded
- c. Specifying the load address of position independent programs at load time rather than at assembly time, by using the desired loader Switch Register option.

4.8.2.1 Loading the Loader Into Memory – The Absolute Loader is supplied on punched paper-tape in bootstrap format, therefore, the Bootstrap Loader is used to load the Absolute Loader into memory. It occupies locations XX7474 through XX7743, and its starting address is XX7500. The Absolute Loader program is 72₁₀ words long, and is loaded adjacent to the Bootstrap Loader.

4.8.2.2 Loading Absolute Tapes – Any paper-tape punched in absolute format is referred to as an absolute tape, and is loaded into memory using the Absolute Loader. When using the Absolute Loader, there are two methods of loading available: normal and relocated.

A normal load occurs when the data is loaded and placed in memory according to the load addresses on the object tape. It is specified by setting bit 0 of the Switch Register to 0 immediately before starting the load.

There are two types of relocated loads:

- a. Loading to continue from where the loader left off after the previous load. This type is used, when the object program being loaded is contained on more than one tape. It is specified by setting the Switch Register to 000001 immediately before starting the load.
- b. Loading into a specific area of memory. This is normally used when loading position independent programs. A position independent program is one that can be loaded and run anywhere in available memory. The program is written using the position independent instruction format. The type of load is specified by setting the Switch Register to the load address and adding 1 to it (i.e., setting bit 0 to 1).

Optional Switch Register settings for the three types of loads are listed below.

Type of Load	Switch Register	
	Bits 1-14	Bit 0
Normal	(ignored)	0
Relocated - continue loading where left off	0	1
Relocated - load in specified area of memory	nnnnn (specified address)	1

The absolute tape may be loaded using either paper-tape reader. The desired reader is specified in the last word of available memory (XX7776). The input device status word may be changed at any time prior to loading the absolute tape. With the Absolute Loader in memory, absolute tapes are loaded as explained below:

1. Set the ENABLE/HALT switch to HALT. To use an input device other than that used for loading the Absolute Loader, change the address of the device status word (in location XX7776) to reflect the desired device; i.e., 177560 for the Teletype reader or 177550 for the high-speed reader.
2. Set the SR to XX7500 and press LOAD ADRS switch.
3. Set the SR to reflect the desired type of load.
4. Place the absolute tape in the proper reader with blank leader tape directly over the reader sensors.
5. Set ENABLE/HALT switch to ENABLE.
6. Press START switch. The absolute tape will begin passing through the reader station as data is being loaded into memory.

If the absolute tape does not begin passing through the reader station, the Absolute Loader is not in memory correctly. Reload the loader and start over at Step 1. If it halts in the middle of the tape, a checksum error occurred in the last block of data read in.

Normally, the absolute tape will stop passing through the reader station when it encounters the transfer address as generated by the statement .END, denoting the end of a program. If the system halts after loading, check that the low byte of R0 is 0*. If so, the tape is correctly loaded. If not 0, a checksum error has occurred in the block of data just loaded, indicating that some data was incorrectly loaded. The tape should be reloaded starting at Step 1.

*To read R0, load address 177700 and press EXAM switch.

4.8.3 Memory Dumps

A Memory Dump program is a system program that enables the contents of all or any specified portion of memory to be dumped (print or punch) onto the teletype printer and/or punch, line printer, or high speed punch. There are two dump programs available in the paper-tape software system:

- a. DUMPIT, which dumps the octal representation of the contents of specified portions of memory onto the teleprinter, low speed punch, high speed punch, or line printer.
- b. DUMPAB, which dumps the absolute binary code of the contents of specified portions of memory onto the low speed or high speed punch.

Both dump programs are supplied on punched paper tape in bootstrap and absolute binary formats. Paragraph 4.8.1.3 explains how the Absolute Loader is loaded over the bootstrap tapes. The absolute binary tapes are position independent and may be loaded and run anywhere in memory as explained in Paragraph 4.8.2.2. DUMPIT and DUMPAB are very similar in function; they differ primarily in the type of output they produce.

4.8.3.1 Operating Procedures – Neither dump program will punch leader or trailer tape, but DUMPAB will always punch ten blank frames of tape at the start of each block of data dumped.

The operating procedures for both dump programs follow:

1. Select the dump program desired and place it in the reader specified by location XX7776 (Paragraph 4.8.1).
2. If a bootstrap tape is selected, load it using the Bootstrap Loader (Paragraph 4.8.1.2). When the computer halts, go to Step 4.
3. If an absolute binary tape is selected, load it using the Absolute Loader (Paragraph 4.8.2.2), relocating as desired.

Place the proper start address in the Switch Register, press LOAD ADRS and START switches. (The start addresses are shown in Paragraph 4.8.3.3.)

4. When the computer halts, enter the address of the desired output device status register in the Switch Register and press CONT switch (low speed punch and teleprinter = 177564; high speed punch = 177554; line printer = 177514).
5. When the computer halts, enter in the Switch Register the address of the first byte to be dumped and press CONT switch. This address must be even when using DUMPIT.
6. When the computer halts again, enter in the Switch Register the address of the last byte to be dumped and press CONT switch. When using the low speed punch, set the punch to ON before pressing CONT switch.
7. Dumping will now proceed on the selected output device.
8. When dumping is complete, the computer will halt.

If further dumping is desired, proceed to Step 5. It is not necessary to respecify the output device address except when changing to another output device. In such a case, proceed to the second paragraph of Step 3 to restart.

If DUMPAB is being used, a transfer block must be generated as described below. If a tape read by the Absolute Loader does not have a transfer block, the loader will wait in an input loop. In such a case, the program may be

manually initiated, however, this practice is not recommended because there is no guarantee that load errors will not occur when the end of the tape is read.

The transfer block is generated by performing Step 5 with the transfer address in the Switch Register, and Step 6 with the transfer address minus 1 in the Switch Register. If the tape is not to be self-starting, an odd-numbered address must be specified in Step 5 (e.g., 000001).

The dump programs use all eight general registers and do not restore their original contents. Therefore, after a dump, the general registers should be loaded as necessary prior to their use by subsequent programs.

4.8.3.2 Output Formats – The octal output from DUMPIT is in the following format:

XXXXXX>YYYYYY YYYYYY YYYYYY YYYYYY YYYYYY YYYYYY

Where XXXXXX is the address of the first location printed or punched, and YYYYYY are words of data, the first of which starts at location XXXXXX. This is the format for every line of output. There are only eight words of data per line, but there can be as many lines as needed to complete the dump.

The output from DUMPAB is in absolute binary.

4.8.3.3 Storage Maps – The DUMPIT program is 87 words long. When used in absolute format, the storage map is as shown in Figure 4-4.

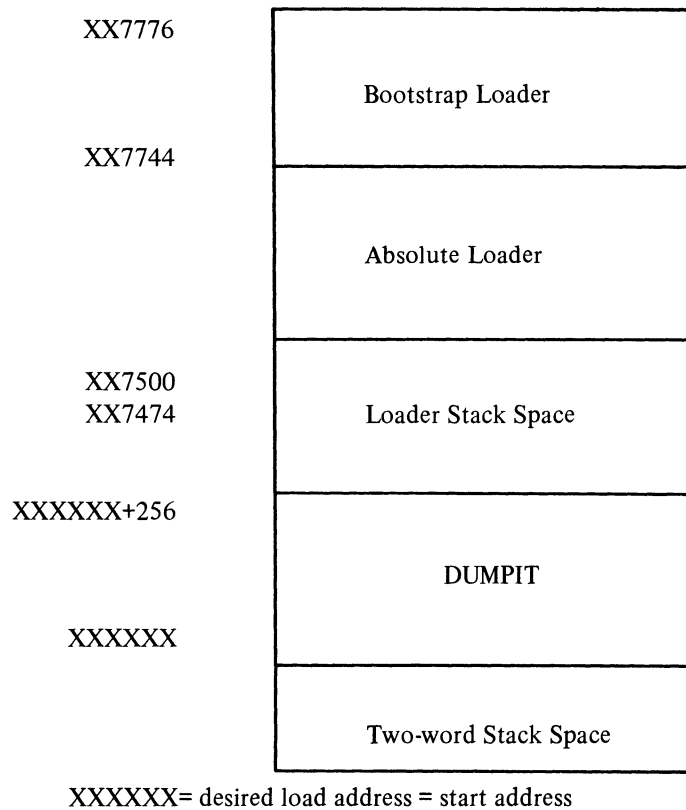

Figure 4-4 Absolute Format

When used in bootstrap format, the storage map is as shown in Figure 4-5.

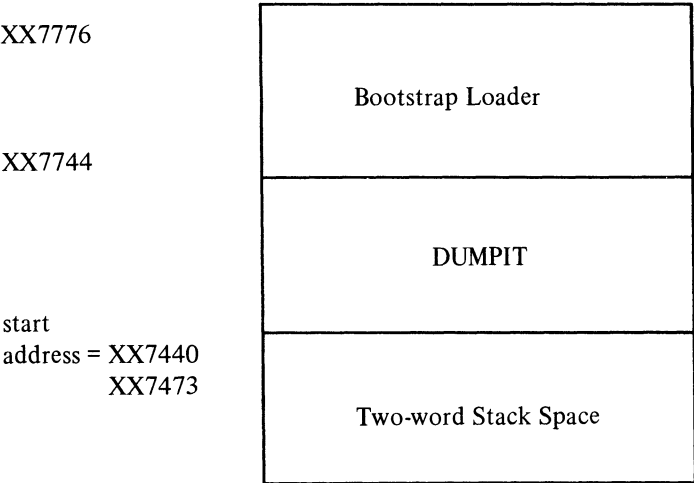

Figure 4-5 Bootstrap Format

PART 2

KD11-B PROCESSOR

Part 2 provides both general and detailed descriptions of the KD11-B processor and its console, a description of the PDP-11 instruction set, a description of the KD11-B microprogram, and maintenance information. The chapters in Part 2 are:

- Chapter 5 – Processor General Description
- Chapter 6 – Instruction Set
- Chapter 7 – Console Description
- Chapter 8 – KD11-B Detailed Description
- Chapter 9 – Microprogram Control
- Chapter 10 – KD11-B and Console Maintenance

The general description of the KD11-B consists of defining the processor and illustrating its use with peripherals and the Unibus. The KD11-B processor print set found in the *Engineering Drawing Manual* is often referenced in the KD11-B logic description.

CHAPTER 5

PROCESSOR GENERAL DESCRIPTION

5.1 INTRODUCTION

This chapter provides a brief definition of the KD11-B processor. It also lists the logic prints that are referenced in subsequent paragraphs and explains the symbology and notations used in these prints. A sample ROM map listing is included.

5.2 KD11-B DEFINITION

The KD11-B is a program compatible with the KA11 used in the PDP-11/15 and PDP-11/20, although the KD11-B executes instructions somewhat more slowly. The instruction set of the KD11-B is described in detail in Chapter 6, along with some slight differences between the KD11-B and the KA11 (PDP-11/20).

Physically the KD11-B consists of two 8-1/2 by 15 inch modules, the M7260 and M7261. Each module contains approximately 100 dual in-line integrated circuits of the 14-, 16-, and 24-pin variety. There is one MOS-LSI 40-pin integrated circuit used on the M7260. This MOS circuit is the serial communication line (SCL) receiver and transmitter. All other integrated circuits used on the KD11-B are bipolar. The connections between the two modules are made through the backplane.

The KD11-B programmer's console interfaces to the processor via a 40-conductor cable that is attached to the M7260 module. The console is described in detail in Chapter 7.

5.3 KD11-B AND THE UNIBUS

The processor is interfaced with memory and most peripherals by the Unibus as shown in Figure 5-1. The KD11-B is capable of arbitrating bus requests (BR) and non-processor requests (NPR) as they are asserted onto the Unibus by the connected peripherals.

The line clock and the serial communications line (SCL) do not interface with the processor via the Unibus in the traditional PDP-11 sense; both connect to the KD11-B through an internal bus. For most programs, these peripherals are indistinguishable from their appearance on other PDP-11 implementations. In other words, the program may access the line clock and the serial communications line by using instructions that move data to and from the Unibus address specified for these peripheral options in the *PDP-11 Peripherals and Interfacing Handbook*. These Unibus addresses are as follows:

- a. Line Clock Status Register Address = 177546
- b. SCL Receiver Status Register Address = 177560
- c. SCL Receiver Buffer Register Address = 177562
- d. SCL Transmitter Status Register Address = 177564
- e. SCL Transmitter Buffer Register Address = 177566

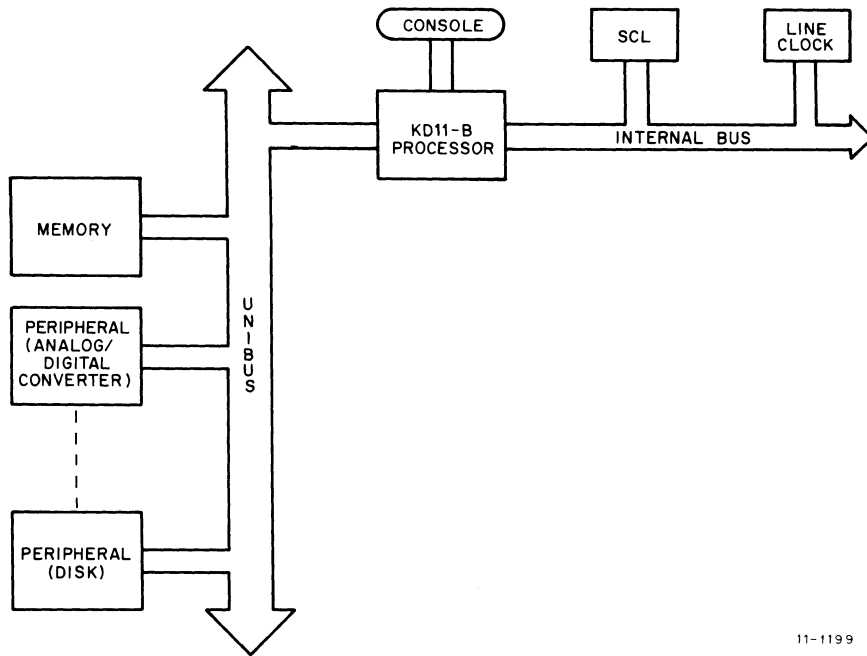

11-1199

Figure 5-1 KD11-B With Interconnections to Memory and Peripherals

It is not possible for the line clock and SCL to be addressed by any devices attached to the Unibus other than the KD11-B processor. For example, it is not possible to perform NPRs to the SCL from another peripheral such as the DECTape unit.

The SCL input/output is available for connection to such devices as the LA30 DECwriter, the VT05 CRT Terminal, or the Model 33 ASR Teletype. These SCL input/output signals interface at the fingers of the processor's M7260 module via a Berg connector located on the rear of the computer chassis as shown in Chapter 3.

5.4 KD11-B AS AN INSTRUCTION INTERPRETER

Figure 5-2 illustrates the division of the KD11-B into Unibus control and instruction interpreter. This division is significant because in the KD11-B the Unibus control is implemented as a block of logic that is relatively independent of the rest of the processor.

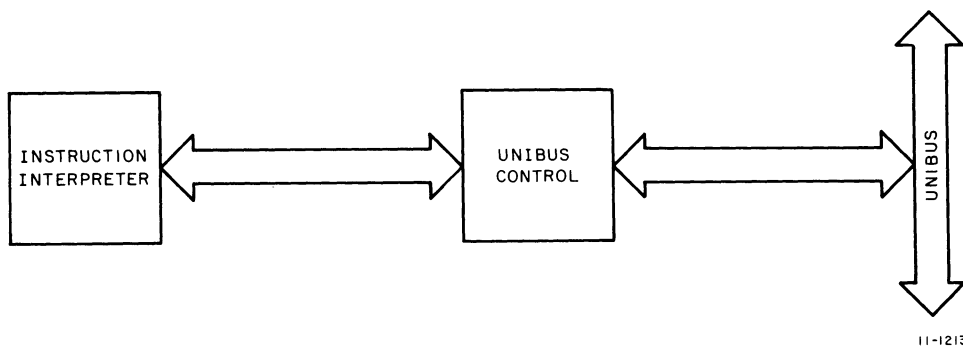

11-1213

Figure 5-2 KD11-B Processor Block Diagram

In Figure 5-3, the instruction interpreter is further divided into a data path (DP), a data path control (DPC), and a control store (CS). Whenever power is applied to the computer, the DPC continually executes a program that is stored in the CS. All instructions, interrupt sequences, and console functions are performed by the DPC when executing a microprogram contained in the CS. The Unibus control and the DP are facilities used by the DPC in the course of performing its tasks. The program contained in the CS is referred to as the microprogram.

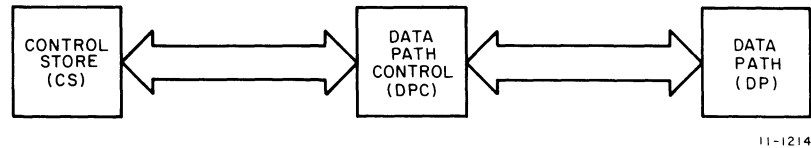

Figure 5-3 Instruction Interpreter Block Diagram

5.5 KD11-B PRINT SET

Throughout the remainder of Part 2, frequent references are made to the drawings in the KD11-B print set located in the *Engineering Drawing Manual*. Each print with its respective engineering drawing number is listed as follows:

- a. The Data Path (M7260): D-CS-M7260-0-01 (9 sheets, DPA to DPH1)
- b. The Control Module (M7261): D-CS-M7261-0-01 (11 sheets, CONA to CONJ)
- c. The Console: D-CS-5409766-0-1
- d. Microprogram Flow Listing: K-MP-KD11-B-1
- e. Microprogram Symbolic Listing: K-MP-KD11-B-2
- f. Microprogram Binary Listing: K-MP-KD11-B-3
- g. Microprogram Cross Reference Listing: K-MP-KD11-B-4
- h. Read-Only Memory Maps (ROM): K-RL-M7260-8, K-RL-M7261-8

For this discussion, the prints are referenced by the designations DPA through DPH for the M7260, and CONA through CONF for the M7261. As a general rule, all small scale integrated circuits are shown as individual logic equivalent gates or flip-flops, with pin numbers designated. Figure 5-4 shows an example of a positive NAND gate and a D-type flip-flop.

The E094 contained within the gate (Figure 5-4) indicates the physical location of the dual in-line integrated circuit on the appropriate module. Integrated circuit pins are referenced, using the notation E09403. The first three digits after the E refer to the location of the integrated circuit on the module, and the next two digits are the pin number on that integrated circuit. The prefix of the output signal, in this case DPF, indicates the print name on which the gate appears; the prefix of the input signal indicates the print page from which the input signal originates (e.g., DPG, DPF). The particular gate illustrated in Figure 5-4 appears on drawing F (D-CS-M7260-0-01, sheet 7). The gate appearing on print DPF is physically located on the M7260 module; however, the input signals come from prints DPG and DPF, and therefore the input signals originate on the M7260 module. Note that signal names with the prefix CONC might originate on CONC or CONC1. Similarly, signal names with the prefix DPH might originate on DPH or DPH1.

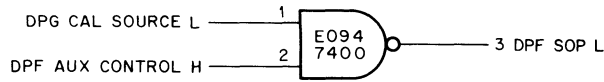

a) 2 Input Positive Nand Gate.

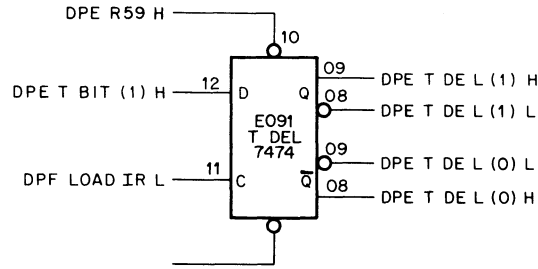

b) Typical 7474 Flip-Flop

11-1198

Figure 5-4 Typical Small Scale Integrated Circuit Representations

Figure 5-4 depicts a typical 7474 flip-flop which appears on drawing DPE (D-CS-M7260-0-1, sheet 6). Several important points are shown: the name of the flip-flop (TDEL); the print it appears on (DPE); and its physical location (E091). Four possible output signal names are available from the two physical outputs of the flip-flop:

Physical Output	Signal Names
Q	DPE TDEL (1)H DPE TDEL (1)L
\overline{Q}	DPE TDEL (0)L DPE TDEL (0)L

To clock a 7474 flip-flop there must be a pulse input of some duration (t_p) to the clock pin. The clock signal for the 7474 flip-flop is shown in Figure 5-5. Note that the signal DPF LOAD IR L is a negative-going pulse. Since the 7474 flip-flop is clocked on the rising edge of a signal, the flip-flop T DEL is clocked on the trailing edge of DPF LOAD IR L.

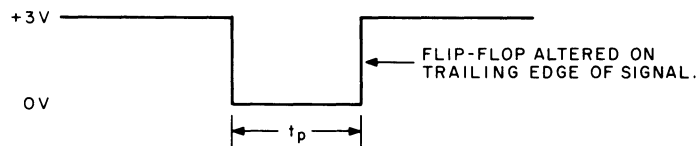

11-1201

Figure 5-5 DPF LOAD IR L Signal

5.5.1 Medium and Large Scale Integrated Circuit Representations

MSI and LSI integrated circuits (Figure 5-6) are represented in the KD11-B print set as rectangles with inputs on the left and outputs on the right. Control lines often enter the IC from the bottom. The functional descriptions of the KD11-B MSI and LSI ICs are contained in Appendix A.

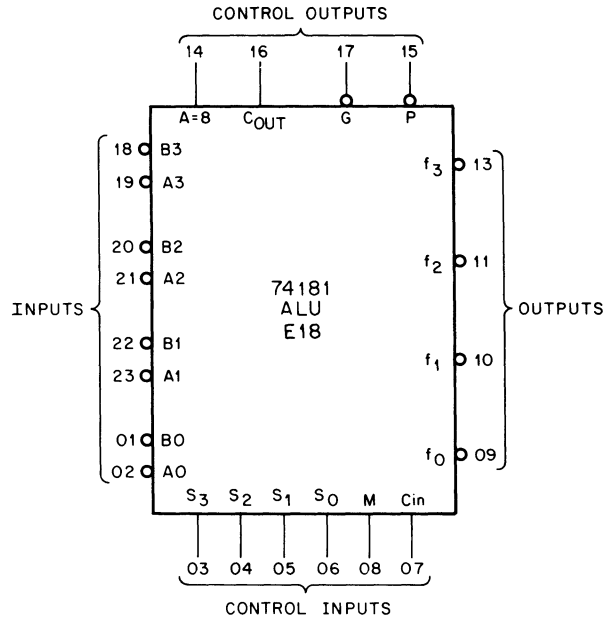

11-1197

Figure 5-6 ALU, MSI Circuit Type 74181 Representation

5.5.2 Microprogram Documentation

The microprogram is documented at three levels in the print set. The first level is the microprogram flow listing (K-MP-KDN-B-1), at this level, the microprogram is described in terms of register transfers. The microprogram symbolic listing (K-MP-KD11-B-2) shows how the microprogram accomplishes each step. (References in the microprogram listing are symbolic; e.g., scratch pad address = R7.) The binary equivalent is shown in the microprogram binary listing (K-MP-KD11-B-3), which actually shows the binary contents of each word of the microprogram. The microprogram cross reference listing lists the microprogram by address (K-MP-KD11-B-4). The microprogram is discussed in detail in Chapter 9.

5.5.3 Read-Only Memory (ROM) Maps

Figure 5-7 is a typical ROM map listing. ROM map listings for the ROMs used in the KD11-B processor are provided in the *Engineering Drawing Manual* (K-RL-M7260-8 and K-RL-M7261-8).

```

/(\ =Y8 (PIN #9) CONA INT TRAN SYNC L
*/(\ =Y7 (PIN #7) CONA REG ADDR L
***/(\ =Y6 (PIN #6) CONA RECEIVE L
*****/(\ =Y5 (PIN #5) CONA TRANSMIT L
******/(\ =Y4 (PIN #4) CONA LOAD MODEM PSW L
*****/(\ =Y3 (PIN #3) CONA LOAD L CLK PSW L
******/(\ =Y2 (PIN #2) CONG SP WRITE L
******/(\ =Y1 (PIN #1) CONG LOAD PSW L
*****
OCTAL
ADDRESS 000 001 002 003 004 005 006 007 010 011 012 013 014 015 016 017 020 021 022 023 024 025 026 027 030 031 032 033 034 035 036 037
DECIMAL
ADDRESS 0 1 2 3 4 5 6 7 8 9 10 11 12 13 14 15 16 17 18 19 20 21 22 23 24 25 26 27 28 29 30 31
EDCBA
00000 00001 00010 00011 00100 00101 00110 00111 01000 01001 01010 01011 01100 01101 01110 01111 10000 10001 10010 10011 10100 10101 10110 10111 11000 11001 11010 11011 11100 11101 11110 11111
11111111 11111111 11111111 11111111 01111110 11111111 01111011 11111111 00111101 10111111 01111111 11111111 11111111 11111111 01111111 11111111 01010111 11011111 01100111 11101111 01011111 11011111 01101111 11101111 11111111 11111111 11111111 11111111 11111111 11111111 11111111 11111111 11111111
377 377 377 377 176 377 173 377 075 277 177 377 377 377 177 377 127 337 147 357 137 337 157 357 377 377 377 377 377 377 377 377
PSW .TRAN OUT BA=177776
PSW .TRAN OUT,BAR
LCLK .TRANOUT
LCLK .TRANOUT,BAR
GR<R0:R17> .TRANOUT BA=1777XX
GR<R0:R17> .TRANOUT,BAR
ODD BYTE (LCLK/TK/TP)
SWR .TRANOUT BA=177570
SWR .TRANOUT,BAR
TKS .TRANOUT BA=177560
TKS .TRANOUT,BAR
TPS .TRANOUT BA=177564
TPS .TRANOUT,BAR
TKB .TRANOUT BA=177562
TKB .TRANOUT,BAR
TPB .TRANOUT BA=177566
TPB .TRANOUT,BAR
*****
*****/(\ A(PIN #10) IS CONA TRAN OUT L
***/(\ B(PIN #11) IS Y3 OF F025
*/(\ C(PIN #12) IS Y2 OF F025
*/(\ D(PIN #13) IS Y1 OF F025
/(\ E(PIN #14) IS Y4 OF F025

```

Figure 5-7 E068 ROM Map Example

CHAPTER 6

INSTRUCTION SET

6.1 INTRODUCTION

The KD11-B is defined by its instruction set. The sequences of processor operations are selected according to the instruction decoding. This chapter contains tables that describe the PDP-11 instructions and instruction set addressing modes. Instruction set differences between the PDP-11/05, 11/10 and PDP-11/20 are listed in Table 6-8.

6.2 ADDRESSING MODES

6.2.1 Introduction

Data stored in memory must be accessed and manipulated. Data handling is specified by a PDP-11 instruction (MOV, ADD, etc.) which usually indicates:

- a. The function (operation code).
- b. A general purpose register for locating the source operand and/or a general purpose register for locating the destination operand.
- c. An addressing mode [to specify how the selected register(s) is to be used].

A large portion of the data handled by a computer is usually structured in character strings, arrays, lists, etc. Thus, the PDP-11 is designed to handle structured data efficiently and flexibly. The general registers may be used with an instruction in any of the following ways:

- a. As accumulators. The data to be manipulated resides within the register.
- b. As pointers. The contents of the register are the address of the operand, rather than the operand itself.
- c. As pointers that automatically step through core locations. Automatically stepping forward through consecutive core locations is termed autoincrement addressing; automatically stepping backwards is termed autodecrement addressing. These modes are particularly useful for processing tabular data.
- d. As index registers. In this instance, the contents of the register and the word following the instruction are summed to produce the address of the operand. This allows easy access to variable entries in a list.

PDP-11s also have instruction addressing mode combinations that facilitate temporary data storage structures for convenient handling of data that must be frequently accessed. This is known as the "stack".

In the PDP-11 any register can be used as a stack pointer under program control; however, certain instructions associated with subroutine linkage and interrupt service automatically use register 6 as a hardware stack pointer. For this reason, R6 is frequently referred to as the SP.

Two types of instructions utilize the addressing modes: single operand and double operand. Figure 6-1 shows the formats of these two types of instructions. The addressing modes are listed in Table 6-1.

6.2.2 Instruction Timing

The PDP-11 is an asynchronous processor in which, in many cases, memory and processor operations are overlapped. The execution time for an instruction is the sum of a basic instruction time and the time to determine and fetch the source and/or destination operands. Table 6-2 shows the addressing times required for the various modes of addressing source and destination operands. All times stated are subject to $\pm 10\%$ variation.

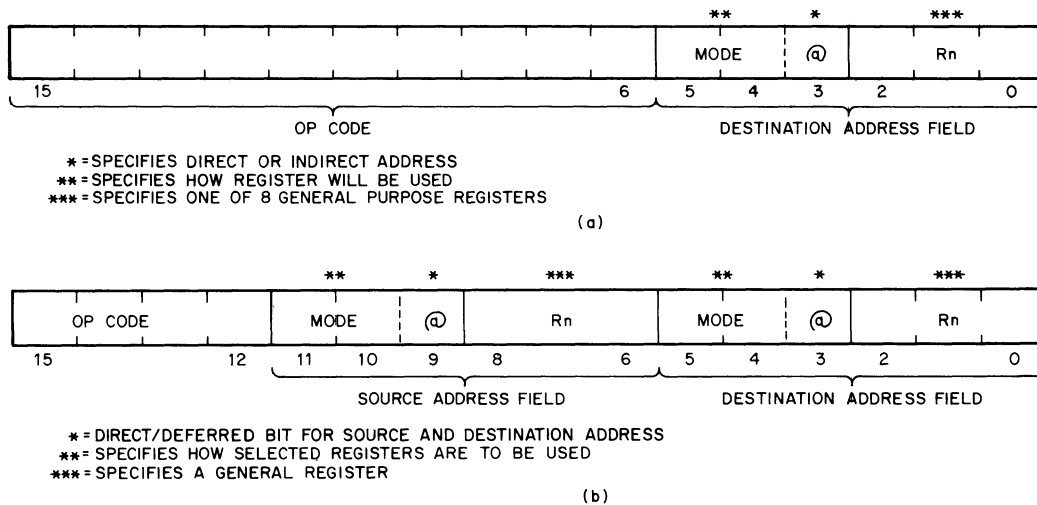

11-1227

Figure 6-1 Addressing Mode Instruction Formats

6.3 PDP-11/05 INSTRUCTIONS

The PDP-11 instructions can be divided into five groupings:

- a. Single Operand Instructions (shifts, multiple precision instructions, rotates)
- b. Double Operand Instructions (arithmetic and logical instructions)
- c. Program Control Instructions (branches, subroutines, traps)
- d. Operate Group Instructions (processor control operations)
- e. Condition Codes Operators (processor status word bit instructions)

Tables 6-3 through 6-7 list each instruction, including byte instructions for the respective instruction groups. Figure 6-2 shows the six different instruction formats of the instruction set, and the individual instructions in each format.

6.4 INSTRUCTION SET DIFFERENCES

Table 6-8 lists the differences between the PDP-11/20 and PDP-11/05 instruction sets.

**Table 6-1
Addressing Modes**

Binary Code	Name	Assembler Syntax	Function
DIRECT MODES			
000	Register	Rn	Register contains operand.
010	Autoincrement	(Rn) +	Register contains address of operand. Register contents incremented after reference.
100	Autodecrement	-(Rn)	Register contents decremented before reference register contains address of operand.
110	Index	X(Rn)	Value X (stored in a word following the instruction) is added to (Rn) to produce address of operand. Neither X nor (Rn) are modified.
DEFERRED MODES			
001	Register Deferred	@Rn or (Rn)	Register contains the address of the operand.
011	Autoincrement Deferred	@(Rn) +	Register is first used as a pointer to a word containing the address of the operand, then incremented (always by two; even for byte instructions).
101	Autodecrement	@-(Rn)	Register is decremented (always by two; even for byte instructions) and then used as a pointer to a word containing the address of the operand.
111	Index Deferred	@X(Rn)	Value X (stored in a word following the instruction) and (Rn) are added and the sum is used as a pointer to a word containing the address of the operand. Neither X nor (Rn) are modified.
PC ADDRESSING			
010	Immediate	#n	Operand follows instruction.
011	Absolute	@#A	Absolute address follows instruction.
110	Relative	A	Address of A, relative to the instruction, follows the instruction.
111	Relative Deferred	@A	Address of location containing address of A, relative to the instruction, follows the instruction.

Rn = Register

X, n, A = next program counter (PC) word (constant)

**Table 6-2
Addressing Times**

Mode	Addressing Format		Time (μs)	
	Description	Symbolic	Source*	Destination**
0	Register	R	0	0
1	Register Deferred	@R or (R)	0.9	2.4
2	Autoincrement	(R) +	0.9	2.4
3	Autoincrement Deferred	@(R) +	2.4	3.4
4	Autodecrement	- (R)	0.9	2.4
5	Autodecrement Deferred	@ - (R)	2.4	3.4
6	Indexed	$\pm X$ (R)	2.4	3.4
7	Index Deferred	@ $\pm X$ (R) or @ (R)	3.4	4.7

* For Source time, add 1.3 μs for odd byte addressing.

** For destination time, modify as follows:

- a. Add 1.3 μs for odd byte addressing with a non-modifying instruction.
- b. Add 2.4 μs for odd byte addressing with a modifying instruction.
- c. Subtract 1.2 μs for a non-modifying instruction.

Table 6-3
Single Operand Instructions

Mnemonic/ Instruction Time	OP Code	Operation	Condition Codes	Description
CLR CLRB 3.4 μ s	0050DD* 1050DD	$(dst) \leftarrow 0$	N: cleared Z: set V: cleared C: cleared	Contents of specified destination are replaced with zeroes.
COM COMB 3.4 μ s	0051DD 1051DD	$(dst) \leftarrow n (dst)$	N: set if most significant bit of result is 0 Z: set if result is 0 V: cleared C: set	Replaces the contents of the destination address by their logical complement (each bit equal to 0 set and each bit equal to 1 cleared).
INC INCB 3.4 μ s	0052DD 1052DD	$(dst) \leftarrow (dst) + 1$	N: set if result is less than 0 Z: set if result is 0 V: set if (dst) was 077777 C: not effected	Add 1 to the contents of the destination.
DEC DECB 3.4 μ s	0053DD 1053DD	$(dst) \leftarrow (dst) - 1$	N: set if result is less than 0 Z: set if result is 0 V: set if (dst) was 100000 C: not effected	Subtract 1 from the contents of the destination.
NEG NEGB 3.4 μ s	0054DD 1054DD	$(dst) \leftarrow -(dst)$	N: set if result is less than 0 Z: set if result is 0 V: set if result is 100000 C: cleared if result is 0	Replaces the contents of the destination address by its 2's complement. Note that 100000 is replaced by itself.
ADC ADCB 3.4 μ s	0055DD 1055DD	$(dst) \leftarrow (dst) + C$	N: set if result is less than 0 Z: set if result is 0 V: set if (dst) is 077777 and C is 1 C: set if (dst) is 177777 and C is 1	Adds the contents of the C-bit into the destination. This permits the carry from the addition of the low order words/bytes to be carried into the high order result.

Table 6-3 (Cont)
Single Operand Instructions

Mnemonic/ Instruction Time	OP Code	Operation	Condition Codes	Description
SBC SBCB 3.4 μ s	0056DD 1056DD	$(dst) \leftarrow (dst) - C$	N: set if result is less than 0 Z: set if result is 0 V: set if (dst) was 100000 C: cleared if (dst) is 0 and C is 1	Subtracts the contents of the C-bit from the destination. This permits the carry from the subtraction of the low order words/bytes to be subtracted from the high order part of the result.
TST TSTB 3.4 μ s	0057DD 1057DD	$(dst) \leftarrow (dst)$	N: set if result is less than 0 Z: set if result is 0 V: cleared C: cleared	Sets the condition codes N and Z according to the contents of the destination address.
ROR RORB 3.4 μ s	0060DD	$(dst) \leftarrow (dst)$ rotate right one place.	N: set if high order bit of the result is set Z: set if all bits of result are 0 V: loaded with the exclusive-OR of the N-bit and the C-bit as set by ROR	Rotates all bits of the destination right one place. The low order bit is loaded into the C-bit and the previous contents of the C-bit are loaded into the high order bit of the destination.
ROL ROLB 3.4 μ s	0061DD 1061DD	$(dst) \leftarrow (dst)$ rotate left one place.	N: set if the high order bit of the result word is set (result < 0); cleared otherwise Z: set if all bits of the result word = 0; cleared otherwise V: loaded with the exclusive-OR of the N-bit and C-bit (as set by the completion of the rotate operation) C: loaded with the high order bit of the destination	Rotate all bits of the destination left one place. The high order bit is loaded into the C-bit of the status word and the previous contents of the C-bit are loaded into the low order bit of the destination.

Table 6-3 (Cont)
Single Operand Instructions

Mnemonic/ Instruction Time	OP Code	Operation	Condition Codes	Description
ASR ASRB 3.4 μ s	0062DDD 1062DDD	(dst) \leftarrow (dst) shifted one place to the right.	N: set if the high order bit of the result is set (result $<$ 0); cleared otherwise Z: set if the result = 0; cleared otherwise V: loaded from the exclusive- OR of the N-bit and C-bit (as set by the completion of the shift operation). C: loaded from low order bit of the destination	Shifts all bits of the destination right one place. The high order bit is replicated. The C-bit is loaded from the low order bit of the destination. ASR performs signed division of the destination by two.
ASL ASLB 3.4 μ s	0063DDD 1063DDD	(dst) \leftarrow (dst) shifted one place to the left.	N: set if high order bit of the (result $<$ 0); cleared otherwise Z: set if the result = 0; cleared otherwise V: loaded with the exclusive- OR of the N-bit and C-bit and C-bit (as set by the completion of the shift operation) C: loaded with the high order bit of the destination	Shifts all bits of the destination left one place. The low order bit is loaded with a 0. The C-bit of the status word is loaded from the high order bit of the destination. ASL performs a signed multiplication of the destination by 2 with overflow indication.

Table 6-3 (Cont)
Single Operand Instructions

Mnemonic/ Instruction Time	OP Code	Operation	Condition Codes	Description
JMP 1.0 μ s	0001DD	PC \leftarrow (dst)	Not effected.	JMP provides more flexible program branching than provided with the branch instruction. Control may be transferred to any location in memory (no range limitation) and can be accomplished with the full flexibility of the addressing modes, with the exception of register mode 0. Execution of a jump with mode 0 will cause an illegal instruction condition. (Program control cannot be transferred to a register.) Register deferred mode is legal and will cause program control to be transferred to the address held in the specified register. Note that instructions are word data and must therefore be fetched from an even numbered address. A boundary error trap condition will result when the processor attempts to fetch an instruction from an odd address.
SWAB 4.3 μ s	0003DD	Byte 1/Byte 0 Byte 0/Byte 1	N: set if high order bit of low order byte (bit 7) of result is set, cleared otherwise Z: set if low order byte of result = 0; cleared otherwise V: cleared C: cleared	Exchanges high order byte and low order byte of the destination word (destination must be a word address).

* DD = destination (address mode and register)

† (dst) = destination contents

Table 6-4
Double Operand Instructions

Mnemonic/ Instruction Time	OP Code	Operation	Condition Codes	Description
MOV MOV B 3.7 μ s 3.1 μ s mode 0	01SSDD* 11SSDD	(dst) \leftarrow (src) [†]	N: set if (src) < 0; cleared otherwise Z: set if (src) = 0; cleared otherwise V: cleared C: not effected	Word: Moves the source operand to the destination location. The previous contents of the destination are lost. The source operand is not effected. Byte: Same as MOV. The MOV B to a register (unique among byte instructions) extends the most significant bit of the low order byte (sign extension). Otherwise, MOV B operates on bytes exactly as MOV operates on words.
CMP CMP B 3.7 μ s	02SSDD 12SSDD	(src) - (dst) [in detail, (src) + ~ (dst) + 1]	N: set if result < 0; cleared otherwise Z: set if result = 0; cleared otherwise V: set if there was arithmetic overflow, i.e., operands were of opposite signs and the sign of the destination was the same as the sign of the result; cleared otherwise C: cleared if there was a carry from the most significant bit of the result; set otherwise	Compares the source and destination operands and sets the condition codes, which may then be used for arithmetic and logical conditional branches. Both operands are unaffected. The only action is to set the condition codes. The compare is customarily followed by a conditional branch instruction. Note that unlike the subtract instruction the order of operation is (src) - (dst), not (dst) - (src).

Table 6-4 (Cont)
Double Operand Instructions

Mnemonic/ Instruction Time	OP Code	Operation	Condition Codes	Description
BIT BITB 3.7 μ s	03SSDD 13SSDD	$(src) \wedge (dst)$	N: set if high order bit of result set; cleared otherwise Z: set if result = 0; cleared otherwise V: cleared C: not effected	Performs logical AND comparison of the source and destination operands and modifies condition codes accordingly. Neither the source nor destination operands are effected. The BIT instruction may be used to test whether any of the corresponding bits that are set in the destination are clear in the source.
BIC BICB 3.7 μ s	04SSDD 14SSDD	$(dst) \leftarrow \sim (src) \wedge (dst)$	N: set if high order bit of result set, cleared otherwise Z: set if result = 0; cleared otherwise V: cleared C: not effected	Clears each bit in the destination that corresponds to a set bit in the source. The original contents of the destination are lost. The contents of the source are uneffected.
BIS BISB 3.7 μ s	05SSDD 15SSDD	$(dst) \leftarrow (src) \wedge (dst)$	N: set if high order bit of result set; cleared otherwise Z: set if result = 0; cleared otherwise V: cleared C: not effected	Performs inclusive-OR operation between the source and destination operands and leaves the result at the destination address; i.e., corresponding bits set in the destination. The contents of the destination are lost.
ADD	06SSDD	$(dst) \leftarrow (src) + (dst)$	N: set if result 0; cleared otherwise Z: set if result = 0; cleared otherwise	Adds the source operand to the destination operand and stores the result at the destination address. The original contents of the destination are lost. The contents of the source are not effected. Two's complement addition is performed.

Table 6-4 (Cont)
Double Operand Instructions

Mnemonic/ Instruction Time	OP Code	Operation	Condition Codes	Description
ADD (Cont)			<p>V: set if there was arithmetic overflow as a result of the operation; that is both operands were of the same sign and the result was of the opposite sign; cleared otherwise</p> <p>C: set if there was a carry from the most significant bit of the result; cleared otherwise</p>	
SUB 3.7 μ s	16SSDD	$(dst) \leftarrow (dst) - (src)$ in detail, $(dst) + \sim (src) + 1 (dst)$	<p>N: set if result < 0; cleared otherwise</p> <p>Z: set if result = 0; cleared otherwise</p> <p>V: set if there was arithmetic overflow as a result of the operation, i.e., if operands were of opposite signs and the sign of the source was the same as the sign of the result; cleared otherwise</p> <p>C: cleared if there was a carry from the most significant bit of the result; set otherwise</p>	<p>Subtracts the source operand from the destination operand and leaves the result at the destination address. The original contents of the destination are lost. The contents of the source are not effected. In double precision arithmetic, the C-bit, when set, indicates a borrow.</p>

* SS = source (address mode and register)

† (src) = source contents

Table 6-5
Program Control Instructions

Mnemonic/ Instruction Time	OP Code	Operation	Condition Codes	Description
BR 2.5 μ s	000400 xxx†	PC \leftarrow PC + (2 X offset)	Unaffected	Provides a way of transferring program control within a range of - 128 to +127 words with a one word instruction. It is an unconditional branch.
BNE 1.9 μ s no branch 2.5 μ s branch	001000 xxx	PC \leftarrow PC + (2 X offset) if Z = 0	Unaffected	Tests the state of the Z-bit and causes a branch if the Z-bit is clear. BNE is the complementary operation to BEQ. It is used to test inequality following a CMP, to test that some bits set in the destination were also in the source, following a BIT, and generally, to test that the result of the previous operation was not 0.
BEQ 1.9 μ s no branch 2.5 μ s branch	001400 xxx	PC \leftarrow PC + (2 X offset) if Z = 1	Unaffected	Tests the state of the Z-bit and causes a branch if Z is set. As an example, it is used to test equality following a CMP operation, to test that no bits set in the destination were also set in the source following a BIT operation, and generally, to test that the result of the previous operation was 0.
BGE 1.9 μ s no branch 2.5 μ s branch	002000 xxx	PC \leftarrow PC + (2 X offset) if N v V = 0	Unaffected	Causes a branch if N and V are either both clear or both set. BGE is the complementary operation to BLT. Thus, BGE always causes a branch when it follows an operation that caused addition to two positive numbers. BGE also causes a branch on a 0 result.

Table 6-5 (Cont)
Program Control Instructions

Mnemonic/ Instruction Time	OP Code	Operation	Condition Codes	Description
BLT 1.9 μ s no branch 2.5 μ s branch	002400 xxx	PC \leftarrow PC + (2 X offset) if N V = 1	Unaffected	Causes a branch if the exclusive-OR of the N- and V-bits are 1. Thus, BLT always branches following an operation that added two negative numbers, even if overflow occurred. In particular, BLT always causes a branch if it follows a CMP instruction operating on a negative source and a positive destination (even if overflow occurred). Further, BLT never causes a branch when it follows a CMP instruction operating on a positive source and negative destination. BLT does not cause a branch if the result of the previous operation was 0 (without overflow).
BGT 1.9 μ s no branch 2.5 μ s branch	003000 xxx	PC \leftarrow PC + (2 X offset) if Z v (N ∇ V) = 0	Unaffected	Operation of BGT is similar to BGE, except BGT does not cause a branch on a 0 result.
BLE 1.9 μ s no branch 2.5 μ s branch	003400 xxx	PC \leftarrow PC + (2 X offset) if Z v (N ∇ V) = 1	Unaffected	Operation is similar to BLT but in addition will cause a branch if the result of the previous operation was 0.
BPL 1.9 μ s no branch 2.5 μ s branch	100000 xxx	PC \leftarrow PC + (2 X offset) if N = 0	Unaffected	Tests the state of the N-bit and causes a branch if N is clear. BPL is the complementary operation of BMI.
BMI 1.9 μ s no branch 2.5 μ s branch	100400 xxx	PC \leftarrow PC + (2 X offset) if N = 1	Unaffected	Tests the state of the N-bit and causes a branch if N is set. It is used to test the sign (most significant bit) of the result of the previous operation.

Table 6-5 (Cont)
Program Control Instructions

Mnemonic/ Instruction Time	OP Code	Operation	Condition Codes	Description
BHI 1.9 μ s no branch 2.5 μ s branch	101000 xxx	PC \leftarrow PC + (2X offset) if C = 0	Unaffected	Causes a branch if the previous operation causes neither a carry nor a 0 result. This will happen in comparison (CMP) operations as long as the source has a higher unsigned value than the destination.
BLOS 1.9 μ s no branch 2.5 μ s branch	101400 xxx	PC \leftarrow PC + (2X offset) if C v Z = 1	Unaffected	Causes a branch if the previous operation caused either a carry or a 0 result. BLOS is the complementary operation to BHI. The branch occurs in comparison operations as long as the source is equal to or has a lower unsigned value than the destination. Comparison of unsigned values with the CMP instruction to be tested for "higher or same" and "higher" by a simple test of the C-bit.
BVC 1.9 μ s no branch 2.5 μ s branch	102000 xxx	PC \leftarrow PC + (2X offset) if V = 0	Unaffected	Tests the state of the V-bit and causes a branch if the V-bit is clear. BVC is complementary operation to BVS.
BVS 1.9 μ s no branch 2.5 μ s branch	102400 xxx	PC \leftarrow PC + (2X offset) if V = 1	Unaffected	Tests the state of V-bit (overflow) and causes a branch if the V-bit is set. BVS is used to detect arithmetic overflow in the previous operation.
BCC BHIS 1.9 μ s no branch 2.5 μ s branch	103000 xxx	PC \leftarrow PC + (2X offset) if C = 0	Unaffected	Tests the state of the C-bit and causes a branch if C is clear. BCC is the complementary operation to BCS.
BCS BLO 1.9 μ s no branch 2.5 μ s branch	103400 xxx	PC \leftarrow PC + (2X offset) if C = 1	Unaffected	Tests the state of the C-bit and causes a branch if C is set. It is used to test for a carry in the result of a previous operation.

Table 6-5 (Cont)
Program Control Instruction

Mnemonic/ Instruction Time	OP Code	Operation	Condition Codes	Description
JRS 3.8 μ s	004RDD	(tmp) \leftarrow (dst) (tmp is an inter-processor register) \downarrow (SP) \leftarrow reg (push reg contents onto processor stack) reg \leftarrow PC PC holds location following JSR; this address PC \leftarrow (tmp), now put in (reg)	Unaffected	In execution of the JSR, the old contents of the specified register (the linkage pointer) are automatically pushed onto the processor stack and new linkage information placed in the register. Thus, subroutines nested within subroutines to any depth may all be called with the same linkage register. There is no need either to plan the maximum depth at which any particular subroutine will be called or to include instructions in each routine to save and restore the linkage pointer. Further, since all linkages are saved in a re-entrant manner on the processor stack, execution of a subroutine may be interrupted, and the same subroutine re-entered and executed by an interrupt service routine. Execution of the initial subroutine can then be resumed when other requests are satisfied. This process (called nesting) can proceed to any level.
RTS 3.8 μ s	00020R	PC \leftarrow (reg) (reg) \leftarrow SP \uparrow	Unaffected	JSR PC, dst is a special case of the PDP-11 subroutine call suitable for subroutine calls that transmit parameters. Loads contents of register into PC and pops the top element of the processor stack into the specified register. Return from a non-re-entrant subroutine is typically made through the same register that was used in its call. Thus, a subroutine called with a JSR PC, dst exits with an RTS PC, and a subroutine called with a JSR R5, dst may pick up parameters with addressing modes (R5) +, X (R5), or @X (R5) and finally exit, with an RTS R5.

Table 6-5 (Cont)
Program Control Instructions

Mnemonic/ Instruction Time	OP Code	Operation	Condition Codes	Description
(No mnemonic) 8.2 μ s	000003	\downarrow (SP) \leftarrow PS \downarrow (SP) \leftarrow PC PC \leftarrow (14) PS \leftarrow (16)	N: loaded from trap vector Z: loaded from trap vector V: loaded from trap vector C: loaded from trap vector	Performs a trap sequence with a trap vector address of 14. Used to call debugging aids. The user is cautioned against employing code 000003 in programs run under these debugging aids.
IOT 8.2 μ s	000004	\downarrow (SP) \leftarrow PS \downarrow (SP) \leftarrow PC PC \leftarrow (20) PS \leftarrow (22)	N: loaded from trap vector Z: loaded from trap vector C: loaded from trap vector	Performs a trap sequence with a trap vector address of 20. Used to call the I/O executive routine IOX in the paper-tape software system, and for error reporting in the disk operating system.
EMT 8.2 μ s	104000	\downarrow (SP) \leftarrow PS \downarrow (SP) \leftarrow PC PC \leftarrow (30) PS \leftarrow (32)	N: loaded from trap vector Z: loaded from trap vector V: loaded from trap vector C: loaded from trap vector	All operation codes from 104000 to 104377 are EMT instructions and may be used to transmit information to the emulating routine (e.g., function to be performed). The trap vector for EMT is at address 30; the new central processor status (PS) is taken from the word at address 32.
TRAP 8.2 μ s	104400 to 104777	\downarrow (SP) \leftarrow PS \downarrow (SP) \leftarrow PC PC \leftarrow (34) PS \leftarrow (36)	N: loaded from trap vector Z: loaded from trap vector V: loaded from trap vector C: loaded from trap vector	<p style="text-align: center;">CAUTION</p> EMT is used frequently by DEC system software and is therefore not recommended for general use.
				<p style="text-align: center;">NOTE</p> Operation codes from 104400 to 104777 are TRAP instructions. TRAPs and EMTs are identical in operation, except that the trap vector for TRAP is at address 34.
				Since DEC software makes frequent use of EMT, the TRAP instruction is recommended for general use.

NOTE: Condition Codes are unaffected by these instructions

†xxx = offset, 8 bits (0-7) of instruction format

R = register (linkage pointer)

Table 6-6
Operate Group Instructions

Mnemonic/ Instruction Time	OP Code	Operation	Condition Codes	Description
HALT 1.8 μ s	000000		Not effected	Causes the processor operation to cease. The console is given control of the processor. The console data lights display the address of the HALT instruction plus two. Transfers on the Unibus are terminated immediately. The PC points to the next instruction to be executed. Pressing the CON key on the console causes processor operation to resume. No INIT signal is given.
WAIT 1.8 μ s	000001		Not effected	Provides a way for the processor to relinquish use of the bus while it waits for an external interrupt. Having been given a WAIT command, the processor will not compete for bus by fetching instructions or operands from memory. This permits higher transfer rates between device and memory, since no processor induced latencies will be encountered by bus requests from the device. In WAIT, as in all instructions, the PC points to the next instruction following the WAIT operation. Thus, when an interrupt causes the PC and PS to be pushed onto the stack, the address of the next instruction following the WAIT is saved. The exit from the interrupt routine (i.e., execution of an RTI instruction) will cause resumption of the interrupted process at the instruction following the WAIT.
RTI 4.4 μ s	000002	PC (SP) PSW (SP)	N: loaded from processor stack Z: loaded from processor stack V: loaded from processor stack C: loaded from processor stack	Used to exit from an interrupt or trap service routine. The PC and PSW are restored (popped) from the processor stack. If a trace trap is pending, the first instruction after the RTI will be executed prior to the next T trap.
RESET 20 ms	000005	PC (SP) PSW (SP)	Not effected	Sends INIT on the Unibus for 20 ms. All devices on the Unibus are reset to their state at power-up.

**Table 6-7
Condition Code Operators**

Mnemonic/ Instruction Time	OP Code	Description
CLC	000241	Set and clear condition code bits. Selectable combination of these bits may be cleared or set together. Condition code bits corresponding to bits in the condition code operator (bits 0–3) are modified according to the sense of bit 4, the set/clear bit of the operator; i.e., set the bit specified by bit 0, 1, 2, or 3 if bit 4 is a 1. Clear corresponding bits if bit 4 = 0.
CLZ	000242	
CLN	000244	
CLV	000250	
Set all CCs	000261	
Clear all CCs	000262	
Clear V and C	000264	
No operation	000270	
No operation	000277	
	000257	
2.5 μ s	000243	
	000240	
	000260	

1. Single Operand Group (CLR,CLRB,COM,COMB,INC,INCB,DEC,DECB,NEG,NEGB,ADC,ADCB,SBC,SBCB,TST,TSTB,ROR,RORB,ROL,ROLB,ASR,ASRB,ASL,ASLB,JMP,SWAB)

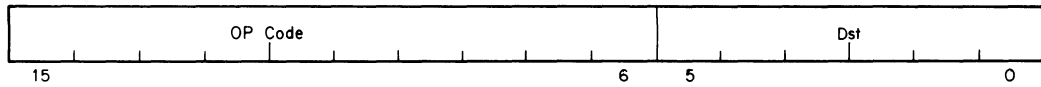

2. Double Operand Group (BIT,BITB,BIC,BICB,BIS,BISB,ADD,SUB)

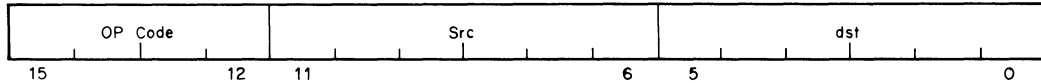

3. Program Control Group

a. Branch (all branch instructions)

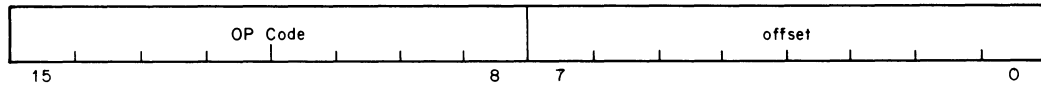

b. Jump To Subroutine (JSR)

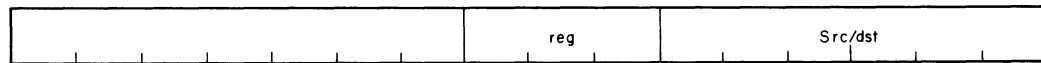

c. Subroutine Return (RTS)

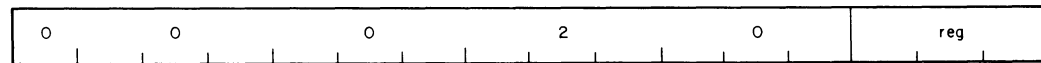

d. Traps (break point, IOT, EMT, TRAP)

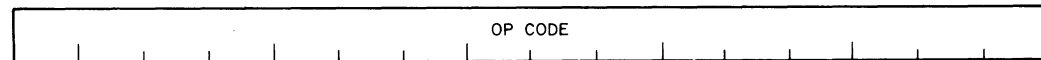

4. Operate Groupe (HALT, WAIT, RTI, RESET)

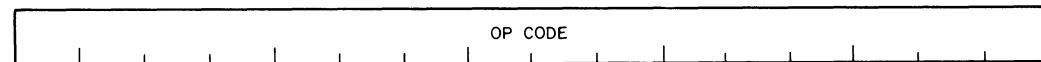

5. Condition Code Operators (all condition code instructions)

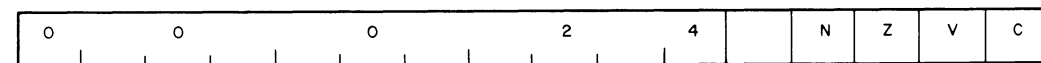

Figure 6-2 PDP-11 Instruction Formats

11-1226

Table 6-8
PDP-11 Differences

	PDP-11/05, PDP-11/10
<p>PDP-11/15, PDP-11/20</p> <p>OPR %R, (R) +/- (R), source operand is %R after autoincrement/autodecrement of DEST register only when source and destination registers are the same.</p> <p>Example: 12700 MOV #100, R0 100 10020 MOV R0, (R0) + 0 HALT</p> <p>After Execution: R0 = 102 LOC100 = 102</p> <p>OPR %R, @(R) /@(R) + uses R after autodecrement/autoincrement as source operand.</p> <p>MOV PC, LOC stores PC of INST +4 in LOC.</p> <p>SWAB does not change V.</p> <p>Program halt displays PC of halt instruction in ADDRESS lights. DATA lights display (RO).</p> <p>Byte ops to the odd byte of the PS cause odd address trap.</p> <p>The RESET instruction clears the RUN light such that program loops that make frequent use of RESET may not appear to be running.</p> <p>Power fail during RESET instruction is not recognized until after the instruction is finished (70 ms). Too late, so don't use RESET. RESET instruction consists of 70 ms pause with INIT occurring during first 20 ms.</p>	<p>OPR %R, (R) +/- R source operand is %R before autoincrement/autodecrement of DEST register whether source or destination registers are the same or not.</p> <p>Example: 12700 MOV #100, R0 100 10020 MOV R0, (R0) + 0 HALT</p> <p>After Execution: R0 = 102 LOC100 = 100 (Note that LOC100 is now 100)</p> <p>OPR %R, @(R) /@(R) + uses R before autodecrement/autoincrement as source operand.</p> <p>MOV PC, LOC stores PC of INST +2 in LOC.</p> <p>Swab clears V.</p> <p>Displays next PC.</p> <p>Byte ops to odd byte of PS do not trap. Not all bits may exist.</p> <p>RESET does not clear the RUN light.</p> <p>Power fail immediately ends the RESET instructions and traps if an INIT is in progress (22 ms). A minimum INIT of 300 ns occurs if the instruction aborted. Power fail during RESET fetch is fatal: no power-down sequence.</p>

Table 6-8 (Cont)
PDP-11 Differences

PDP-11/15, PDP-11/20	PDP-11/05, PDP-11/10
<p>The first instruction in an interrupt service routine is guaranteed to be executed.</p> <p>Sequence of internal processor traps, external interrupts, HALT and WAIT:</p> <p>BUS ERROR Trap Odd Address Data Time Out</p> <p>HALT Instruction for Console Operation</p> <p>TRAP Instructions: Illegal or Reserved Instructions, TRTT, IOT, EMT, TRAP</p> <p>TRACE TRAP: T-bit of processor status</p> <p>OVFL Trap: Stack overflow</p> <p>PWR FAIL Trap: Power down</p> <p>CONSOLE BUS REQUEST: Console operation after HALT switch</p> <p>UNIBUS BUS REQUEST: Peripheral Request, compared with Processor Priority - usually an interrupt occurs.</p> <p>WAIT LOOP: Loop on a WAIT instruction in IR until an interrupt allows exit. A CONSOLE BUS REQUEST returns to this loop after being honored.</p>	<p>The first instruction in an interrupt routine will not be executed if another interrupt occurs at a higher priority level than was assumed by the first interrupt.</p> <p>Sequences:</p> <p>BUS ERROR Traps HALT Instruction TRAP Instructions OVFL Trap PWR Fail Trap UNIBUS BUS REQUESTS CONSOLE STOP (HALT switch) WAIT LOOP</p>

CHAPTER 7

CONSOLE DESCRIPTION

7.1 INTRODUCTION

This chapter provides a general and a detailed description of the console logic. The general description is keyed to the block diagram level, the detailed description covers the theory of operation of the console logic. The function and use of the console controls are discussed in Chapter 4.

7.2 GENERAL DESCRIPTION

The console logic is divided into two sections: address/data register logic, and control switch logic. All the console logic is contained on one printed circuit board, which also contains the switches and indicators.

7.2.1 ADDRESS/DATA Register Logic

During manual console operation, data and addresses are generated by positioning the 16 ADDRESS/DATA Register switches. The switches are 2-position toggle type: the down position grounds the switch and provides a low signal to the processor logic; the up position provides a high signal to the processor logic by connecting the switch to +5V.

The ADDRESS/DATA Register logic samples the 16 bits (address or data) from the B-leg of the processor data section and displays them via the ADDRESS/DATA Register indicators (Figure 7-1). The address/data multiplexer scans the processor 16-bit B-leg signals and provides a serialized output to the Buffer Register. The output of the register consists of 16 signals that are buffered and sent to the 16 ADDRESS/DATA indicators. The buffer has two modes of operation that are controlled by the SHIFT/HOLD signal from the 16-bit synchronous counter. In the shift (scan) mode, serialized data from a scan operation is shifted into the register; this operation takes 16 μ s. At the end of this time, the register enters the hold (display) mode for 240 μ s, during which time the register contents are displayed. This process is continuous and a scan pulse display sequence takes 256 μ s. The information that is scanned (multiplexer input) remains stable for a long time compared to the 256- μ s cycle for the register; therefore, the multiplexer scans relatively stable information that can be displayed.

In addition to supplying the SHIFT/HOLD signal that controls the buffer register, the counter also generates the four scan address signals that select the multiplexer inputs.

The clock provides pulses to clock the counter and Buffer Register. It starts when power is applied and is self-sustaining thereafter.

7.2.2 Control Switch Logic

The six console control switches allow programming functions to be performed manually. They are: load address (LOAD ADRS), examine (EXAM), continue (CONT), deposit (DEP), START, and HALT/ENABLE. The switches provide signals to the processor logic, which actually controls the functions.

A bounce buffer is connected across the output contacts of each switch to eliminate interruptions of the output signal due to contact bounce when the switch is activated. The bounce buffer is a latch constructed of two cross-coupled inverters.

The control switch logic senses a power-up signal (PUP) and PANEL LOCK signal to ensure control switch lockout during the panel lock mode, and to eliminate program interruption after a power interruption with the HALT/ENABLE switch left inadvertently in the HALT position during operation in the panel lock mode.

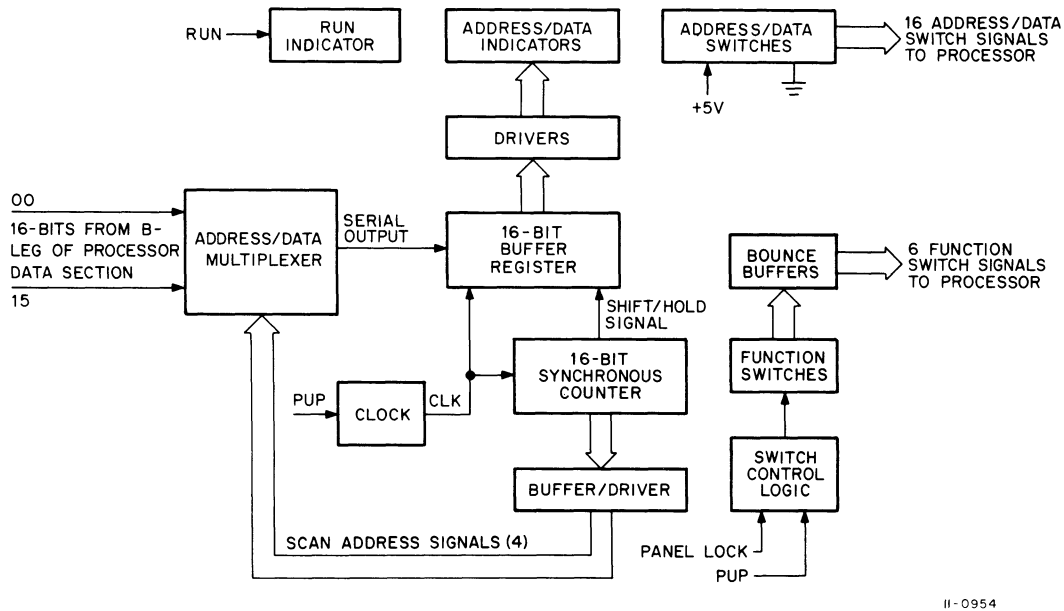

II-0954

Figure 7-1 Console Functional Block Diagram

7.3 DETAILED DESCRIPTION

This paragraph provides a detailed description of the console logic. Each major functional unit is discussed separately and with regard to its interrelation with other functional units.

Both detailed and simplified logic diagrams are used to support the text. The simplified logic diagrams are included in this chapter; however, the detailed logic diagrams are part of the print set that is supplied with each computer. Three drawings are referenced, and they are identified as D-CS-5409766-0-1, sheets 1, 2, and 3. In this discussion, the drawings are referenced by the C-numbers located in the title box and shown below:

- Sheet 1 – Display Buffer and Driver (C-1)
- Sheet 2 – Control Keys (C-3)
- Sheet 3 – Scan Control and Switch Register (C-2)

7.3.1 Multiplexer

The multiplexer, located on the processor M7260 module, scans the 16 bits in the B-leg of the processor data section. The information on these lines can be data bits or address bits. It is serialized in the multiplexer and transmitted over the console cable to the buffer.

The multiplexer is a Type 74150 Data Selector/Multiplexer (1-of-16). It has 16 inputs (E_0 through E_{15}) and a single output. Four SCAN ADRS lines from the counter are the data select lines for the multiplexer: 4 bits give 16 unique combinations. A low strobe signal enables the selected input to the output; however, the signal is inverted at the output.

The four SCAN ADRS lines select the input lines on an equivalent number basis. For example, if the SCAN ADRS lines represent decimal 5, input 5 is selected and enabled to the serial output. The SCAN ADRS lines from the counter are inverted before being sent to the multiplexer. When the counter state is zero (0000), the SCAN ADRS lines indicate 15 (1111) and multiplexer input 15 is selected. This ensures that input 15 is shifted into the proper bit position in the buffer after a scan operation is complete. Table 7-1 shows the relationship between the counter state and SCAN ADRS signals.

Table 7-1
Scan Address Signal Generation

Counter State	SCAN ADRS	MUX Line Scanned
0000 (0)	1111 (15_{10})	15
0001 (1_{10})	1110 (14_{10})	14
0010 (2_{10})	1101 (13_{10})	13
.	.	.
.	.	.
1110 (14_{10})	0001 (1_{10})	1
1111 (15_{10})	0000 (0)	0

7.3.2 Clock

The console clock provides pulses to clock the Counter and Shift Register (drawing C-2). It is a simple oscillator that generates high level clock pulses. Two retriggerable monostable multivibrators (Type 74123) are connected back-to-back to form a simple oscillator (Figure 7-2). The Q output of each is used to trigger the other. The clock starts when power is applied to the processor and is self-sustaining thereafter.

One 74123 IC package (E4) contains two separate and identical units identified as 1 and 2. Output 1Q (pin 13) is connected to input 2A (pin 9) and output 2Q (pin 5) is fed back to input 1A (pin 1). The complementary \bar{Q} outputs are not used, nor are the CLEAR inputs. Input 2B is held high by application of +5V via resistor R18; therefore, unit 2 can be triggered only by a high-to-low level transition at input 2A (see truth table in Figure 7-2). Input 1B (pin 2) is connected to signal PUP from the processor. This signal is low when power is off and is high when power is on. When PUP is low, the clock output is inhibited regardless of the state of input 1A. When PUP goes high during the power-up sequence, it triggers the first high level pulse at output 1Q. The high-to-low level transition of this pulse triggers the first high level pulse at output 2Q (see timing diagram in Figure 7-2). Because both B-inputs are high, the feedback connection (2Q to 1A) allows each unit to trigger on the high-to-low transition at its A input. This produces a continuous string of positive pulses (CLK signal) at output 2Q. Pulse generation is self-sustaining as long as PUP is high.

The counter is clocked on the low-to-high clock pulse transition and the Shift Register is clocked on the high-to-low clock pulse transition. The period between clock pulses allows time for the serial data from the multiplexer to settle down. This is important because the serial data is sent to the Shift Register via a cable connection.

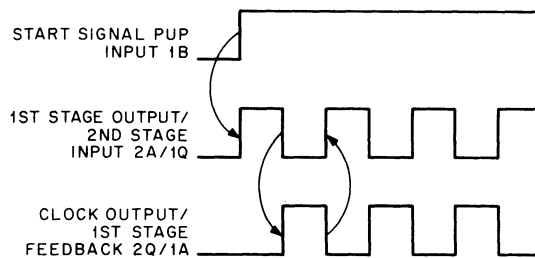
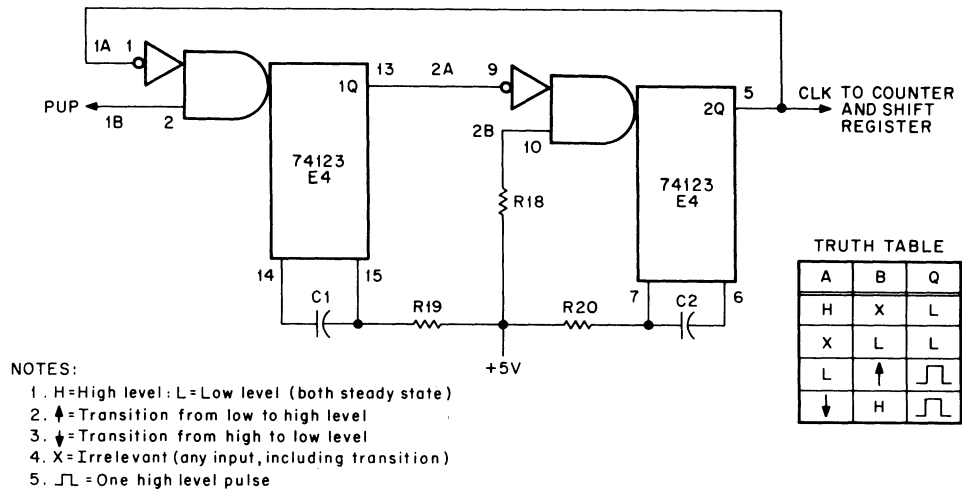

11-0949

Figure 7-2 Console Clock, Schematic and Timing Diagram

7.3.3 Counter

The counter provides four scan address lines that are the data select lines for the data/address multiplexer (drawing C-2). It also provides a control signal (SHIFT DISPLAY) to the Shift Register, which places it in the hold mode.

Two Type 74193 Synchronous 4-Bit Up/Down Counters (E6 and E8) are cascaded to provide an 8-bit counter (Figure 7-3). Cascading is accomplished by connecting the CARRY output (pin 12) of the first counter to the COUNT UP input (pin 5) of the second counter. The counter is used only in the count-up mode; therefore, the COUNT DOWN input is disabled by connecting it to +5V, and the BORROW output is not used.

The preset feature is not used; thus, the LOAD input (pin 11) is disabled by connecting it to +5V. The CLEAR input is not used so that the counter cannot be forced to 0 by an outside signal.

When the clock starts, the counter starts counting through its 256 states. It counts continuously as long as the clock is running.

Two modes of operation occur during one complete counting sequence (256 states) before overflow (all 0s) occurs and the sequence repeats. Output A of the first 4-bit section (E6) is the least significant bit; output D₂ of the second 4-bit section (E8) is the most significant bit. The first section advances from 0 through 15 (16 counts), overflows (goes to 0), and starts over. At overflow, a pulse from the CARRY output of the first section is sent to the COUNT UP input of the second section, which increments the second section by 1. After 16 overflows, the counter is full (all 8 bits are 1s) which represents 255₁₀ or 256 counts. The next clock pulse causes both sections to overflow, which sets the counter to 0 and the sequence repeats.

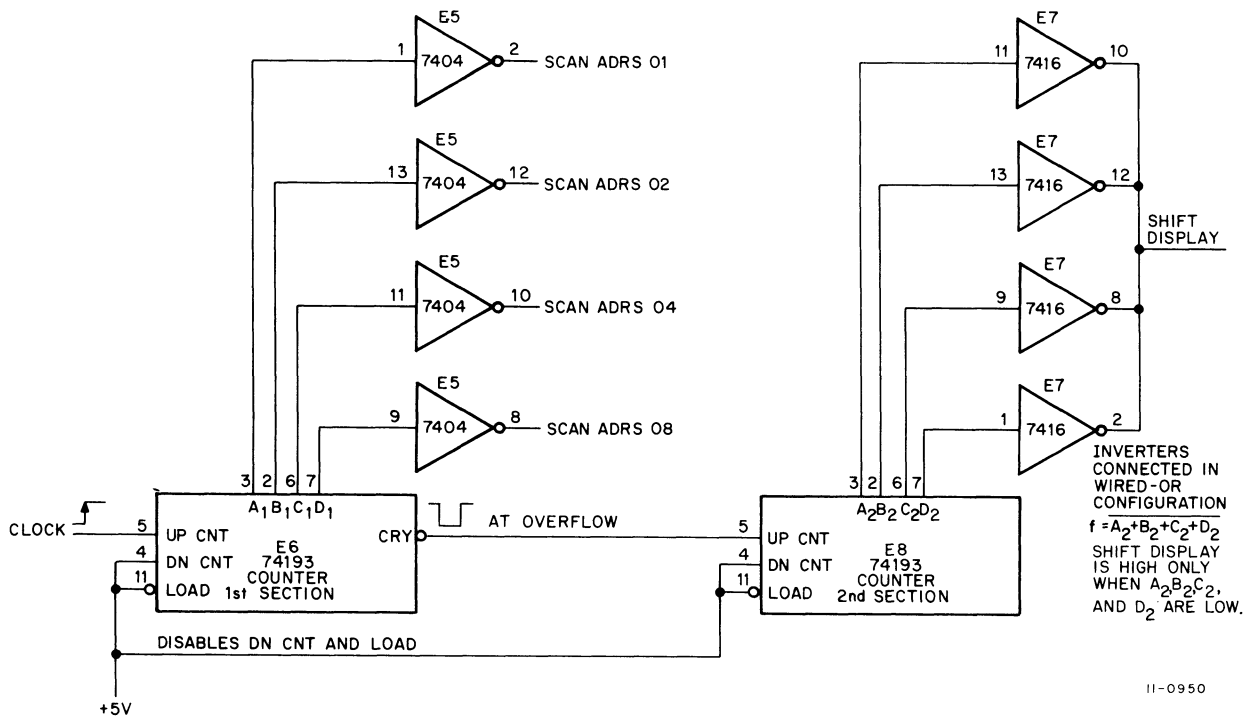

Figure 7-3 Counter, Simplified Logic Diagram

The output of the first counter section is the 4-bit scan address [SCAN ADRS 01 (1) L, 02 (1) L, 04 (1) L, and 08 (1) L]. The lines go to four Type 7404 Inverters (E5) and then to the select inputs of the data/address multiplexer. As the first section of the counter sequences through its 16 states, these lines cause the multiplexer to scan its 16 input lines and send the data serially to the Shift Register. Each of the four outputs of the second counter section goes to a Type 7416 Inverter Driver (E7). The open collectors of these inverters are connected together in a wired-OR configuration. The output is the SHIFT DISPLAY H signal, which is high only when all inverter inputs (E8 counter outputs) are low (0). The SHIFT DISPLAY H signal is a control signal input to the Shift Register. When it is low, the register is in the hold mode; when it is high, the register shifts serial data in to the right. The second counter section is 0 only during states 0 through 15. During this period, SHIFT DISPLAY H is high, and the Shift Register accepts serial data from the multiplexer and shifts it right. This data represents a complete scan of the 16 inputs to the multiplexer that are placed in the Shift Register. At state 16, a 1 is present in the second counter section. From this state, up to and including state 255, one or more 1s are present in the second counter section. The counter states are shown in Table 7-2. During this period, SHIFT DISPLAY H is low, and the Shift Register is in the hold mode. The data is static and is available for display.

A counter state change occurs in approximately $1 \mu\text{s}$; therefore, the scan mode takes $16 \mu\text{s}$ and the hold mode lasts for $240 \mu\text{s}$. During manual console operation, data and addresses are generated by positioning switches. The information on the multiplexer input remains stable for a long time in comparison to the $256 \mu\text{s}$ required for a counter scan/hold cycle. In effect, the multiplexer continually scans relatively stable information that can be displayed as static rather than transient information.

**Table 7-2
Counter States**

Counter State (Decimal)	Counter States								Remarks
	2nd Section				1st Section				
	D	C	B	A	D	C	B	A	
0	0	0	0	0	0	0	0	0	States 0–15 are scan mode. Data is obtained and loaded into Shift Register.
1	0	0	0	0	0	0	0	1	
2	0	0	0	0	0	0	1	0	
3	0	0	0	0	0	0	1	1	
4	0	0	0	0	0	1	0	0	
5	0	0	0	0	0	1	0	1	
.									
.									
15	0	0	0	0	1	1	1	1	
16	0	0	0	1	0	0	0	0	
17	0	0	0	1	0	0	0	1	
18	0	0	0	1	0	0	1	0	
.									
.									
31	0	0	0	1	1	1	1	1	
32	0	0	1	0	0	0	0	0	
.									
.									
239	1	1	1	0	1	1	1	1	
240	1	1	1	1	0	0	0	0	
.									
.									
255	1	1	1	1	1	1	1	1	
0	0	0	0	0	0	0	0	0	

States 0–15 are scan mode. Data is obtained and loaded into Shift Register.

States 16–255 are hold mode. Data is held in Shift Register for display.

← Counter overflow

7.3.4 Display Buffer and Driver

The display buffer and driver logic consists of a 16-bit buffer and 16 inverter drivers for the ADDRESS/DATA Register lights (drawing C-1).

The 16-bit buffer is composed of four Type 8271 4-Bit Registers (E11, E10, E13, and E15). They are connected in a shift-right configuration with a serial data input; the last bit output (DO) of the preceding section is connected to the series data input (DS) of the following section (Figure 7-4). The parallel data inputs are not used. The reset input (RD) is disabled by connecting it to +5V. The LOAD input (pin 10) is connected to ground (logic 0), and the SHIFT input (pin 13) is connected to the SHIFT DISPLAY H signal from the counter. With the LOAD input held low, the operating mode of the buffer is controlled by the SHIFT input. When the SHIFT DISPLAY H signal is high, the buffer accepts data and shifts right; this is the console scan mode. When the SHIFT DISPLAY signal is low, the buffer holds the data; this is the console display mode.

Each Shift Register output signal is sent to a Type 7416 Inverter Driver to illuminate an associated light-emitting diode (LED). The 16 LEDs are the indicators for the ADDRESS/DATA Register display. A high output from the buffer causes the LED to illuminate, which indicates that the associated bit is a logical 1. The final stage of a 7416 inverter has an open collector that is connected to an LED, which in turn is connected to +5V via a current-limiting resistor (Figure 7-5). When the inverter input is low (logical 0 = 0V), no current can flow through the LED because there is no conducting path to ground through the transistor; therefore, the LED is not illuminated. A high (logical 1) inverter input puts a positive voltage on the base of the transistor, which turns it on. Current flows from the +5V source through the resistor, LED, and transistor emitter to ground, which illuminates the LED.

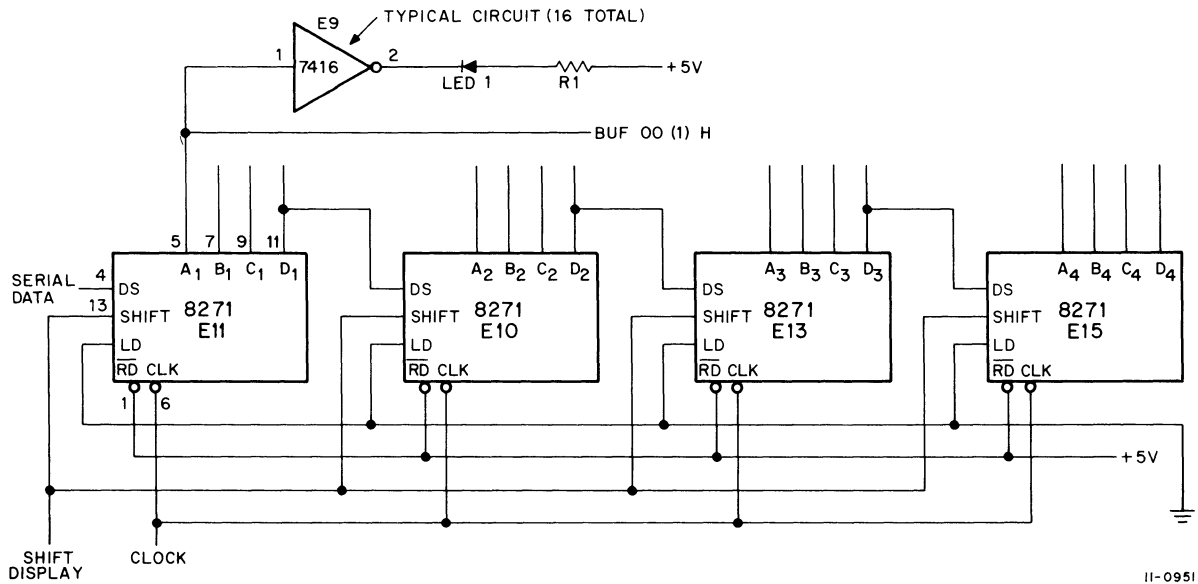

Figure 7-4 Display Buffer and Driver, Simplified Logic Diagram

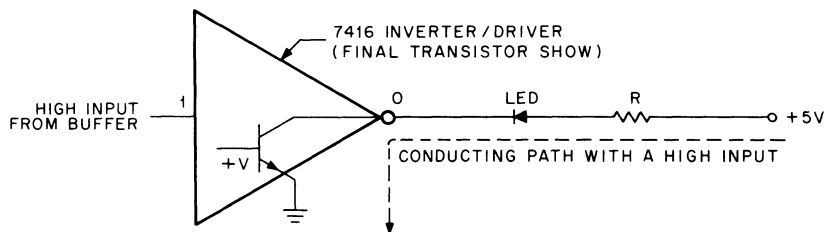

Figure 7-5 LED Driver Circuit

7.3.5 Control Switches and Logic

The console contains six control switches (drawing C-3). The HALT/ENABLE switch is a 2-position toggle type; HALT is the down position and ENABLE is the up position. The other five switches are momentary action type. They are: load address (LOAD ADRS), examine (EXAM), continue (CONT), deposit (DEP) and START. The DEP switch is activated when it is lifted; the others are activated when they are depressed.

A bounce buffer is connected across the output contacts of each switch to eliminate interruptions of the output signal due to contact bounce when the switch is activated. The bounce buffer is a latch constructed of two cross-coupled 7416 inverter buffer/drivers. When the switch is activated, the output signal is latched and any contact bounce, with accompanying signal loss, does not alter the output signal.

For the momentary action switches, the output is asserted low (logical 0) when the switch is activated. For the HALT/ENABLE switch, the output is asserted low when the switch is in the HALT position.

The input of each switch is connected to the output of a 7417 Open-Collector Non-Inverting Buffer. The inputs of all the 7417 buffers are connected to the output of a very simple logic network that detects power on/off and panel lock on/off. Power is sensed by monitoring the power-up signal (PUP L) from the processor. Panel lock is sensed by monitoring the PANEL LOCK signal from the OFF/POWER/PANEL LOCK switch on the console front panel. Panel lock is a mode of operation that disables all console control switches, it prevents inadvertent switch operation from disturbing a running program.

7.3.5.1 Normal Operating Mode – Normal operation is performed with PANEL LOCK off. This discussion is referenced to engineering drawing C-3 and Figure 7-6, which is a simplified logic diagram.

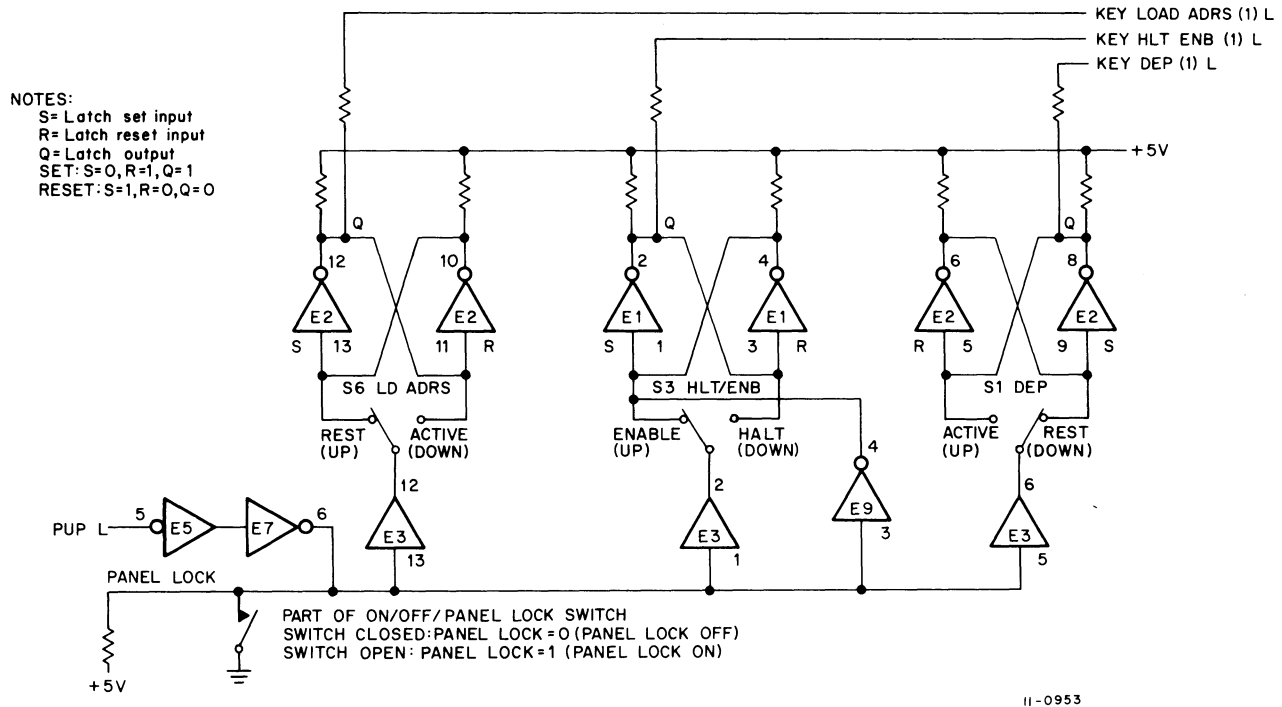

Figure 7-6 Control Switches and Bounce Buffers, Logic Diagram

The switch input logic network is composed of one 7404 Inverter (E5) and one 7416 Open-Collector Inverter (E7). The output of E7 is connected to PANEL LOCK, which is controlled by the key-operated ON/OFF/PANEL LOCK switch on the console panel. When the switch is in the PANEL LOCK position, the panel lock mode is activated and the PANEL LOCK signal is high (logical 1). When the switch is in the ON position, the PANEL LOCK signal is low (logical 0). This is accomplished by grounding the PANEL LOCK signal in this switch position. The output of E7 (pin 6), which represents the state of input PUP L, is connected to the PANEL LOCK signal line. This point is the input to all switch 7417 buffers (E3). It is high only when PUP L and PANEL LOCK are both high.

With PANEL LOCK off, the PANEL LOCK signal is low and the input to each switch is low. [Refer to momentary action switch S6 (LOAD ADRS), which is typical of the five switches of this type.] The set input of the latch is the rest terminal, and the reset input is the active terminal. With S6 in the rest position, a 0 is placed on the set input of the latch (E2 pin 13). The latch is set (S=0, R=1, Q=1) and the output (E2 pin 12) is high, which is the non-asserted state of the switch output [KEY LOAD ADRS (1) L = 1]. With S6 in the active position, a 0 is placed on the reset input of the latch (E2 pin 11). The latch is reset (S=1, R=0, Q=0) and the output (E2 pin 12) is low, which is the asserted state of the switch output [KEY LOAD ADRS (1) L = 0]. Note that the DEP switch (S1) is electrically identical to S6 but its active position is up rather than down.

With the HALT/ENABLE switch (S3) in the ENABLE (up) position, the latch is set and the switch output signal KEY HLT ENB (1) L = 1, which is its non-asserted state. This state allows a program to run. In the HALT (down) position, KEY HLT ENB (1) L = 0 is the asserted state and halts an operating program. Type 7416 Open-Collector Inverter E9 is used for power loss compensation and is described in a subsequent paragraph. In the normal operating mode, it has no effect on the switch operation.

7.3.5.2 Panel Lock Mode – In the panel lock mode, the PANEL LOCK signal is high (+5V via resistor R42). All switch inputs are now high. Panel lock is applied after a program has started in the normal operating mode. All momentary action switches are in the rest position; switch outputs are high (not asserted) because the latches have been set previously (S=0, R=1, Q=1). The HALT/ENABLE switch is in the ENABLE position; the switch output is high (not asserted) because the latch has been set previously (S=0, R=1, Q=1). With respect to the momentary action switches, the high on the switch input has no effect if the switch is moved to the active position, because it puts a 1 on the reset input of the latch whose reset input is already a 1. With respect to the HALT/ENABLE switch, the high on the switch input has no effect if the switch is moved to the HALT position because it puts a 1 on the reset input of the latch whose reset input is already a 1. Remember that the momentary action switch latches had been set (S=0, R=1, Q=1), and the HALT/ENABLE switch latch had also been set.

In this mode of operation, inadvertent switch operation cannot halt or otherwise alter a running program.

7.3.5.3 Power Loss During Operation – The processor contains a power fail circuit that allows the computer to tolerate an ac power loss without adverse effects. If a power loss occurs in the normal operating mode (panel lock off), the switches perform the functions determined by their current positions as soon as the +5V logic supply voltage is reestablished. PANEL LOCK = 0 is the signal that provides normal switch operation in this case.

If a power loss occurs in the panel lock mode, a forcing signal is required to ensure that the latches are driven to the states commensurate with the switch positions before the PANEL LOCK signal is applied again. Without the forcing signal, the latches could be set or reset in a random manner not related to switch position as the +5V logic supply voltage is reestablished.

As ac power is restored, PUP L is forced low for approximately 70 ms. This applies a 0 to the switch inputs to force the latches to the states commensurate with the switch positions: all momentary action switches are not asserted and KEY HLT ENB (1) L is not asserted (HALT/ENABLE switch in ENABLE position). The processor resumes operation and when PUP L goes high again, the panel lock mode is reestablished.

If the HALT/ENABLE switch is inadvertently placed in the HALT position during processor operation in the panel lock mode, the processor does not halt. However, if a power loss occurs with the switch in the HALT position, PUP L going low during the power-up sequence resets the latch and its output, KEY HLT ENB (1) L, is low, which halts the program. When PUP L goes high again and the panel lock mode is reestablished, the 1 on the switch input does not set the latch or eliminate the HALT signal.

Open-collector inverter E9 solves this problem. When PUP L goes high during the power-up sequence, the 1 on the switch input is also inverted by E9 and a 0 is placed on the set input (E1 pin 1) of the latch. The latch is set and its output is not asserted [KEY HLT ENB (1) L = 1], which allows the processor to resume operation even though the switch is in the HALT position.

CHAPTER 8

KD11-B DETAILED DESCRIPTION

8.1 INTRODUCTION

This chapter describes the logic and physical implementation of the KD11-B data path (DP), data path control (DPC), Unibus control, serial communications line (SCL), and the line clock. Extensive use is made of bipolar, medium and large scale integrated circuits in the processor. There are 28 read-only memories (ROMs) used in the KD11-B. Details of the microprogram are described in Chapter 9.

8.2 ROMs AS GENERALIZED GATES

With the increasing availability of inexpensive bipolar ROMs, it is possible to replace rather complex combinational logic structures with one or two 16-pin dual in-line integrated circuits. In the processor, extensive use is made of two different ROM formats. As shown in Figure 8-1, one format stores 256 bits (b), arranged in 32 words of 8 bits each.

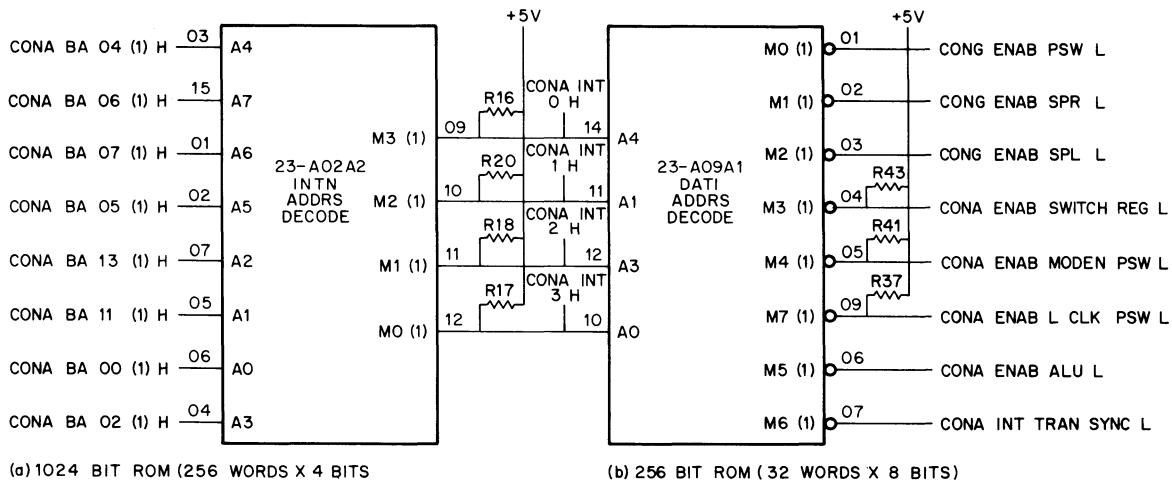

11-1196

Figure 8-1 1024-Bit and 256-Bit ROMs

The other format stores 1024 bits (a), arranged in 256 words of 4 bits each. The 32-word ROM has 5 address lines, 1 output enable line, and 8 outputs. The 256-word ROM has 8 address lines, 2 output enable lines, and 4 outputs. Both devices have open-collector outputs.

Figure 8-2 illustrates the use of a 32 X 8 ROM as a generalized gate. In the example, a 32 X 8 ROM is used as a 5-input priority encoder. The output of the priority encoder follows the following equation:

OUTPUT = V_0 if $I_0 = 1$
 V_1 if $I_0 = 0$ and $I_1 = 1$
 V_2 if $I_0 = I_1 = 0$ and $I_2 = 1$
 .
 .
 V_4 if $I_0 = I_1 = I_2 = I_3 = 0$ and $I_4 = 1$

A similar priority encoder is used in the KD11-B on print CONE where it is necessary to decide which switch function to perform if more than one console switch is depressed.

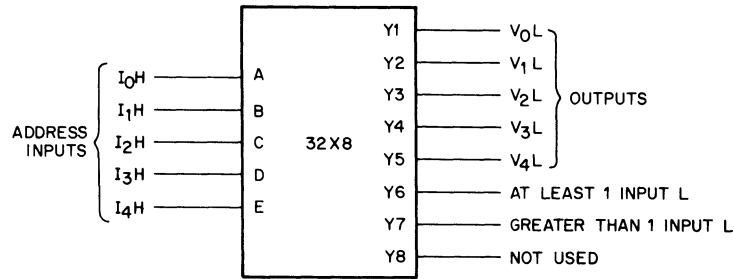

11-1183

1 of 5 Priority Encoder

Truth Table

E	D	C	B	A	Address Octal	Y ₁	Y ₂	Y ₃	Y ₄	Y ₅	Y ₆	Y ₇	Y ₈
0	0	0	0	0	0	0	0	0	0	0	0	0	0
0	0	0	0	1	1	1	0	0	0	0	1	0	0
0	0	0	1	0	2	0	1	0	0	0	1	0	0
0	0	0	1	1	3	0	1	0	0	0	1	1	0
					⋮								
0	0	1	1	1	7	0	0	1	0	0	1	1	0
					⋮								
0	1	1	1	1	17	0	0	0	1	0	1	1	0
					⋮								
1	0	1	1	1	27	0	0	0	0	1	1	1	0
					⋮								
1	1	1	1	1	37	0	0	0	0	1	1	1	0

Figure 8-2 32 X 8 ROM used as Generalized Gate

Many situations arise in which five or fewer input conditions result in combinations of eight or fewer output conditions where a 32×8 ROM is used for implementing the function. Similar applications apply to 256×4 ROMs. For example, the KD11-B uses one 256×4 ROM to test all of the PDP-11 conditional branch instructions against the C, N, V, and Z condition code bits. The branch decode ROM may be found on print DPG in position E059.

8.3 KD11-B DATA PATH, SIMPLIFIED DESCRIPTION

Figure 8-3 contains a simplified diagram of the KD11-B data path. The heart of the DP is an arithmetic-logic unit (ALU), which is capable of performing 16 Boolean operations and 16 different arithmetic operations on two 16-bit binary variables. The inputs to the ALU are storage registers on the A-leg input and the B-leg input. The output of the ALU feeds into a switch that is capable of introducing external data into the DP from the Unibus. The output of the switch feeds back into the Unibus.

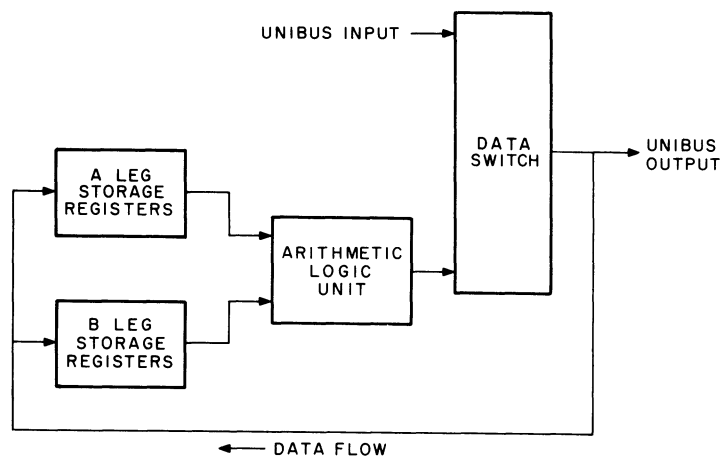

11-1195

Figure 8-3 KD11-B Simplified Data Path Block Diagram

8.3.1 Data Path (DP) Detailed Description

Figure 8-4 is a detailed block diagram of the KD11-B DP. The logic for all elements of the DP shown in Figure 8-4, with the exception of the Bus Address Register and associated Unibus drivers, is found in prints DPA through DPH1. It is important to recognize that this DP consists of a number of interconnected registers that are capable, when properly controlled, of executing the PDP-11 instruction set defined in Chapter 6.

8.3.2 DP Data Polarities

It is useful to note the data polarity at various places in the processor. There are two signal levels used in the KD11-B. A high signal is represented by a voltage of +3V to +5V. A low signal is represented by a voltage between 0V and 0.4V. Positive and negative data polarities are defined as follows:

Negative Data Polarity: Logic 1 = Low Signal = 0-0.4V
 Logic 0 = High Signal = 3-5V

Positive Data Polarity: Logic 1 = High Signal = 3-5V
 Logic 0 = Low Signal = 0-0.4V

Data polarity is negative on the Unibus and within the dotted lines surrounding the ALU as shown in Figure 8-4. Throughout the remainder of the processor the data polarity is generally positive. In the KD11-B print set, the polarity of the asserted logic signal is given. For example, the signal DPF LOAD IR L is asserted, true, or logic 1, when it is at 0V (low signal).

8.3.3 Data Path Control (DPC)

The DPC is shown in Figure 8-4 at the left side of the drawing. All functions performed by the processor, including instruction interpretation, trap handling, and Switch Register (SR) function execution, depend upon the contents of the control store (CS). For each PDP-11 action performed by the KD11-B, the DPC executes a sequence of microsteps stored in the CS.

The microprogram contained in the CS consists of a series of microroutines which, when executed in the proper sequence, enable the KD11-B to perform as a PDP-11 processor. Details of the microprogram are described in Chapter 9.

The CS consists of ten 256×4 bipolar ROMs, shown on prints CONF and CONG. The outputs of the ROMs are used to control the registers and arithmetic elements in the DP. The current control step (microstep) is stored in a microprogram counter (MPC). The MPC is an 8-bit latch that is loaded at intervals of approximately 300 ns with a number generated by the output of the NXT field of the CS, wire-ORed with the outputs of the microbranch network.

8.3.4 A-Multiplexer

The A-Multiplexer (AMUX) is a 2-word, 16-bit multiplexer composed of four Type 8266 2-Input, 4-Bit Digital Multiplexers. The AMUX representation is contained in four logic prints as shown below.

AMUX	
Designation	Print
E009	DPA
E011	DPB
E013	DPC
E015	DPD

The A-word input to the AMUX is the output of the ALU, and the B-word input consists of the Unibus data lines D (15:00). These data signals are taken from the Unibus via four Type 380 Quad 2-Input NOR Gates (called bus receivers). The receiver designations and locations are listed below.

Receiver Designation	Unibus Data Bits	Print
E001	BUS D00-D03	DPA
E003	BUS D04-D07	DPB
E005	BUS D08-D11	DPC
E007	BUS D12-D15	DPD

The AMUX A-input is inverting and the B-input is non-inverting. Word selection is based on the state of select signal inputs S0 and S1 as shown in the following truth table.

Select Signals		Output
S1	S0	f3, f2, f1, f0
L	L	\overline{B}
L	H	A
H	L	B
H	H	1

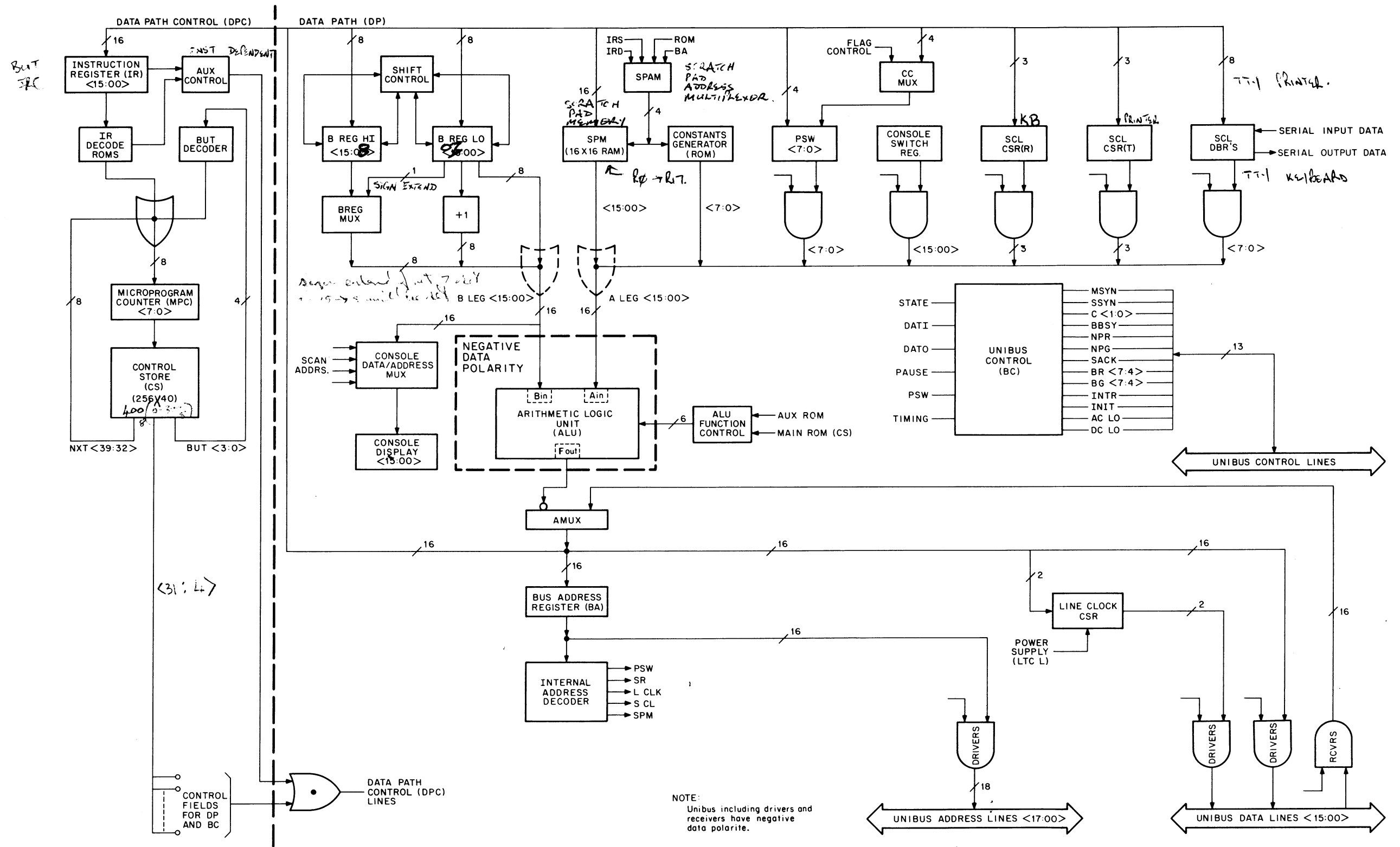

Figure 8-4 KD11-B Detailed Block Diagram

Select signal S0 is CONA ENAB ALU H and S1 is DPA RUN GND L. Signal DPA RUN GND L is connected to ground so it is always low; therefore, signal CONA ENAB ALU H controls the selection of the input. When it is low, the B-input is selected, and when it is high, the A-input is selected.

The 16-bit output of the AMUX is sent to several places as shown below.

Destination	Print
Bus Address Register	CONA
Unibus Drivers	DPA-DPD
Instruction Register	DPF
B-Register	DPA-DPD
Scratch Pad Memory	DPA-DPD
PSW Logic	DPE
SCL Control Logic	DPH
Line Clock	CONI

8.3.5 Arithmetic Logic Unit (ALU)

The arithmetic logic unit (ALU) is the heart of the data path logic. It performs 16 Boolean operations and 16 arithmetic operations on two 16-bit words. Not all of these arithmetic and logic operations are in the KD11-B; Table 9-1 lists the operations that are used. The truth table for the 74181 ALU (Appendix A) shows all the operations that are available.

The ALU is composed of four Type 74181 Arithmetic Logic Unit/Function Generators and one Type 74182 Look-Ahead Carry Generator. The symbolic representation of the ALU is contained on four logic prints as shown below.

Device	Component Designation	Print
74181	E018	DPA
74181	E019	DPB
74181	E020	DPC
74181	E022	DPD
74182	E032	Sections shown on prints DPA, DPB, DPC, and DPD.

Figures 8-5 and 8-6 show the signal and pin designations for the 74181 and 74182, respectively.

For clarity, a detailed block diagram of the ALU is shown in Figure 8-7. The 16-bit A-word input is fed by ALEG (15:00) and the 16-bit B-word input is fed by BLEG (15:00). Each leg is driven by several sources that are connected in a wired-OR configuration. The ALEG sources are: scratch pad memory, constants generator, processor status word logic, console Switch Register, and serial communications line. The BLEG sources are: B register, sign extension logic and +1 logic. Each of these sources is discussed in subsequent paragraphs. The 16-bit ALU output is sent to the A-word input of the AMUX. The AMUX is a 2-word, 16-bit multiplexer composed of four Type 8266 2-Input, 4-Bit Digital Multiplexers. The source of the B-word input to the AMUX is Unibus data bits D (15:00).

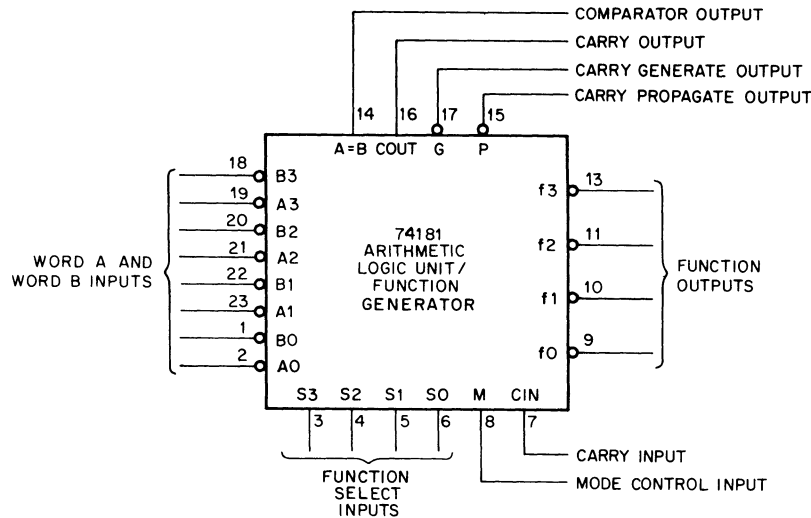

Figure 8-5 74181 Pin and Signal Designations

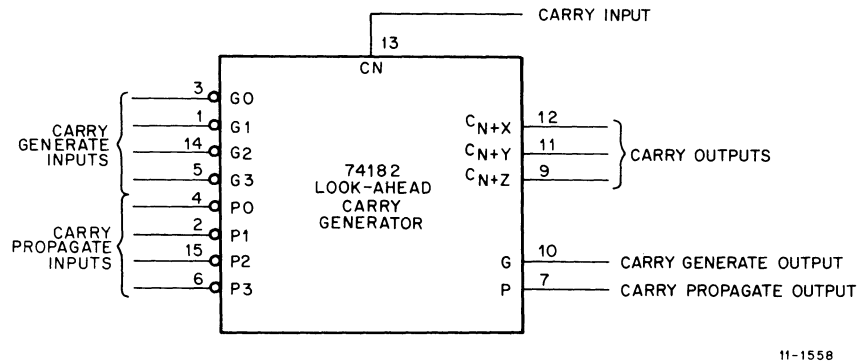

Figure 8-6 74182 Pin and Signal Designations

The ALU is controlled by six input signals (Table 8-1) that select the mode (logic or arithmetic) and the desired function. All control bit combinations versus functions are listed in the 74181 truth table in Appendix A. The primary source for the control signals is the control store logic (print CONF). A wire-ORed connection allows the control signals to also be obtained from the auxiliary ALU control (print DPF) and the IR decoding logic (print DPG). The four function select signals (CONF ALU S0 L-S3 L) are buffered and inverted by Type 7437 NAND Buffers (print DPA) before they are sent to the ALU select inputs. After buffering, they are identified as DPA ALU S0 H-S3 H. Mode signal CONF ALU MODE H is sent directly to the ALU. The carry input signal (CONF CIN H) is sent to one input of exclusive-OR gate E081 (print DPA). The output of this gate is signal DPA ALU CIN 00 H and is sent to the carry inputs of both the 74181 ALU and 74182 carry generators. This signal is also controlled by signals DPF COP L and DPE COUT (1) L. They are inputs to NOR gate E080 which supplies the other input to exclusive-OR gate E081. Signal DPF COP L is an output of E061 SOP AUX CTL ROM 23-A03A1 (print DPF) in the auxiliary ALU control logic. Signal DPE COUT (1) L is an output of E052 COUT flip-flop (print DPE) in the PSW logic.

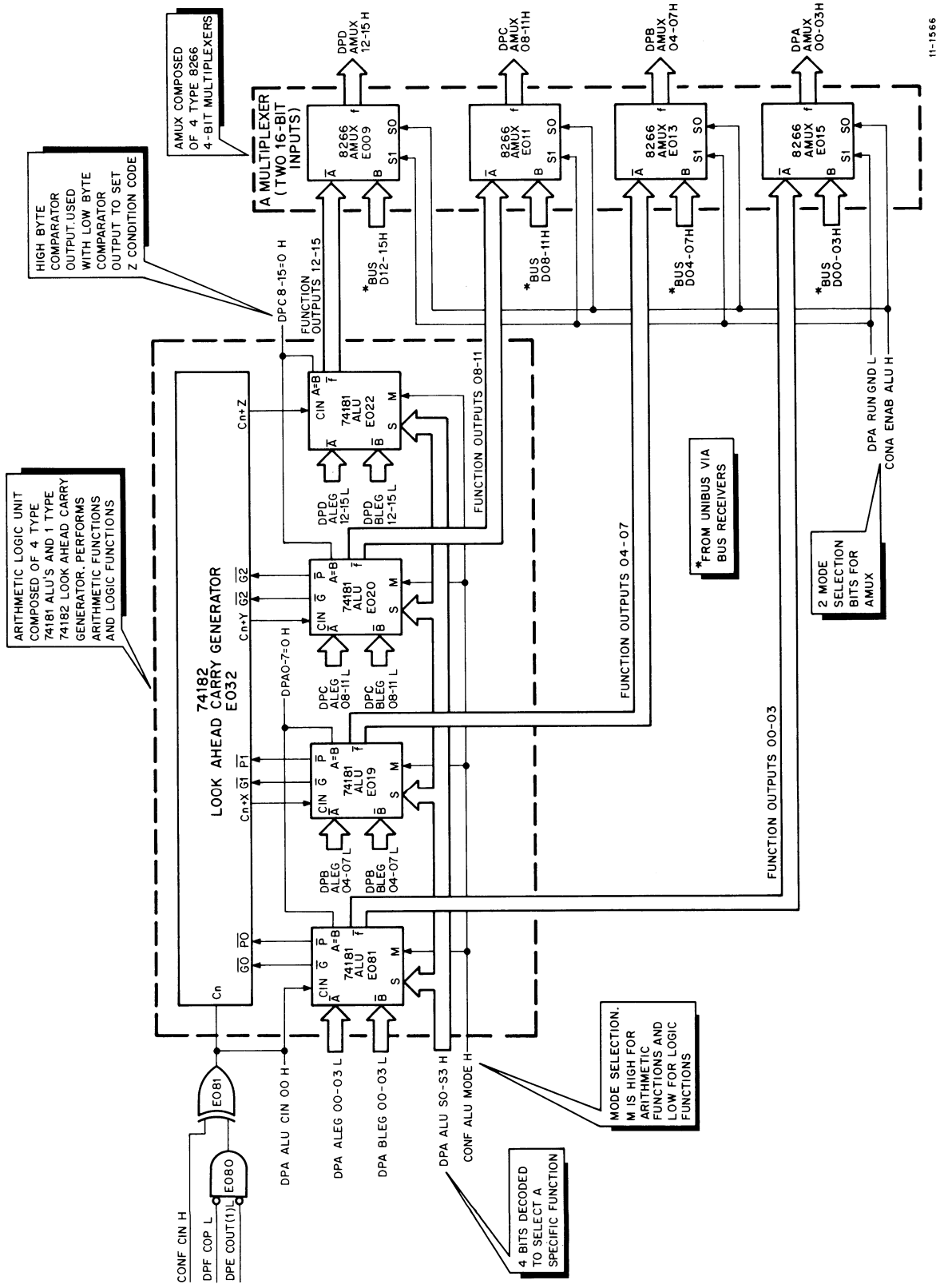

Figure 8-7 Arithmetic Logic Unit Block Diagram

**Table 8-1
ALU Control Signals**

	Signal Source				
	Name	Number	Designation	Print	
	Control Store	ROM23-A11A2	E104	CONF	
	Control Store	ROM23-A06A2	E094	CONF	
	DOP Aux Cont	ROM23-A02A1	E053	DPF	
	SOP Aux Cont	ROM23-A03A1	E061	DPF	
	IR Decode	ROM23-A05A1	E066	DPG	
Control Signal					
CONF ALUS3 H	X		X	X	
CONF ALUS2 H	X		X	X	X
CONF ALUS1 H	X		X	X	
CONF ALUS0 H	X		X	X	X
CONF ALU MODE H		X	X	X	
CONF CIN H		X	X	X	

The A-B terminal of each 74181 ALU is an open-collector comparator output that is high when the input words are equal and the ALU is in the subtract mode. These outputs are wire-ANDed for each data byte to generate equality signals that are used in forming the Z condition code. Signal DPA 0-7=0 H indicates that the inputs to the low data byte are equal to zero. Signal DPA 8-15=0 H indicates that the inputs to the high data byte are equal to zero.

8.3.6 B Register

8.3.6.1 Functional Description – The B register (BREG) is the only storage register in the B-leg of the ALU. The BREG is used as a general purpose register to store the results of any operation that requires data to be read from the SPM. It is used as a shift-left/shift-right register to perform rotate, shift, and byte instructions.

The BREG output is attached to additional logic to permit its lower byte to be sign-extended during execution of byte and branch instructions. Logic is also provided to place the constant +1 on the B-leg. This operation is used in the process of incrementing or decrementing the general registers by 2. This discussion covers the BREG and the additional logic.

The BREG consists of four Type 74194 4-Bit Bidirectional Universal Shift Registers. The register designations and locations are listed below.

74194	
Designation	Print
E044	DPA
E045	DPB
E035	DPC
E038	DPD

The additional logic required for the sign extension and +1 operations is listed below.

Device	Component Designation	Print
74H01	E036 (4)	DPA
74H01	E087	DPA
7404	E073	DPA
7400	E037 (4)	DPB
74S158	E039	DPC
74S158	E040	DPD

For clarity, a simplified logic diagram of the BREG and associated logic is shown in Figure 8-8. The inputs to the BREG consist of the 16 bits from the AMUX. They are identified as:

DPA AMUX 00 H - 03 H
 DPB AMUX 04 H - 07 H
 DPC AMUX 08 H - 11 H
 DPD AMUX 12 H - 15 H

The corresponding BREG outputs are:

DPA BREG 00 (1) H - 03 (1) H
 DPB BREG 04 (1) H - 07 (1) H
 DPC BREG 08 (1) H - 11 (1) H
 DPD BREG 12 (1) H - 15 (1) H

The BREG is clocked by DPA PROC CLOCK L, which is processor clock signal CONJ PROC CLOCK H that has been buffered and inverted by gate E083 pin 03 (print DPA).

The type of operation performed by the BREG is determined by the states of mode control inputs S1 and S0 as shown below.

Mode Control		Operation
S1	S0	
H	H	Parallel Load
L	H	Shift Right (towards LSB)
H	L	Shift Left (towards MSB)
L	L	Hold (clock inhibited)

The BREG is loaded when both mode control inputs (S1 and S0) are high. These inputs are selected by control store field BRG (CS word bits 04 and 05). The signals are: CONG B MODE 01 H (bit 04) that is sent to input S1; and CONG B MODE 00 H (bit 05) that is sent to input S0. Shift-right, shift-left, and hold operations are also controlled by the BRG field (see CS word format in drawing D-CS-M7261-0-1, sheet 13). The shift-right (SR) and shift-left (SL) inputs are the serial data inputs that are used only during shifting operations. They are discussed in subsequent paragraphs.

The eight bits that constitute the low byte of the BREG are sent to NAND gates whose outputs are sent to the B-word input of the ALU. Bits DPA BREG 00 (1) H-03 (1) H are connected to Type 74H01 High Speed NAND Gates which have open-collector outputs. An open-collector gate is used because the +1 logic is wire-ORed to bit BREG 00 (1) H. Bits DPB BREG 04 (1) H-07 (1) H are connected to 7400 NAND gates. All eight bits are enabled by signal CONG BBOT H which is one of two bits of the B-leg control field of the control store word. It is generated by CS ROM E106 (print CONG).

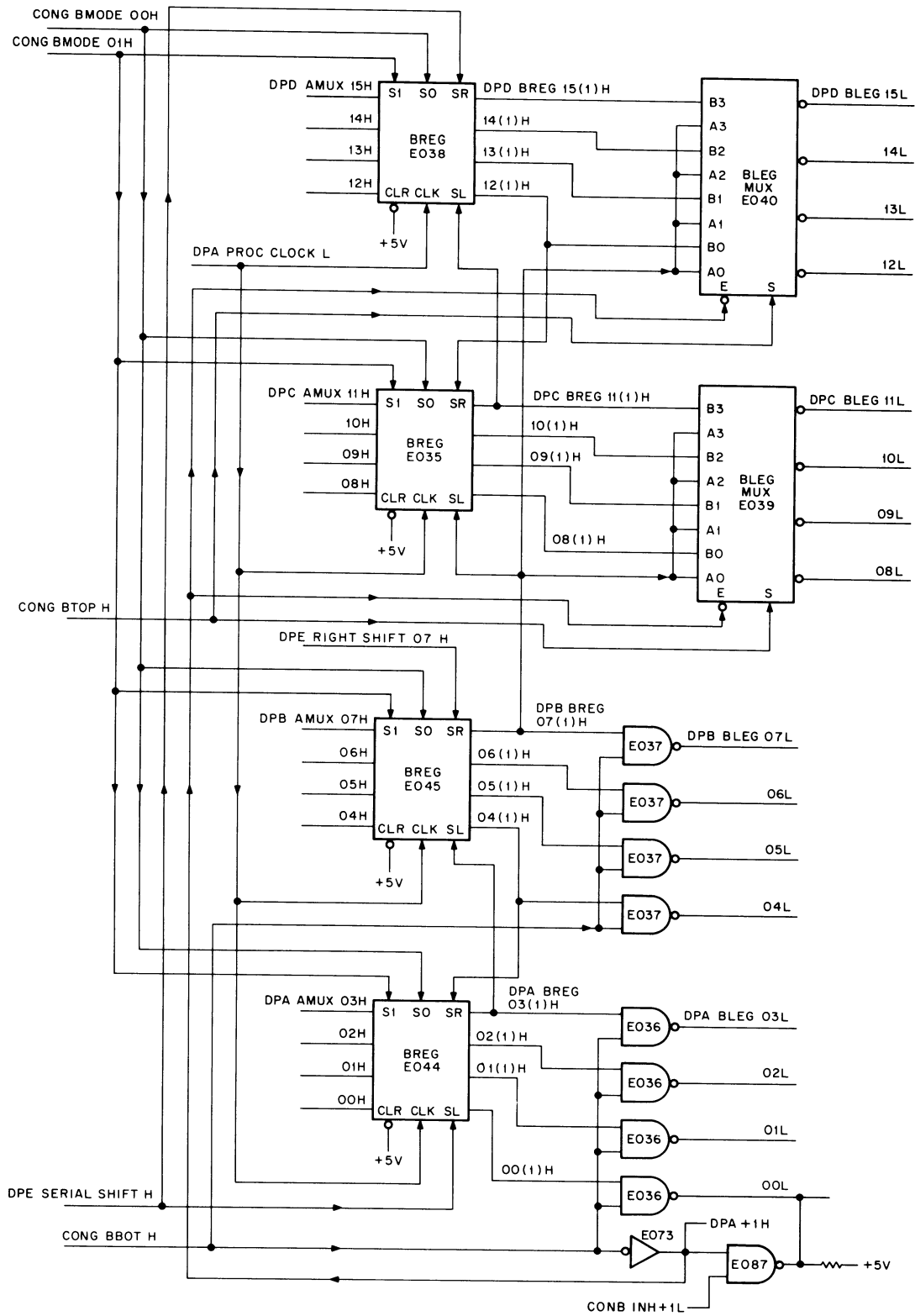

11-1564

Figure 8-8 B Register and Output Logic

The eight bits that constitute the high byte of the BREG are sent to the B-word inputs of the BLEG MUX. The A-word inputs of the BLEG MUX are connected in common to DPB BREG 07 (1) H. The BLEG MUX is composed of two Type 74S158 2-line-to-1-Line Multiplexers. Input word selection is controlled by the select (S) input when the enable (E) input is asserted low as shown below.

Enable (E) Input	Select (S) Input	Output
H	X	H
L	L	A-word
L	H	B-word

The select (S) signal is CONG BTOP H, which is the other bit of the B-leg control field of the control store word. It is generated by CS ROM E095. The enable (E) signal is DPA+1 H from the +1 logic.

The +1 logic consists of inverter E073 and NAND gate E087. When activated, the output of E087 puts a +1 in bit DPA BREG 00 (1) H via a wired-OR connection with the output of the NAND gate associated with this bit from the BREG.

8.3.6.2 BLEG Operations That Provide Input to the ALU – The following discussion covers the three operating modes of the BLEG that provide input data to the ALU. The modes are: BREG unmodified, BREG sign extended, and generation of the constant +1. The output of the BREG is gated onto the BLEG in a manner dictated by the BLEG mode of operation. The circuits involved are the BLEG MUX, +1 logic, and gates E036 and E037 on the outputs of BREG bits 00-07. The discussion is not concerned with the operation of the BREG.

Control of the BLEG operating mode is provided by control store field BLG. This field is physically split in the CS word as shown in Table 8-2.

**Table 8-2
Control Store Signals for BLEG Operations**

Control Store		ROM No.	Output Signal	
Bit	Field		Name	Function
14	BTP	E095	CONG BTOP H	Controls BREG output bits 08–15 (high byte)
16	BBT	E106	CONG BBOT H	Controls BREG output bits 00–07 (low byte)

The following truth table shows the states of CS bits 14 and 16 for the three BLEG modes.

Bit 16 BBT	Bit 14 BTP	BLEG Mode
H	H	BREG Unmodified
H	L	Sign Extend BREG
L	L	Generate Constant +1

In the BREG unmodified mode, it is desired to place the unmodified contents of the BREG on the BLEG. Control store field BLG makes both CONG BTOP H and CONG BBOT H high. Signal CONG BBOT H enables the low byte of the BREG onto the BLEG via gates E036 and E037. Signal CONG BBOT H is inverted by E073 and is identified as DPA +1 H. It is the enabling signal for the BLEG MUX (E039 and E040). In this case, it is low and enables the BLEG MUX. The select (S) signal for the BLEG MUX is CONG BTOP H, which is high. This selects the B-word input of the BLEG MUX which is the high byte of the BREG output. Thus, the 16-bit output of the BREG is transferred to the BLEG unmodified.

In the BREG sign-extended mode, it is desired to place the unmodified low byte of the BREG on the BLEG and sign extend the high byte, which makes bits 08-15 the same as bit 07. The sign-extended high byte is also placed on the BLEG. Control store field BLG makes CONG BBOT H high and CONG BTOP H low. Signal CONG BBOT H enables the low byte of the BREG onto the BLEG via gates E036 and E037.

Bit 07 [DPB BREG 07 (1) H] from the BREG is sent to all eight A-inputs of the BLEG MUX. The BLEG MUX is enabled by DPA +1 H which is low. Select signal CONG BTOP H is low which selects the A-word of the BLEG MUX. This is the high byte of the B-leg but all eight bits are identical and equal to the state of DPB BREG 07 (1) H. The sign of bit 07 is extended to bits 08-15 and these bits, along with unmodified bits 00-07, are transferred to the B-leg.

In the +1 operation, it is desired to place the constant +1 on the BLEG. The constant +1 is placed in the LSB position (bit 00) and all other bits (01-15) are forced to 0. Control store field BLG makes CONG BBOT H and CONG BTOP H both low. Signal CONG BBOT H disables the E036 and E037 gates, which drives BLEG bits 00-07 high. Signal CONG BBOT H is also inverted by E073 to produce DPA +1 H, which is high. Signal CONB INH +1 L controls the activation of the +1 logic. It is high and is ANDed with DPA +1 H to produce a low at the output of NAND gate E087. This output is wire-ORed with the E036 NAND gate associated with bit 00. This action pulls the wire-ORed connection low, which makes bit 00 low. Bits 01-07 remain high. Signal DPA +1 H is high, so it disables the BLEG MUX and drives all its outputs high (bits 08-15). This operation places the constant +1 onto the BLEG.

The BLEG is the input to the B-word of the ALU that uses negative logic. The +1 operation can be readily seen by looking at the BLEG bits with respect to their logical states as follows:

BLEG 00 = Low = Logical 1
BLEG 01-15 = High = Logical 0

8.3.6.3 BREG Shifting Operations – The BREG is used as a left/right shift register to perform rotate, shift, and odd byte instructions. The following discussion covers the shifting process and generation of the serial shift input for the ASL, ASR, ROL, and ROR instructions. An explanation of the BREG operation during the performance of byte instructions is discussed separately.

The key to this discussion is the symbolic representation of the bit structure of the BREG as shown in Figure 8-9. Each of the four 74194 Shift Registers that make up the BREG has a shift-left (SL) serial input and a shift-right (SR) serial input. The SL input is connected to the lowest order bit and the SR input is connected to the highest order bit. The four devices are interconnected to provide shift-left and shift-right paths for the 16-bit BREG. For clarity, the parallel inputs and outputs are not shown.

Mode control signals CONG BMODE 00 H and CONG BMODE 01 H select a shift-left or shift-right operation. In shifting operations that deal with instructions ASL, ASR, ROL, and ROR, the same source is used for serial input data for a shift left or a shift right.

The SL serial input goes to BREG bit 00 and the SR serial input goes to BREG bit 15. When SL or SR is enabled, the other input is disabled. The signal name for the serial data input is DPE SERIAL SHFT H which is the f_1 output of ROT MUX 1 E048 (print DPE). Depending on the instruction being processed, DPE SERIAL SHFT H can load the appropriate BREG serial input with a 0 (for ASL), bit 15 of the BREG output (for ASR), or the C-bit (for ROL and ROR).

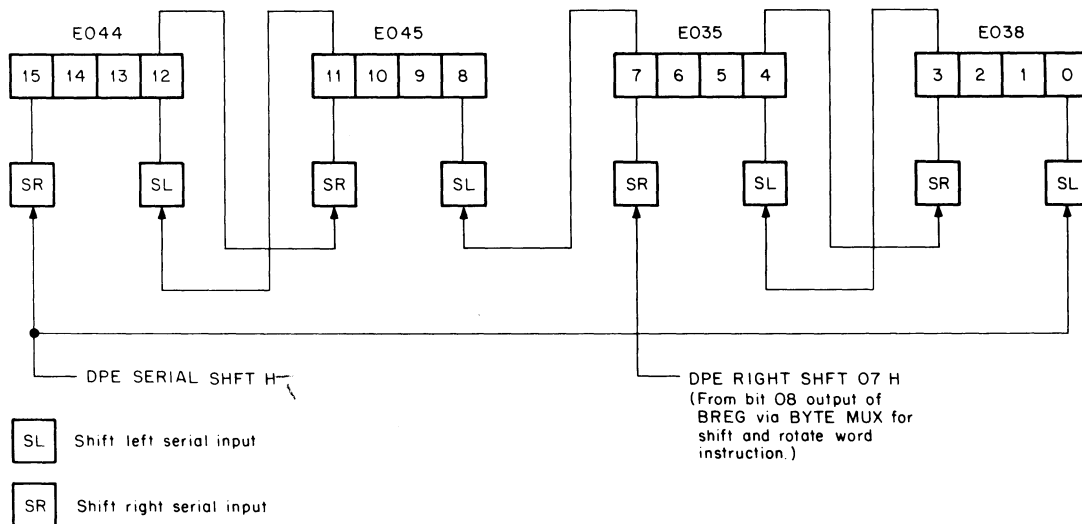

B Register Bit Structure

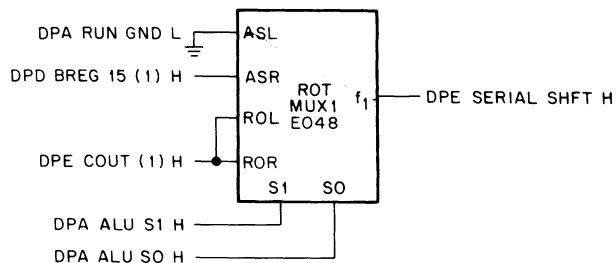

TRUTH TABLE

S1	S0	Funct. (f ₁)
L	L	ROR
L	H	ASR
H	L	ROL
H	H	ASL

Generation of DPE SERIAL SHFT H

11-1567

Instruction	Value of DPE SERIAL SHFT H	Remarks
ASL	DPA RUN GND L	0 to BREG bit 0 via SL input
ASR	DPD BREG 15 (1) H	Bit 15 of BREG output to bit 15 of BREG via SR input
ROL	DPE COUT (1) H	C bit to BREG bit 0 via SL input
ROR	DPE COUT (1) H	C bit to BREG bit 15 via SR input

Figure 8-9 B Register Shift Signal Inputs

The values of DPE SERIAL SHFT H and the truth table for the ROT MUX 1 are shown in Figure 8-9.

This register handles byte shifting also as required by instructions ASLB, ASRB, ROLB, and RORB. Signal DPE RIGHT SHFT 07 H is used as a serial right (SR) input to bit 07 to handle replication of bit 07 for an ASRB instruction and to load the previous contents of the C-bit for an RORB instruction. This signal is also required to perform the word shifting for instructions ASR and ROR because there is no direct connection between bits 08 and 07 for a shift-right operation. Signal DPE RIGHT SHFT 07 H is generated by BYTE MUX E047 and it represents BREG output bit 08 (DPC BREG 08 H) during word instructions ASR and ROR.

The shifting requirements for the ASL, ASR, ROL, and ROR instructions are described briefly below.

Arithmetic Shift Left (ASL) – Shifts all bits left one place. Bit 0 loaded with a 0.

The BREG is shifted left one place. ROT MUX 1 selects ASL input (DPA RUN GND L) which is logical 0 because it is connected to ground. DPE SERIAL SHFT H = 0 and is loaded into BREG bit 00 via the SL input.

Arithmetic Shift Right (ASR) – Shifts all bits right one place. Bit 15 is loaded with BREG output bit 15.

The BREG is shifted right one place. ROT MUX 1 selects ASR input [DPD BREG 15 (1) H], which is output bit 15 of the BREG. DPE SERIAL SHFT H equals the bit 15 output of the BREG and is loaded into BREG bit 15 via the SR input. This is replication of bit 15. DPE RIGHT SHFT 07 H equals the bit 08 output of the BREG and is loaded into BREG bit 07 via the SR input to provide the connection from bit 08 to bit 07.

Rotate Left (ROL) – Rotates all bits left one place. Bit 00 loaded with C-bit.

The BREG is shifted left one place. ROT MUX 1 selects ROL input [DPE COUT (1) H], which is the value of the C-bit prior to execution of the instruction. DPE SERIAL SHFT H equals this value of the C-bit and is loaded into BREG bit 00 via the SL input.

Rotate Right (ROR) – Rotates all bits right one place. Bit 15 loaded with C-bit.

The BREG is shifted right one place. ROT MUX 1 selects ROR input [DPE COUT (1) H], which is the value of the C-bit prior to execution of the the instruction. DPE SERIAL SHFT H equals this value of the C-bit and is loaded into bit 15 via the SR input. DPE RIGHT SHFT 07 H equals the bit 08 output of the BREG and is loaded into BREG bit 07 via the SR input to provide the connection from bit 08 to bit 07.

In each of these instructions, the C-bit is loaded with a new value from the BREG. This function is discussed in the description of the PSW logic.

8.3.7 Byte Instructions

For the correct execution of all instructions that operate on data, the least significant bit of both the source and destination must line up with bit 0 of the A-leg and B-leg, respectively. This same rule applies even if the instruction being executed is a byte operation. For even bytes this is no problem, since the data received from the Unibus has the least significant bit of the low order byte lined up properly. For odd bytes, it is necessary to shift the data word right eight bit positions to properly line up the data. Then if the destination is an odd byte, the data must be shifted eight bits left before it is restored to its proper memory location. This operation is illustrated in the example in Figure 8-10 with the associated processor flow.

8.3.8 Scratch Pad Memory

The scratch pad memory (SPM) is a 16-word by 16-bit random access read/write bipolar memory composed of four Type 7489 16-word by 4-Bit Memory Units. A block diagram of the SPM is shown in Figure 8-11. The SPM representation is contained on four logic prints as shown below.

SPM Designation	Print
E010	DPA
E012	DPB
E014	DPC
E016	DPD

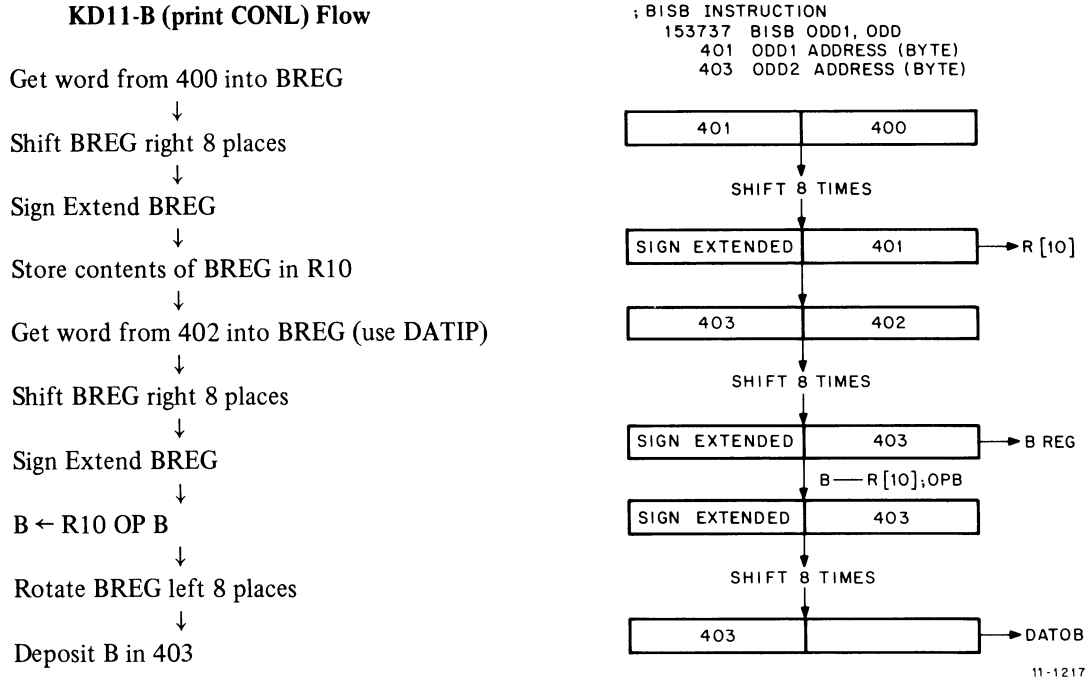

Figure 8-10 Byte Format for Shifting Instructions

The 16-word by 16-bit organization of the SPM provides 16 storage registers that are utilized as shown in Table 8-3.

Table 8-3
Register Utilization in SPM

Register Number	Designation
R0–R5	General Purpose
R6	Processor Stack Pointer
R7	Program Counter
R8 and R9	Unused
R10	Source Operand Storage
R11	Destination Operand Storage
R12	Interrupt Vector
R13–R16	Unused
R17	Load Address Storage

The SPM data inputs are the AMUX outputs: DPA AMUX 00 H-03 H, DPB AMUX 04 H-07 H, DPC AMUX 08 H-11 H, and DPD AMUX 12 H-15 H. The SPM outputs are the 16 ALEG bits (ALEG 00-15) which are sent to the A-word input of the ALU.

The SPM address line input signals are generated by the scratch pad address multiplexers (SPAM) as shown in Table 8-4.

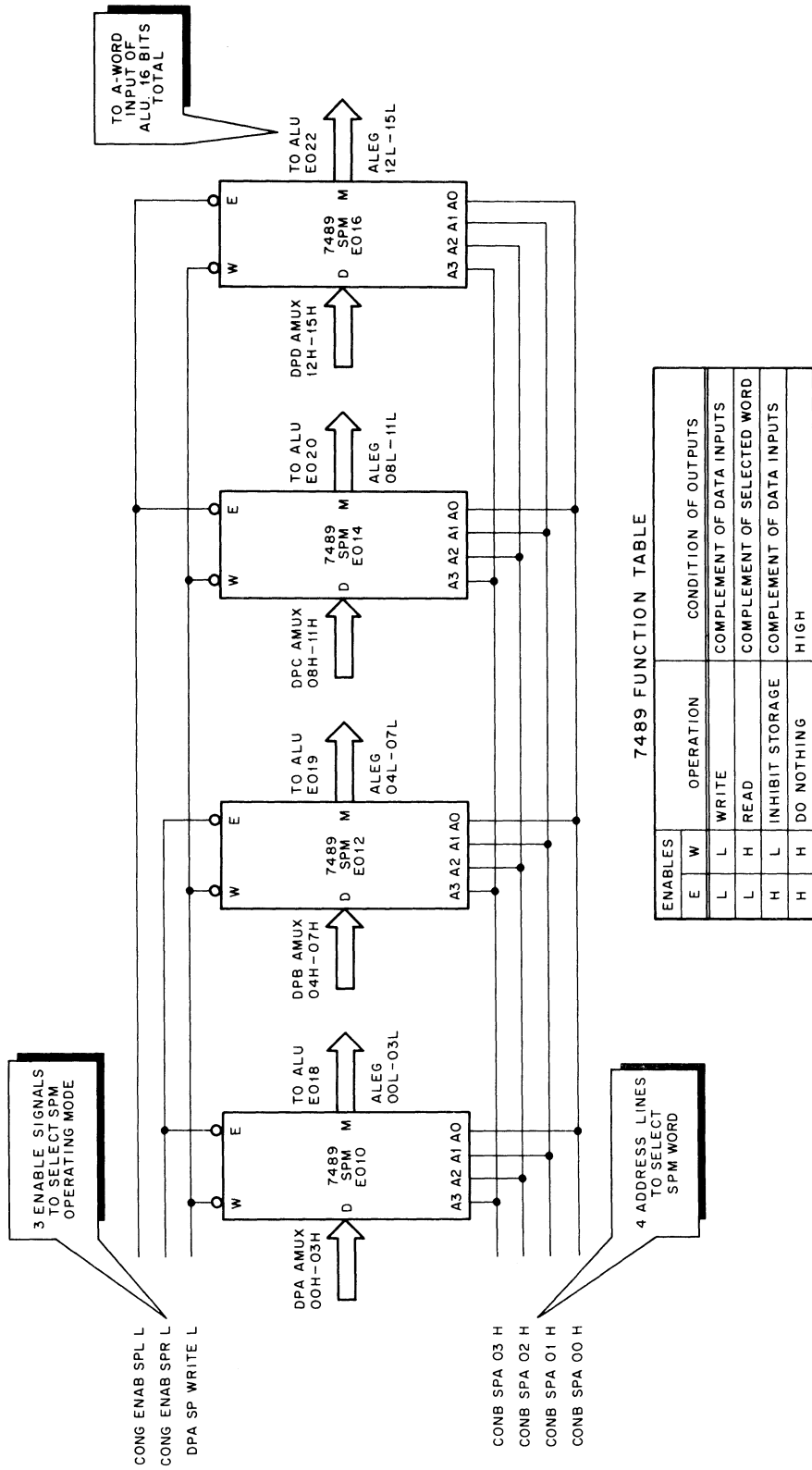

11-1565

Figure 8-11 Block Diagram and Function Table for Scratch Pad Memory

Table 8-4
SPM Address Line Signals

Signal	Source
CONB SPA 00 H	SPA MUX E056 (print CONB)
CONB SPA 01 H	SPA MUX E056 (print CONB)
CONB SPA 02 H	SPA MUX E057 (print CONB)
CONB SPA 03 H	SPA MUX E057 (print CONB)

Two enable inputs control the SPM mode of operation: input W (memory enable) and input E (write enable). The SPM function table is shown in Figure 8-11. Signal DPA SP WRITE L is the W-input. There are two E-input signals: CONG ENAB SPR L for the low byte (bits 00-07), and CONG ENAB SPL L for the high byte (bits 08-15). This allows word or byte operations to be performed on the SPM.

8.3.9 Scratch Pad Memory Address Multiplexer

The SPAM generates the four address signals that select the desired SPM word. The SPAM consists of two Type 74153 Dual 4-Line-to-1 Line Data Multiplexers. The SPAM is shown in print CONB (E056 and E057). Each of the four 4-line-to-1-line multiplexers (two per 74153 package) has a common strobe input signal (CONH RUN GND L) and common address input signals (CONG SPA MUX 00 H and CONG SPA MUX 01 H). Four data input sources are used and they are connected so that when the SPAM is addressed and strobed, it generates one 4-bit output, selected from one of the four sources. Table 8-5 lists the sources of the SPAM input data that are a function of the state of the processor.

Table 8-5
SPAM Input Data Sources

Function	SPAM Input	Source	Source Print
Source Operand Register Selection	B	Instruction Register Bits 06–08	DPF
Destination Operand Register Selection	C	Instruction Register Bits 00–02	DPF
General Purpose Register Selection From Console	A	Bus Address Register Bits 00–03	CONA
Register Selection By Microprogram	D	Control Store ROM Bits 12, 18, 21, 22	CONG

The SPAM address inputs are S1 (signal CONG SPA MUX 01 H) and S0 (signal CONG SPA MUX 00 H). They are generated by CS ROM 23-A13A2 (E106).

The data input selected is a function of the states of S1 and S0 as shown below.

Address Inputs		
S1	S0	Output
L	L	A
L	H	B
H	L	C
H	H	D

8.3.10 Processor Status Word Register

The processor status word register (PSW) contains information on the current priority of the processor, the result of the previous operation, and indicates a processor trap during debugging. The PSW bit assignments and use are shown in Table 8-6.

Table 8-6
Processor Status Word Bit Assignments

Bit	Name	Use
07-05	Priority	Set the processor priority.
04	Trace	When set, the processor traps the trace trap vector. Used for program debugging.
03	N	Set when the result of the last data manipulation is negative.
02	Z	Set when the result of the last data manipulation is zero.
01	V	Set when the result of the last data manipulation produces an overflow.
00	C	Set when the result of the last data manipulation produces a carry from the most significant bit.

The PSW is loaded as a result of instruction execution, program traps, I/O interrupts, and returns to main-line code. In the case of a program trap, interrupt, or return, the PSW is loaded with the second word of the vector from the Unibus data lines via the AMUX. Otherwise, the PSW is loaded through a network of multiplexers and combinational logic that is controlled by the particular instruction being executed.

The PSW is an 8-bit flip-flop register (print DPE). The condition code bits (N, Z, V, and C) are stored in 7474 D-type flip-flops (E050 and E051). The priority bits and T-bit are stored in a 74175 quad D-type flip-flop called PSW 7:4 (E042). The output of the T-bit flip-flop is sent to another flip-flop (T DEL) which is used as the trap flag.

The input source for the condition code bits is the output of the condition code multiplexer (CC MUX). The CC MUX (E052 print DPE) is a Type 74157 Quad 2-Line-to-1-Line Multiplexer. One of the two 4-bit inputs is selected by the states of the strobe (E) and select (S) inputs. When E is low and S is high, the B-input is selected to the D-inputs of the condition code flip-flops (NEG, ZERO, VBIT, and COUT). The B-input consists of AMUX outputs

DPA AMUX 00 H-03 H. When E and S are both low, the A-input is selected. The A-input consists of signals from the ROT CC MUX (E056 print DPE) and the C and V BIT ROM (E082 print DPF). These devices are part of the logic used in setting the condition codes as a function of instruction execution and are described in detail in subsequent paragraphs.

The input source for the priority bits (PSW 05-07) consists of AMUX outputs DPB AMUX 05 H-07 H which are sent to D-inputs D1, D2, and D3 of E042. Signal DPB AMUX 04 H is sent to D-input D0 of E042 as the source of the T-bit.

The PSW is loaded when the flip-flops are clocked. Each bit is clocked by the processor clock signal CONJ PROC CLOCK H which is free running as long as the clock is not inhibited. Clock control is provided by gating other signals with CONJ PROC CLOCK H. These signals and the PSW bits that they control are shown below.

Control Signal	PSW Bit
CONG LOAD PSW L	N, Z, V, C, T and Priority
DPF AUX DEL (1) L	N, Z, and V
DPF C CLK DEL (1) L	C

The logic that determines the condition code bits (C, V, N, and Z) and loads them in the PSW register is shown in prints DPE and DPF.

This discussion covers the determination and loading of the condition code bits as a result of instruction execution. Two categories of instructions are discussed: normal arithmetic instructions, and rotate and shift instructions.

Before discussing specific examples in these categories, the functional units of the logic are described briefly.

CC MUX

As mentioned previously, the condition code bits are loaded from the outputs of the CC MUX (E052, print DPE). The CC MUX is a Type 74157 Quad 2-Line-to-1-Line Multiplexer. Only the 4-bit A-input is used during instruction execution. The A-input is selected when the E-input and the S-input are both low. The E-input is the strobe and must be low to enable the multiplexer. It is connected to CONH PROC INIT H from the power fail circuit which is low when power is up. The S-input selects the input (A or B) and is connected to DPF AUX DEL (1) L which is control store bit CONF AUX CONTROL L that has been stored in flip-flop E054 (print DPF). Signal CONF AUX CONTROL L is the AUX field (bit 24) of the control store word. It is generated by CS ROM E094 (print CONF) and enables the auxiliary ALU control when it is low. This is the desired condition to select input A of the CC MUX.

C and V BIT ROM

The C and V BIT ROM (E082, print DPF) calculates the values of the C-bit and V-bit for normal arithmetic instructions. The DPF SET COUT H output is modified by 3-input NAND gate E067 only during the execution of a subtract instruction. For shift and rotate instructions, the C-bit is determined by the two NAND gates wire-ORed to the DPF SET COUT L output of the C and V BIT ROM. For these instructions, the V-bit is determined by the exclusive-OR gate and NAND gate connected to the DPF SET V L output of the C and V BIT ROM. The five inputs to the C and V BIT ROM are delayed the equivalent of one clock pulse by being sent to hex flip-flops E054 and E093 before being sent to the ROM. The delay is required to allow time for the C and V BIT ROM to settle. These input signals come from three sources: the B-leg, ROT CC MUX (E068), and SOP AUX CTL ROM (E068).

ROT CC MUX

The ROT CC MUX (E056, print DPE) determines the value of the N-bit and Z-bit. It is a Type 74153 Dual 4-Line-to-1-Line Multiplexer. The outputs are DPE NEG H (for the N-bit) and DPE SET Z H (for the Z-bit). These outputs are delayed by flip-flop E054 before being applied to the CC MUX whose outputs condition the D-inputs of NEG flip-flop E052 and ZERO flip-flop E050. The inputs of both sections of the ROT CC MUX are a function of the category of instruction being executed.

Instruction Category	Input Designation
Rotate Byte	\overline{BR}
Byte (not Rotate)	\overline{BR}
Rotate (not Byte)	\overline{BR}
Not Byte or Rotate	\overline{BR}

The enabling or strobe (STB1 and STB2) inputs for the ROT CC MUX are both connected to ground which enables the multiplexer. Inputs S1 and S2 are the address inputs and are common to both sections. The data inputs are selected by the states of S1 and S2 according to the following truth table.

Address Inputs

S1	S0	Selected Input
L	L	\overline{BR}
L	H	\overline{BR}
H	L	\overline{BR}
H	H	BR

Input S1 is connected to DPG BYTE H, which is an inverted output of IR decoding ROM E069. Input S0 is connected to DPF ROTATE H, which is an inverted output of SOP AUX CTL ROM E068. This signal is a function of the instruction register output.

The data signal inputs to the ROT CC MUX are shown below.

ROT CC MUX Input Signals For DPE NEG H Output Section			ROT CC MUX Input Signals For DPE SET Z H Output Section		
Pin	Desig	Signal	Pin	Desig	Signal
13	\overline{BR}	} DPE ROT NEG H	04	\overline{BR}	DPA 0-7 = 0H
11	\overline{BR}		06	\overline{BR}	DPE 0-15 = 0H
12	\overline{BR}	DPB AMUX 07H	03	BR	Output of gate E055 pin 10 (zero detector for BLEG bits 01-06)
10	\overline{BR}	DPD AMUX 15H			
			05	\overline{BR}	Output of gate E055 pin 13 (zero detector for BLEG bits 01-14)

ROT MUX 2

The ROT MUX 2 (E049, print DPE) generates outputs which are used in computing the C-bit and N-bit for arithmetic shift instructions ASL and ASR, and rotate instructions ROL and ROR. It is a Type 74153 Dual 4-Line-to-1-Line Multiplexer. Output DPE ROT COUT H is sent to flip-flop E093 and then to the C-bit logic (print DPF). Output DPE ROT NEG H is sent to input \overline{BR} (pin 11) and input BR (pin 13) of the ROT CC MUX. The inputs of both sections of the ROT MUX 2 are a function of the specific type of instruction being executed. The instructions are listed below.

Instruction	Input
Arithmetic Shift Left	ASL
Arithmetic Shift Right	ASR
Rotate Left	ROL
Rotate Right	ROR

The enabling inputs (STB1 and STB0) are both connected to ground which enables the multiplexer. The data inputs are selected by the states of address inputs S1 and S0 according to the following truth table.

Address Inputs		Selected Inputs
S1	S0	
L	L	ROR
L	H	ASR
H	L	ROL
H	H	ASL

The address inputs are connected to DPA ALU S1 H (input S1) and DPA ALU S0 H (input S0) which are inverted and buffered control store bits 28 and 29 from CS ROM E104 (print CONF). The actual signals are CONF ALU S1 L and CONF ALU S0 L which are part of the ALU field that picks the function to be performed by the ALU. These signals can be used by ROT MUX 1 and ROT MUX 2 because the ALU and these multiplexers are never used simultaneously. The data signal inputs to the ROT MUX 2 are shown below.

ROT MUX 2 Input Signals For DPE ROT COUT H Output Section			ROT MUX 2 Input Signals For DPE ROT NEG H Output Section		
Pin	Desig	Signal	Pin	Desig	Signal
13	ASL	} DPD BREG 15 (1) H	03	ASL	} DPE L SHIFT SIGN H
12	ROL		04	ROL	
11	ASR	} DPA BREG 00 (1) H	05	ASR	DPD BREG 15 (1) H
10	ROR		06	ROR	DPE COUT (1) H

ROT MUX 1

The ROT MUX 1 (E048, print DPE) generates the enabling signal for the rotate and shift zero-detection logic and generates a serial input signal for the BREG. It is a Type 74153 Dual 4-Line-to-1-Line Multiplexer. Output F₀ (pin 07) is the enabling signal for the BLEG zero-detection gates E029 and E031. Output DPE SERIAL SHIFT H is a serial input signal for the BREG. It is also sent to the input of the BYTE MUX (E047, print DPE). The inputs to the ROT MUX 1 are a function of ASL, ASR, ROL, and ROR instruction execution. This multiplexer uses the same enabling signals and truth table as the ROT MUX 2. The data signal inputs to the ROT MUX 1 are shown below.

ROT MUX 1 Input Signals For DPE SERIAL SHFT H Output Section			ROT MUX 1 Input Signals For Output Section That Enables Gate E029		
Pin	Desig	Signal	Pin	Desig	Signal
13	ASL	DPA RUN GND L	03	ASL	DPA BLEG 00 L
12	ROL	} DPE COUT (1) H	04	ROL	Output of gate E055 pin 04 ($\overline{BR00} \cdot \overline{COUT}$)
10	ROR		05	ASR	DPD BLEG 15 L
11	ASR	DPD BREG 15 (1) H	06	ROR	Output of gate E055 pin 01 ($\overline{BR15} \cdot \overline{COUT}$)

The following example covers the determination of the condition code bits for the negate (NEG) instruction. When the NEG instruction is executed, the disposition of the condition code bits is as follows:

- C – cleared if the result is 0; set otherwise
- V – set if the result is 100000; cleared otherwise
- Z – set if the result is 0; cleared otherwise
- N – set if the result is less than 0; cleared otherwise

The condition code bits depend on the result produced by the instruction. For this example, assume that the result is 001000₈.

The C-bit should be set because the result is not zero, and the V-bit should be cleared because the result is not 100000₈. The C and V BIT ROM calculates the C and V bits: DPF SET COUT H is high and DPF SET V H is low. Verification of these signals is accomplished by checking the outputs of the C and V BIT ROM back to their sources, which are the associated ROM maps.

The N-bit should be cleared because the result is greater than zero. The NEG instruction is not a byte and not a rotate instruction: therefore, the BR input of the ROT CC MUX is selected, which is DPD AMUX 15 H for the top section of this dual multiplexer. This signal is low so ROT CC MUX output DPE NEG H is low. This signal is delayed by flip-flop E054 and its output is sent to the CC MUX to load a 0 into the NEG flip-flop E051 (N-bit is cleared).

The Z-bit should be cleared because the result is not zero.

The BR input of the ROT CC MUX is selected: DPE 0-15 = 0 H for the bottom section of the multiplexer. This signal is low because all bits of the result are not zero; therefore, output DPE SET Z H is low. This output is delayed by flip-flop E054 and its output is sent to the CC MUX to load a 0 into the ZERO flip-flop E051 (Z-bit cleared).

The following example covers the determination of the condition bits for the arithmetic shift-right (ASR) instruction. This instruction requires the use of some additional PSW logic.

When the ASR instruction is executed, the disposition of the condition code bits is as follows.

C – loaded from the low order bit (00)

V – loaded with the exclusive-OR of the N-bit and the C-bit at completion of the shift operation.

Z – set if the result is 0; cleared otherwise.

N – set if the result is less than 0; cleared otherwise.

The condition code bits depend on the result produced by the instruction. For this example, assume that the result is 000002₈.

For this instruction, input ASR is selected for both sections of ROT MUX 1 and ROT MUX 2. Input BR is selected for ROT CC MUX because the ASR instruction is not a byte but it is considered to be a rotate instruction.

First, consider the C-bit, which is loaded from the low order bit. The output of the top section of ROT MUX 2 is DPE ROT COUT H. In this example, the selected input is DPD BREG 00 (1) H, which is low because bit 00 of the result is low: this makes output DPE ROT COUT H low. It is sent to flip-flop E093 and then on to the C-bit logic (print DPF) as DPF ROT C DEL (1) H. For the ASR instruction, C and V BIT TOM E082 is disabled by holding its enabling signal high.

Determination of the C-bit is handled by NAND gates E092 (2), E067 and exclusive-OR gate E08 (Figure 8-12). The two E092 gates are wire-ORed with the DPF SET COUT L output of the C and V BIT ROM. For the ASR instruction, DPF SET C DEL (1) H is low and is sent to both inputs of one of the E092 gates. This produces a high at E092 pin 08 which is one gate of the wired-OR connection. Signal DPF ROT DEL (1) H is sent to one input (pin 12) of the other E092 gate. It is high, which means that the output of this gate (pin 11) is controlled by signal DPF ROT C DEL (1) H to input pin 13. This signal is low so the wired-OR connection (DPF SET COUT L) is high. Signal DPF SET COUT L is sent to pin 10 of exclusive-OR gate E081. The other input (pin 09) of this gate is high because a subtract instruction is not being executed. The exclusive-OR output is low. This is signal DPF SET COUT H and it is sent to the CC MUX to reset COUT flip-flop E051. Thus, the C-bit is loaded with a 0 from the low order bit (00).

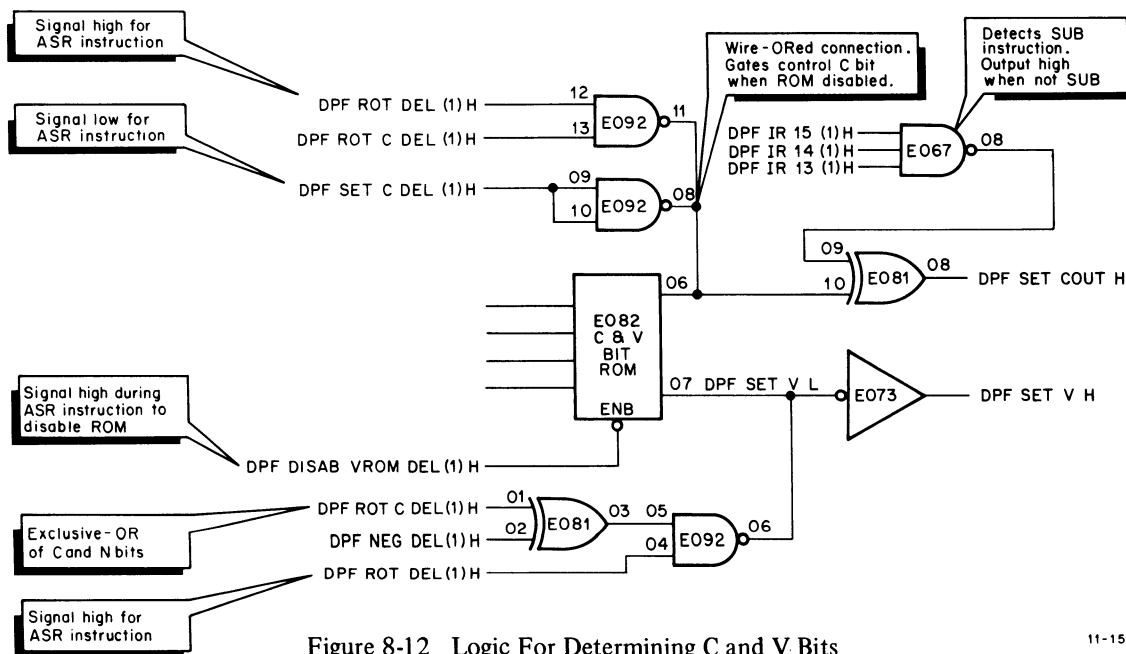

Figure 8-12 Logic For Determining C and V Bits
(Example Shown for ASR Instruction)

11-1565

Next, consider the N-bit, which is cleared because the result is greater than 0 (bit 15 is a 0). Output f_1 of ROT CC MUX is DPE NEG H. In this example, the selected input (BR) is DPE ROT NEG H. This is output f_0 of ROT MUX 2, and in this case, the selected input (ASR) is DPD BREG 15 (1) H which is low because bit 15 of the result is low. Output f_0 , which is DPE ROT NEG H, is low and as a result, DPE NEG H from the ROT CC MUX is low. This signal is delayed by flip-flop E054 and its output [DPF NEG DEL (1) H] is sent to the CC MUX to reset NEG flip-flop E051 (N-bit cleared). Signal DPF NEG DEL (1) H is also sent to the logic that determines the V-bit.

Next, consider the V-bit, which is the exclusive-OR of the N-bit and the C-bit. As mentioned, the C and V BIT ROM is disabled during the execution of the ASR instruction. Determination of the V-bit is handled by exclusive-OR gate E081, NAND gate E092 and inverter E073. The exclusive-OR gate performs the exclusive-OR function of the N and C bits and its output is connected to the DPF SET V L output of the C and V BIT ROM. This output is inverted by E073 to produce DPF SET V H. The inputs to exclusive-OR gate E081 are DPF ROT C DEL (1) H and DPF NEG DEL (1) H which are both low (refer to previous discussions of C-bit and N-bit). The output (pin 03) of the exclusive-OR gate is low and is sent to pin 05 of NAND gate E092. The other input of this gate is DPF ROT DEL (1) H and it is high during execution of the ASR instruction. The output of this gate is high and it is inverted by E073 to produce DPF SET V H which is low. This signal is sent to the CC MUX to reset V BIT flip-flop E051. Thus, the V-bit is loaded with the exclusive-OR of the C and N bits, which is zero.

Finally, consider the Z-bit, which is cleared because the result is not zero. Output f_0 of ROT CC MUX is DPE SET Z H. In this example, the selected input (BR) comes from gate E055 pin 13, which is an output of the rotate and shift zero-detection logic. Gate E055 produces a low because the enabling signal for this logic is not asserted. The enabling signal comes from output f_0 of ROT MUX 1 that selects DPD BLEG 15 L for an ASR instruction. In this case, bit 15 is low; therefore, DPE SET Z H is low. This signal is delayed by flip-flop E054 and its output is sent to the CC MUX to reset ZERO flip-flop E051. Thus the Z-bit is cleared.

8.3.11 Constants Generator

The constants generator consists of a single 32-word by 8-bit ROM attached to the A-leg of the ALU. It is identified as E025 CONSTANTS (part number 23-A01A1) and is shown on print DPB. The outputs of the constants generator are addresses of trap vectors and the complement of the address of the console switch register. Each output is an 8-bit word that is sent to the low order byte of the ALU A-leg. The eight bits are identified as DPB ALEG 00 L-07 L.

Four of the five inputs to the constants generator are CONB SPA 00 H-03 H which are generated by the SPAM (E056 and E057, print CONB). It is possible for both the constants generator and the SPM to use these signals because they are never used simultaneously. The fifth input is CONG SP WRITE H, which is also used by the SPM. It is an inverted output of control store ROM E095 (part number 23-A07A2) in print CONG.

The enabling input for the constants generator is CONE ALLOW CONSTANTS L which is an output of the BUT DECODE multiplexer E078 (print CONE). This multiplexer is driven by control store ROM E105 (part number 23-A12A2) in print CONG.

The contents of the constants generator are shown in ROM listing K-RL-M7260-0-8, sheet 2.

8.3.12 Console Switch Register

The settings of the 16 switches in the console Switch Register are transmitted in parallel via a cable to the Berg connector on the M7260 Data Paths Module. On the console (print 5409766-0-1, sheet 3), these signals are identified as SW 00 (1) H-SW15 (1) H. On the M7260 module, these signals are identified as EXTRA SWITCH REG 00 H-15 H.

These signals enter the data path via four Type 74H01 Quad 2-Input NAND Gates as shown below.

Bits	Gate	Print
00-03	E028	DPA
04-07	E024	DPB
08-11	E021	DPC
12-15	E023	DPD

The gates are enabled by DPA ENAB SWITCH REG H, which is the output of 7437 NAND buffer gate E083 (print DPA). The input to this gate is CONA ENAB SWITCH REG L, which is an output of DATI ADDRS DECODE ROM E069 (part number 23-A09A1) in print CONA.

8.3.13 Console Multiplexer

The console multiplexer scans the 16 bits in the BLEG, serializes the information, and transmits it via a cable to the console Buffer Register. It is a 74150 data/selecter multiplexer and is identified as E30 CONSOLE MUX (print DPE). Figure 8-13 is a block diagram of the console multiplexer and its input source.

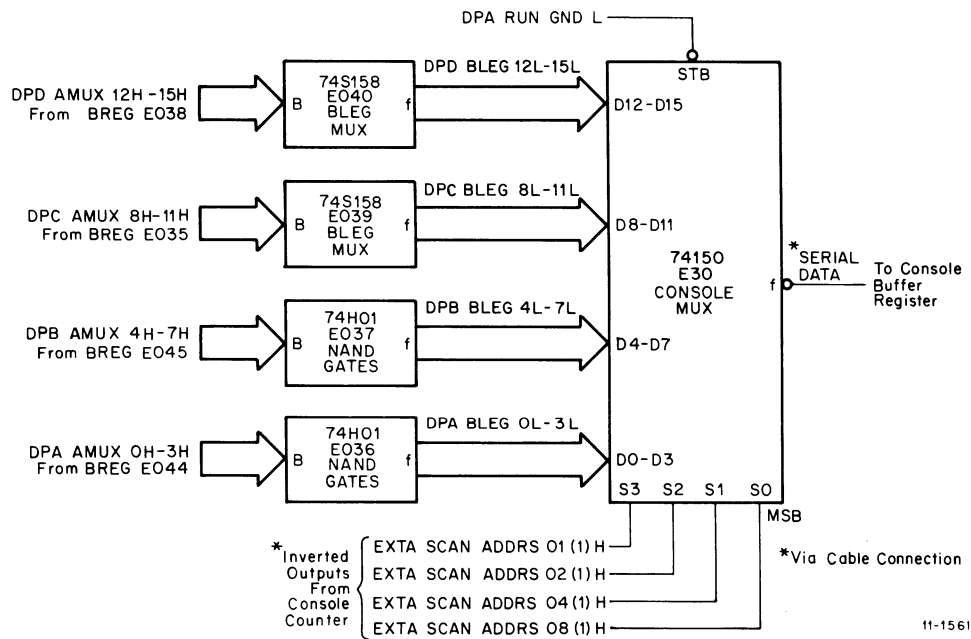

Figure 8-13 Console Multiplexer Block Diagram

The CONSOLE MUX (E30 print DPE) selects one of sixteen inputs in accordance with the states of the four data select lines (S0-S3). A low strobe signal enables the selected input to the output in the inverter state.

The high byte input (D8-D15) of the CONSOLE MUX comes from the output of the BLEG multiplexer. These signals are DPC BLEG 8-11 and DPD BLEG 12-15 L. The low byte input (D0-D7) comes from the open-collector NAND gates (E036 and E037, prints DPA and DPB) that are driven by the B register. The four data select inputs (S0-S3) are the inverted outputs of the console counter (E6 print 5409766-0-1, sheet 3). These signals are EXTA SCAN ADDRS 01 (1) H, -02 (1) H, -04 (1) H, and -08 (1) H. They are decoded as a BCD number with 08 (1) H

being the most significant digit. These lines select the input lines on an equivalent basis; for example, a decoded decimal 6 selects input D6. The strobe signal DPA RUN GND L is held low to enable the selected input to the output.

8.4 INSTRUCTION DECODING

8.4.1 Introduction

Two methods are used to control instruction decoding. One uses microroutine selection and the other uses auxiliary ALU control. Dual control is required because of the large number of instructions that require source/destination calculations. Auxiliary ALU control is evoked whenever the microcode executes the action $B \leftarrow R10 \text{ OP } B$ as a result of a specific instruction.

There are two prerequisites to a thorough understanding of the instruction decoding procedure. One is a knowledge of the microbranching process (Chapter 9) and the other is a knowledge of the PDP-11 instruction format (Chapter 6).

Certain facts concerning the PDP-11 instruction set are listed below.

- a. In general, the PDP-11 operation code is variable from 4 to 16 bits.
- b. Instructions are decoded from the most significant part of the word towards the least significant part of the word beginning with the most significant four bits.
- c. There are a number of instructions that require two address calculations and a larger number that require only one address calculation. There are also a number of instructions that require address calculations, but do not operate on data.
- d. All OP codes that are not implemented in the KD11-B processor must be trapped.
- e. There are illegal combinations of instructions and address modes that must be trapped.
- f. There exists a list of exceptions in the execution of instructions having to do with both the treatment of data and the setting of condition codes in the program status word.

8.4.2 Double Operand Instructions

Double operand instructions are decoded by ROM E066 (print DPG). Four inputs to E066 are DPF IR 12 (1) H - DPF IR 15 (1) H; these are outputs of the Instruction Register (E058, print DPF) which represent the OP code of a double operand instruction. The fifth input is CONE BUT DESTINATION L which is an output of the E078 BUT DECODE demultiplexer. The inputs to E078 are CONG BUT 00 L - CONG BUT 03 L which are the four bits of the BUT field of the control store word. When a double operand instruction is decoded, E066 output signal DPG CAL SOURCE L is asserted. This signal is ANDed with CONE BUT IR DECODE L at gate E079 to produce signal CONF MPC 07 L at pin 11 of quad NAND gate E072. The output of gate E079 is ANDed with DPF IR 09 (1) H, DPF IR 10 (1) H, and DPF IR 11 (1) H to produce CONF MPC 01 L, CONF MPC 02 L, and CONF MPC 03 L at the three remaining sections of quad NAND gate E072 (lower center section of print DPG). These four signals represent four bits of the 8-bit NXT field of the control store word and cause a microcode branch.

ROM E066 also generates DPG CMP + BIT L which indicates that the instruction does not modify the destination operand. Output signals DPG MOVE L and DPG BYTE L are used in the microbranch logic (print CONE). Table 8-7 explains the use of these signals.

Table 8-7
Effect of E066 Outputs DPG CMP+BIT L,
DPG MOVE L, and DPG BYTE L

Instruction	E066 Output Signal	Effect	Remarks
CMP	DPG CMP+BIT L	Set condition codes	Destination is not modified; therefore, DATIP is not required.
BIT	DPG CMP+BIT L	Set condition codes	Destination is not modified; therefore, DATIP is not required.
MOVB	DPG MOV L DPG BYTE L		If the destination is a register, (i.e., destination mode 0) the result is sign extended; i.e., the sign of the low order byte is extended through the upper byte.
(ANY) BYTE	DPG BYTE L		Bit 0 of the address word must be used in determining which microroutine to use position source and destination data. See Chapter 9, for details.

For a binary operand instruction, the source operand is stored in R10 and the destination operand is temporarily stored in the B register. Then the control step $B \leftarrow R10 \text{ OP } B$ is performed. The ALU can perform the operation A-leg minus B-leg, but not the converse. The CMP instruction requires the operation source minus destination, which is equivalent to A-leg minus B-leg; however, the SUB instruction requires the operation destination minus source. This is accomplished by storing the complement of the source in R10 for the SUB instruction only. The signal CONE BUT DESTINATION L is an input to E066. The microprogram issues CONE BUT DESTINATION L, whenever the SOURCE operand is stored in R10. If the current instruction is a SUB, E066 issues the signals DPG DIS ALU S BITS H, CONF ALU SO L, and CONF ALU S2 L. This causes the complement of the BREG to be sorted in R10. When control step $B \leftarrow R10 \text{ OP } B$ is performed for the subtract instruction, the ALU operation is A-leg plus B-leg plus 1, which is equivalent to destination minus source.

When the microprogram has completed the source calculation and retrieved the source operand for a binary operand instruction, it generates the signal CONE BUT DESTINATION L. This signal is ORed and inverted to produce CONE BUT DESTINATION H. The MOV, MOVB, CMP and BIT instructions are detected at the control steps listed below:

Bit Patterns	Instruction Class	Asserted Signals
(11) = (9) = (8) = 1 + (10) = 0	Unary Potential TST	DPG CAL DEST L + DPG 54 L
(10:08) = 0 + (11) = 0	Branch	DPG CAL BRANCH L
(15:08) = 0	Other	DPG ODD BYTE = 0L

Two instructions in the other class require destination calculations: JMP and SWAB. These instructions are detected by ROM E074 shown in the lower left-hand corner of DPG. Standard unary instructions that affect or test the destination (with the exception of SWAB) are treated as binary instructions; i.e., the instruction is fetched, the operand is fetched, the operation is performed, and the operand is returned. The logic that decodes the operation for $B \leftarrow R10 \text{ OP } B$ is shown on print DPF. For unary operand instructions, the destination operand is copied into both R10 and B.

8.4.3 Branch On Unary

There are three formats of instructions that require destination address calculations. The majority of the microcode destination routines are shared by all of the instructions that have destination fields. ROM E071, shown in upper right-hand corner of print DPG, is used to differentiate between the various instructions that use the microcode destination routines.

E071 is also used to detect illegal instruction combinations, which are defined as JMP or JSR and used with destination mode 0. The microcode flow chart shows that in microstep D0-2 a test is made for unary and illegal instructions by asserting the signal CONE BUT UNARY L. CONE BUT UNARY L produces the signal CONE ENAB UNARY L, which enables E071 (print DPG) to cause a microprogram branch. At other points in the microprogram such as D2-3, a test is made for a legal JSR or JMP instruction by the assertion of the signal CONE JMP + JSR L. The asserted signal CONE JMP + JSR L alters the input to E071 such that microroutines for legal JSR and JMP instructions are used. Signal CONE JMP + JSR L also causes the generation of the signal CONE ENAB UNARY L, which enables E071.

The effect of ROM E071 (part number 23-A10A1) is determined by observing its data pattern shown in drawing K-RL-M7260-0-8, sheet 9.

8.4.4 PDP-11 Branch Instruction

PDP-11 conditioned branch instructions are completely decoded by E059, shown on print DPG. E059 is enabled by the signal DPG CAL BRANCH L, which is asserted by E069 according to a previously discussed algorithm. IR (15) and IR (10:08) along with the condition codes N, Z, V, and C completely determine the branch instruction disposition. The offset of a branch instruction is sign-extended in microstep F-5 and shifted left one place in microstep B-1. All successful branch instructions are interpreted by the microroutine that begins in B-1, while all unsuccessful branch instructions are interpreted by the microroutine that begins in B2-1.

8.4.5 Operate Instructions

Operate instructions and instructions that set and clear condition codes are decoded by E074 and E064. NOPS, set condition code instructions, and clear condition code instructions all proceed from step F-5 to step CCM-1 in the microprogram. At step CCM-2, the microprogram performs a BUT DESTINATION to examine IR (4). Set condition code instructions and the NOP-260 proceed with step SC-1 while clear condition code instructions and the NOP-240 proceed with step CC-1. Also in step CCM-1, the B register is loaded with the contents of the instruction ANDed with 17_8 . This procedure zeroes all but the least significant four bits of the instruction copy contained in the B register. Remember that the instruction is loaded into both the IR and B register in step F-4. If the instruction is a SET COND CODE type, the operation is $PSW \leftarrow B$ or PSW in step SC-1. Similarly, for clear condition code instructions, $PSW \leftarrow B$ and not PSW is performed in step CC-1. Even though the entire PSW is reloaded, only the least significant four bits are effected by the sequence just described.

Other operate instructions such as WAIT, RTI, and HALT are decoded completely when BUT IR DECODE is issued during microstep F-5.

8.4.6 Auxiliary ALU Control

The auxiliary ALU control consists of the ROMs E053, E061, and E068 shown on print DPF. These ROMs determine the operation to be performed whenever the microcode executes the action $B \leftarrow R10 \text{ OP } B$. E053 decodes binary operand instructions while the other two ROMs decode unary operand instructions. Table 8-8 shows the auxiliary control outputs for binary and unary instructions.

Table 8-8
Auxiliary Control for Binary and Unary Instructions

Inst.	Condition Codes			ALU Function	CIN	B
	N and Z	V	C			
MOV (B)	Load	Cleared	Not Effected	A Logical	0	Load
CMP (B)	Load	Load like SUBTRACT	Load like SUBTRACT	A - B - 1	+1	Load
BIT (B)	Load	Cleared	Not Effected	A + B	0	Load
BIC (B)	Load	Cleared	Not Effected	$\sim A + B$	0	Load
BIS (B)	Load	Cleared	Not Effected	AB	0	Load
ADD	Load	Set if OP's same sign and result different.	Set if carry out	A plus B	0	Load
SUB	Load	$\left. \begin{array}{l} + - (-) = - \\ - (-) (+) = + \end{array} \right\} \text{Set}$	Set if Carry	A plus B	+1	Load
CLR (B)	Load	Cleared (like ADD)	Clear	0	0	Load
COM (B)	Load	Cleared	Set	$\sim B$ Logical	0	Load
INC (B)	Load	Set if dst held 100000 before OP	Not Effected	$A \dot{A}$	+1	Load
NEG (B)	Load	Set if result is 100000	Cleared if result is 0; set otherwise	A - B - 1	+1	Load
ADC (B)	Load	Set if dst was 077777 and C = 1.	Set if dst was 177777 and C = 1.	A Arithmetic	+C	Load
SBC (B)	Load	Set if dst was 100000.	Cleared if dst was 0 and C = 1; set otherwise.	A - B	$\sim C$	
TST (B)	Load	Cleared	Cleared	A Logical	0	Load
ROR (B)	Z \leftarrow (C:01) N \leftarrow C	N \oplus C	(0)			Shift Right
ROL (B)	Z (14:C) N \leftarrow (14)	N \oplus C	(15) B (7)			Shift Left
ASR (B)	Z \leftarrow (15:01) N \leftarrow N	N \oplus C	C \leftarrow (15)			Shift Right
ASL (B)	Z \leftarrow (14:01) N \leftarrow (14)		C \leftarrow (15)			Shift Left

8.5 PROCESSOR CLOCK

The KD11-B processor clock is shown in print CONJ. A single astable oscillator is used to generate a pulse train to which the entire processor is synchronized. Since it is a fully clocked processor, events that result in the alteration of storage registers occur only on a defined edge of the processor clock pulse.

The logic diagram for the processor clock is shown in print CONJ. A timing diagram is shown in Figure 8-14. NAND Schmitt trigger E019 is connected as an astable multivibrator (oscillator). It does not require a trigger and is free running as soon as +5V is applied to its input via resistor R1. The period of the oscillator pulse output should be set for 150 ns. Adjustable resistor R10 is used to set the period. The oscillator can be disabled by a low signal from NAND gate E13 pin 13. This low signal is asserted during the time that a Unibus transaction is in process. The processor clock is disabled during this time. The oscillator output is sent to one input of 2-input NAND gate E027. The other input (pin 13) is held high by +5V via resistor R3. The oscillator pulses are inverted by E027 and are sent to the triggering input of one-shot E009. During maintenance with the KM11 Maintenance Module installed, gate E027 allows the processor clock to be single stepped. The oscillator input is connected to +5V via R1 and to pin FV1 on the M7261 module. This input is grounded by the maintenance module to disable the oscillator. Input pin 13 on gate E027 is connected to +5V via R3 and to pin FU2 on the M7261. A switch on the maintenance module grounds this line (CONJ S CLK ON L) to provide a positive transition at the output of E027 to trigger the one-shot. This action provides a single processor clock pulse.

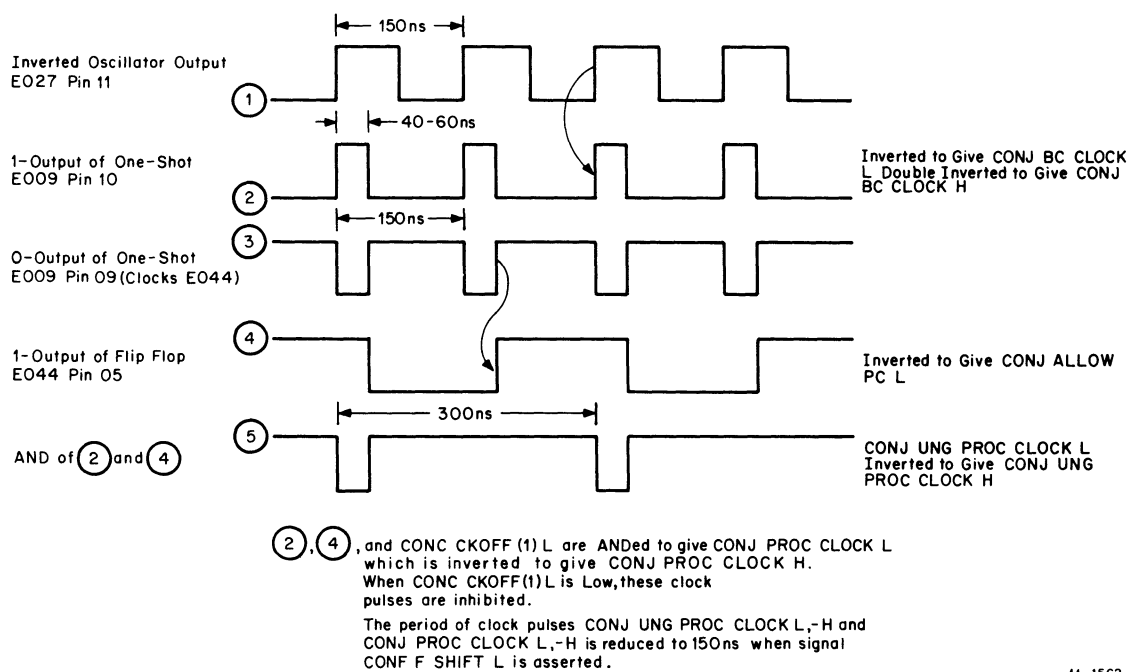

Figure 8-14 Processor Clock Timing Diagram

During normal operation, the oscillator output is fed to pin 12 of one-shot E009. The other input (pin 11) is held high by CONI R5 H. This line is connected to +5V via resistor R5 (print CONI). With pin 11 high, a positive transition at pin 12 triggers one-shot E009. A positive pulse is generated at output pin 10 and a negative pulse is generated at output pin 9. These pulses are 40-60 ns wide. A pulse is initiated on every positive transition of the inverted oscillator output (E027 pin 11). The positive pulse from the one-shot is sent to high speed NAND buffer E054. The inverted pulse from the output (pin 08) of E054 is called CONJ BC CLOCK L. This signal is inverted and buffered by another E054 high speed NAND buffer whose output (pin 06) is called CONJ BC CLOCK H. These two clock signals have 150-ns periods and are buffered to provide increased fanout capability.

The negative pulse from the one-shot is sent to the clock (C) input of flip-flop E044. The 1-input of the flip-flop is fed back to its D-input via 2-input NAND gate E045. Normally, the other input of this gate (CONF F SHFT L) is high so the 1-output is inverted before being fed back to D-input. The clear input (pin 01) and the preset input (pin 04) of the flip-flop are kept disabled by CONJ R24 H, which is connected to +5V via resistor R24. This is a toggle

configuration and the flip-flop changes state on every positive transition of the clock pulse. The 1-output of the flip-flop represents a division by 2 of the oscillator output; i.e., a bipolar pulse train with a period of 300 ns. This signal is sent to NAND gate E064 where it is inverted to generate CON J ALLOW PC L. The 1-output of the flip-flop is also sent to NAND gate E045 and high speed NAND buffer E055. At gate E045, the flip-flop 1-output is ANDed with the positive output of the one-shot to generate a 40-60 ns negative pulse every 300 ns that is called CONJ UNG PROC CLOCK L. This signal is inverted by open-collector inverter E061 to produce CONJ UNG PROC CLOCK H. At gate E055, the flip-flop 1-output, the positive output of the one-shot, and signal CON CKOFF (1) L are ANDed to generate another 40-60 ns negative pulse every 300 ns. This signal is called CONJ PROC CLOCK L and is buffered to provide increased fanout capability. Signal CONJ PROC CLOCK L is inverted by high speed NAND buffer E055 to produce CONJ PROC CLOCK H. These clock signals are inhibited when CON CKOFF (1) L is low. This occurs when the processor is awaiting the completion of a Unibus interrupt or a RESET instruction. Signal CONC CKOFF (1) L is an output of CKOFF flip-flop E080 (print CONC) and is low when the flip-flop is set. This redefined flip-flop is set when its D-input (CONG CKOFF L) is low. This signal is the CK0 field of the control store word and is generated by CS ROM E107 (print CONG).

As previously mentioned, the 1-output of flip-flop E044 is sent to 1-input of NAND gate E045. The other input is CONF FSHFT L, which was previously identified as CONF SPARE L. It is generated by CS ROM E094 and is a field of the control store word. Normally, this signal is high and flip-flop E044 performs its divide-by-2 function to provide a 300-ns period for clock signals CONJ UNG PROC CLOCK L and H, and CONJ PROC CLOCK L and H. During a non-processor request (NPR) transaction, the NPR latency time is reduced by speeding up the B register shifting operations by decreasing the period of the CONJ PROC CLOCK L and H pulses from 300 ns to 150 ns. This is accomplished by asserting CONF FSHFT L at the input to E045. When this signal is low, the D-input to flip-flop E044 is always high so that the divide-by-2 function is not enabled. The periods of CONJ PROC CLOCK L and H are now the same as the period of the one-shot output which is 150 ns.

8.6 UNIBUS CONTROL

The Unibus control (BC) is found in prints CONC and CONC1, and the majority of Unibus drivers are found in print COND. The microprogram requests the BC to perform DATI, DATIP, DATO, and DATOB operations and to retrieve interrupt vectors. At the request of peripherals attached to the Unibus, the BC arbitrates BRs and NPRs. The BC is also responsible for detecting and causing a trap, whenever there is an attempt by the processor to address non-existent memory or to access odd addresses illegally.

The BC operates in parallel with the DP. The microprogram may request a DATI and then perform other tasks, such as incrementing R7, as long as the Bus Address Register is unchanged. The Unibus control proceeds with the DATI until the slave sync signal (SSYN) is returned from the slave device. At this point, the BC waits for the microprogram to set the CKOFF flip-flop shown on print CONC. This signal indicates that the microprogram is ready to accept Unibus data. If the microprogram sets CKOFF before SSYN is received, the BC inhibits the oscillator until SSYN is received or a Unibus timeout occurs.

8.6.1 DATI Timing

A DATI is used by the processor to retrieve data from devices attached to the Unibus. Figure 8-15 contains a timing diagram of the Unibus control signals for a DATI bus operation. Signals BBSY, C0, C1, and the address lines may be set by the processor or bus master, whenever it is determined that the Unibus is free for use. The Unibus is free for use by the processor when the following equation is true:

$$\text{BUS FREE} = (\sim\text{BBSY}) (\sim\text{NPR}) (\sim\text{SACK})$$

Once BBSY, C0, C1, and the address lines are asserted, the master device must wait at least 150 ns before issuing MSYN. During this time, the address and control lines of the Unibus are settling, so that when MSYN is issued, there will be no confusion regarding the device addressed or the direction of the data transfer. After MSYN is asserted, the BC must wait until SSYN returns from the Unibus and CKOFF is asserted. This indicates that data is available on the

Unibus and the microprogram is ready to accept that data. Once the processor has strobed the data from the Unibus into a storage element, normally the B register, the signal MSYN is not asserted. BBSY, C1, C0, and the address are maintained for 150 ns after MSYN is not asserted.

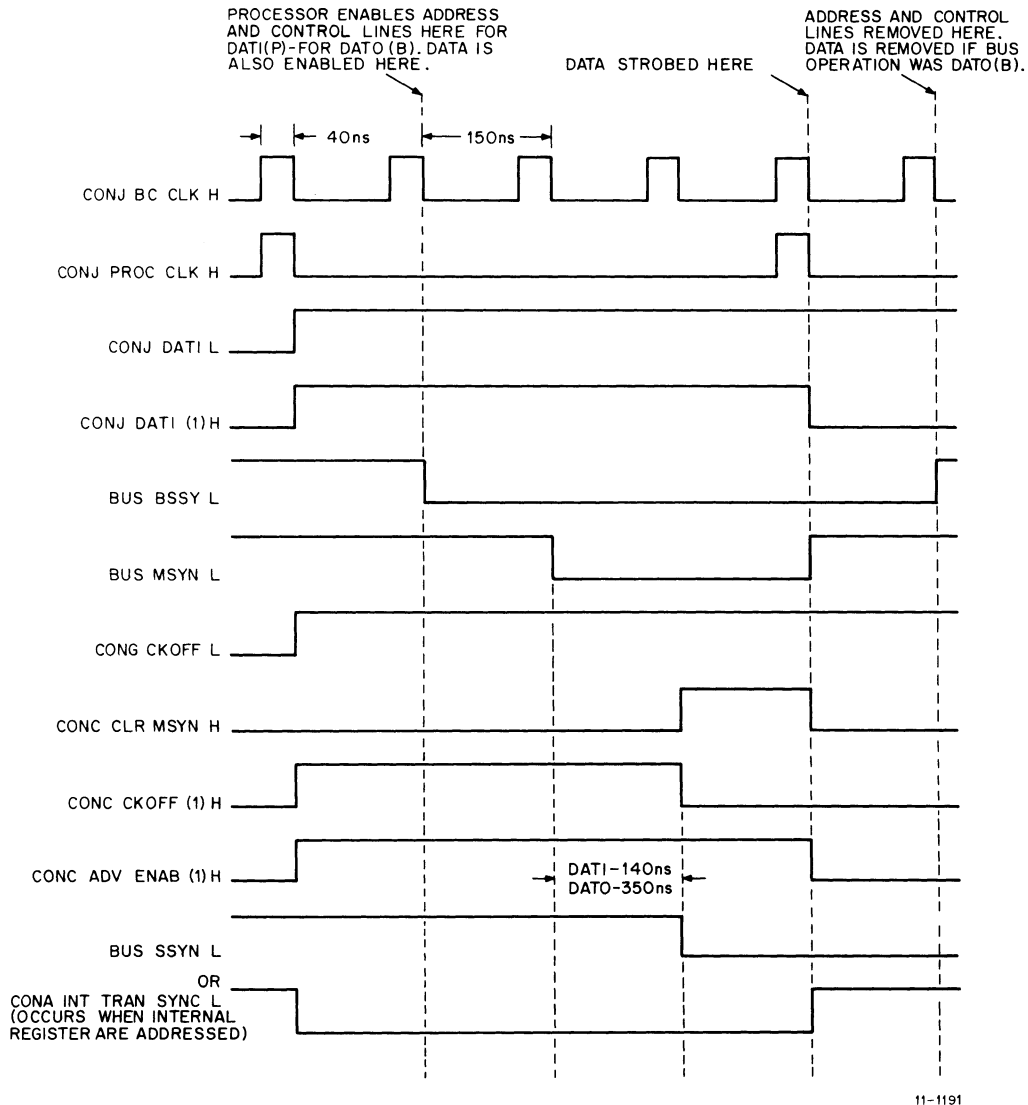

Figure 8-15 DATI and DATO Timing

8.6.2 DATI Operation

The microprogram requests a DATI by asserting the signal CONG DATI L, which is the input to E05309 on print CONC. On the next processor clock following the assertion of CONG DATI L, the flip-flop DATI E017 on CONC is set. If the Unibus is free, BBSY is set.

Simultaneous with the assertion of CONC BBSY (1) L, the bus address drivers (print COND) enable the contents of the Bus Address (BA) Register onto the Unibus address lines. The bus drivers for BUS A16 and BUS A17 are automatically enabled by the following equation:

$$\text{BUS A16 and BUS A17} = (\text{A15}) (\text{A14}) (\text{A13}) (\text{BBSY})$$

This allows PDP-11 processors, such as the KD11-B, that do not have extensive memory management facilities, to address peripheral registers that are located between 124K and 128K in the address space.

The MSYN flip-flop, E060 on print CONC, is normally set 150 ns after the issuance of BBSY. The setting of MSYN triggers a 9602 one-shot E025, shown at the lower left side of print CONC. This one-shot, which has a pulse width of 25 ns, is used to detect attempts at addressing non-existent memory by the processor. If SSYN does not appear on the bus before the signal CONC DAT TO (1) L is asserted by E034, the microprogram is forced to execute an error trap sequence.

SSYN is strobed into the holding register E005, shown on print CONC1, and generates the signal CONC SSYN (1) H. CONC SSYN (1) H enables an OR gate (E06208 shown in the center of print CONC). At this point, the following conditions exist:

- a. BBSY, C0, C1, and MSYN are being applied to the Unibus by the KD11-B.
- b. An address is enabled on the bus address lines by the processor.
- c. Data is being driven onto the Unibus data lines by the addressed device or memory location.
- d. SSYN is being generated by the addressed device.

The addressed peripheral device must maintain both its data and SSYN on the bus as long as MSYN is asserted. The Unibus control removes MSYN from the bus within 300 ns after SSYN and CKOFF are both set. The gating structure for removing MSYN can be traced back from the K-input to the MSYN flip-flop (E060 on print CONC).

If MSYN, CKOFF, and the oscillator divider flip-flop are all set, and the BC is waiting for SSYN, the oscillator input is inhibited and the oscillator stops. When SSYN is asserted, the input is released and MSYN is cleared. This method of synchronization causes no extra delay or flip-flop setup problem.

8.6.2.1 DATIP Operation – Note that the sequence for DATI and DATIP are almost identical. DATIP is used by the processor to prevent the modification of a memory location by a device other than the processor, while the processor is operating on that memory location. To further understand the need for DATIP, consider the operation of the DM11, a 16-line Asynchronous Serial Line Multiplexer (DEC-11-HOMA-D). The Buffer Active Register in the DM11 indicates status information and initiates message transmission. To begin the transmission of a message, the processor sets a 1 in the DM11 Buffer Active Register. When the message has been transmitted, the DM11 performs an NPR transfer to its own status register and clears the appropriate channel status bit.

Typically, the program to set an appropriate bit in the DM11 status register will use a BIS instruction. To execute this instruction, the processor must first execute a DATIP to the address of the DM11 status register and obtain a copy of the current contents of the status register. The specified bit is then set in the copy of the DM11 status register that is held by the processor. Finally, the processor performs a DATO to the status register and returns the altered copy of the status register to the DM11.

If, for instance, at the time of the DATIP, channels 0, 1, and 2 were active, the processor would retrieve a status word of 000007₈. Suppose the program desired to activate channel 4; the return status word would equal 000027₈. If channels 0, 1, or 2 completed their transmission between the time the processor issued the DATIP and the DATO and the processor permitted the DM11 to clear its status register before the DATO cycle of the BIS instruction, it is obvious that the copy of the DM11 status register held by the processor would be invalid.

Memories manufactured by DEC inhibit the normal restore cycle when a DATIP is issued. Therefore, when the following DATO is issued, the memory does not have to wait for the completion of the previous restore cycle before continuing with the DATO operation. However, the processor must inhibit NPRs from issuing a DATIP to the completion of the following DATO. Therefore DATIP operations lengthen the worst case NPR latency of the processor.

8.6.2.2 DATIP Logic – The BC executes a DATIP whenever the flip-flops DATI and DATIP (E017 and E008 on print CONC) are simultaneously set by the microprogram. The equation for setting DATIP, E017, is as follows:

$$(\text{SET DATIP E063, pin 12}) = (\text{CONG ENAB IN PAUSE L}) \leftarrow (\text{DPG ENAB NON MOD H})$$

$$(\text{CONI ALLOW PC L})$$

Signal number 1 is an indication that the microprogram anticipates the need for a DATIP. Signal number 2 confirms that the current instruction in the IR is one that requires the destination to be restored. The instructions TST, CMP, BIT, JMP, and JSR can never result in the modification of the destination by the processor. Therefore, it is not necessary to use the DATIP operation during the execution of these instructions. Signal number 3 ensures that DATIP is set on a processor clock rather than a BC clock. DATIP remains set following the transfer and inhibits the setting of NPG flip-flop E00712. It is directly cleared when the processor enables the destination data during the next DATO, and NPRs are again allowed to be granted.

8.6.3 DATO

DATO differs from DATI in that for a DATO the Unibus data lines are driven by the processor. Figure 8-14 shows that data is maintained on the bus for the duration of BBSY. In the KD11-B, a DATO operation requires cooperation between the BC and the microprogram. The steps executed by the microprogram for a DATO operation are illustrated in flow chart example shown below. Note that CK OFF and DATO must be set simultaneously, and that the microprogram control step that follows the DATO specification must enable the data from the appropriate storage register through the ALU and AMUX.

	LOC	NXT	
DATO Starts	334	065	D1–5 DATO; ALBYT; CKOFF /GET TO D1–6 FROM D0–18 VIA GOTO
DATA Put on Unibus	065	305	D1–6 DRIVERS B; GOTO B2-2 (BUT SERVICE)

The microprogram initiates a DATO operation by setting the DATO flip-flop (E017 on print CONC). The 7400 gate, E007, generates the signal CONC DAT ENAB L, which enables the data drivers shown on prints DPA, DPB, DPC, and DPD, and also clears DATIP.

8.6.4 Byte Operations

Byte operations have the following significance to the KD11-B Unibus control (BC):

- a. An odd address may be placed on the Unibus.
- b. For a DATOB, both C0 and C1 are enabled.

Byte operations have the following significance on the Unibus slave:

- a. No significance for DATIP operations.
- b. For DATOB operations, only the upper or lower eight bits of the addressed location should be altered.

NOTE

The master must properly position the data during a DATOB operation. For instance, if the operation is a DATOB to the odd byte of a location, the data must appear on Unibus data lines (15:08).

In the processor, the ALLOW BYTE flip-flop (E043 on print CONC) permits odd addresses and generates the appropriate C0 and C1 signals. The microprogram attempts to set the ALLOW BYTE flip-flop, whenever the possibility of a legal odd address or DATOB is anticipated, by asserting the signal, CONG ALLOW BYTE L. The signal DPG BYTE L (shown as an input to E06303 on print CONC) confirms that the current instruction (IR) is a byte operation.

8.6.5 Bus Errors

The following situations cause the bus error trap sequence to be executed:

- a. An attempt to illegally address an odd location in the memory space. For instance if the contents of R7 is odd at the beginning of an instruction fetch, a bus error trap will be executed because instructions must start at even addresses.
- b. An attempt to access non-existent locations in the memory space. A non-existent location is recognized when SSYN does not appear on the bus within 25 μ s of the setting of MSYN by the processor.

Either type of bus error causes the BE flip-flop, E050 on print CONC, to be set. The BE flip-flop inhibits the signal CONC MSYN OUT H which removes MSYN from the Unibus whenever a bus error is detected. The signal CONC BUS ERROR (1) H causes the 256 X 4 ROMs (E092 and E102 on print CONF) that generate the next address for the microprogram to be disabled. This forces the microprogram to execute its next control step from microaddress 010₈.

A double bus error is defined by two successive unsuccessful attempts at addressing the memory. On the second successive bus error, the microprogram is forced to location 110₈ by the simultaneous setting of the BE and DBE flip-flops (E050 and E060 on print CONC). The microprogram in the KD11-B is designed to cause a processor halt after two successive bus errors.

8.7 INTERNAL UNIBUS ADDRESSES

All presently implemented PDP-11 processors, including the KD11-B, contain internal registers that have associated addresses in the Unibus address space. To the program executed by the processor, the internal registers are indistinguishable from peripheral or memory registers. However, access to the internal registers is not available to devices attached to the Unibus other than the processor.

In the KD11-B, the concept of internal registers has been expanded to include the serial communications line control and the line clock. Table 8-9 lists the internal Unibus addresses.

Attempts to address internal Unibus addresses are detected by the logic detailed on print CONA and illustrated in Figure 8-16. A characteristic of all addresses listed in Table 8-9 is that the odd byte of the address is equal to 377₈. The signal CONA INT BUS ADDRS L, generated by E039, indicates that the odd byte of the currently addressed register is 377₈ and that the bus address may be that of an internal register.

The read-only memories of ICs E030, E069, and E068 decode the least significant eight bits of the Unibus address to determine which, if any, of the internal registers are currently being accessed.

Table 8-9
Unibus Addresses

Octal Address	Function
177700	} General registers R0 through R7
177701	
.	
.	
177707	} Hidden registers used by the microprogram
177710	
177717	
177776	
177570	Program status register
177570	Console switch register
177571	Odd byte of console switch register
177560	Receiver or keyboard status register
177562	Receiver or keyboard buffer
177564	Transmitter or printer status register
177566	Transmitter or printer buffer
177546	Line clock status register

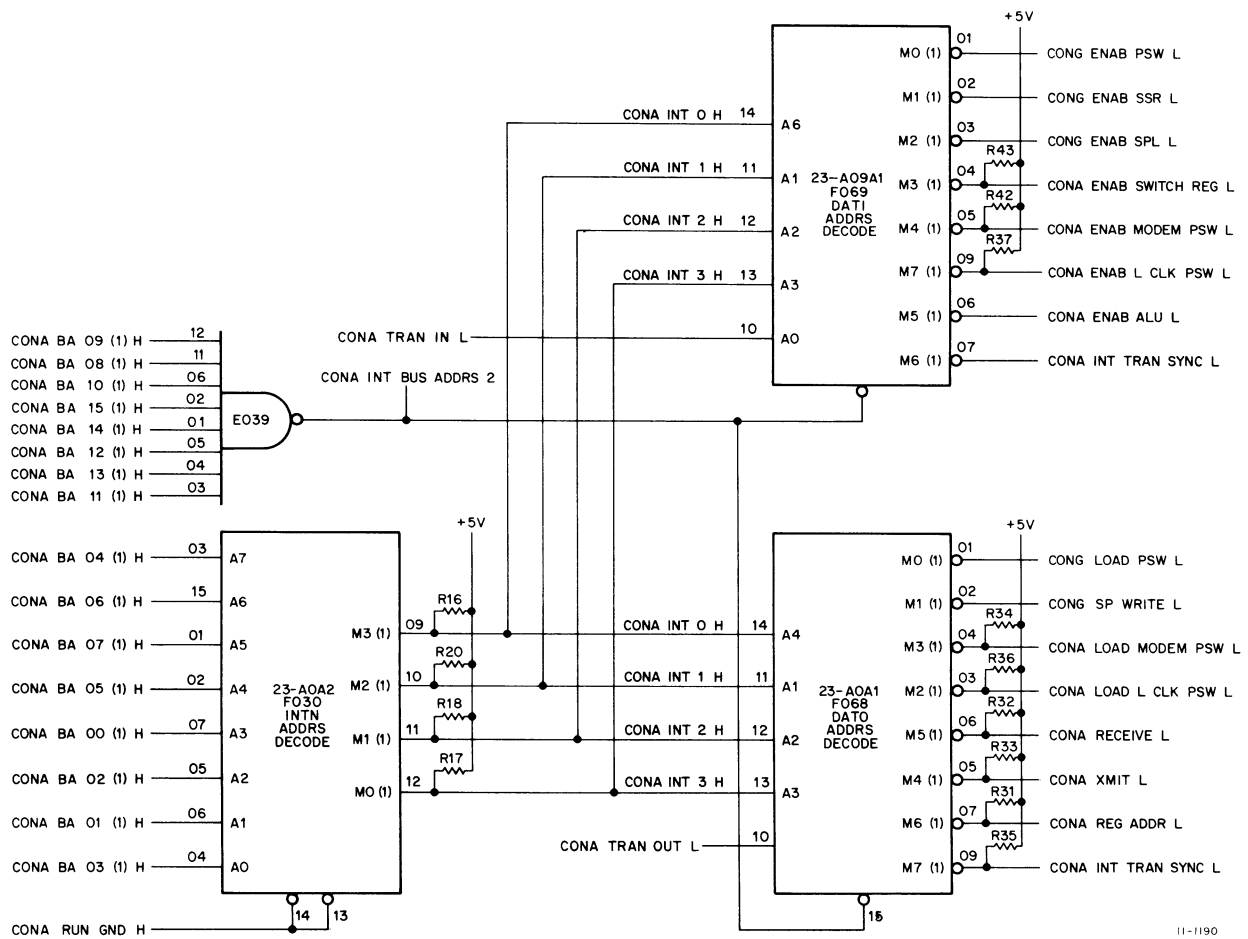
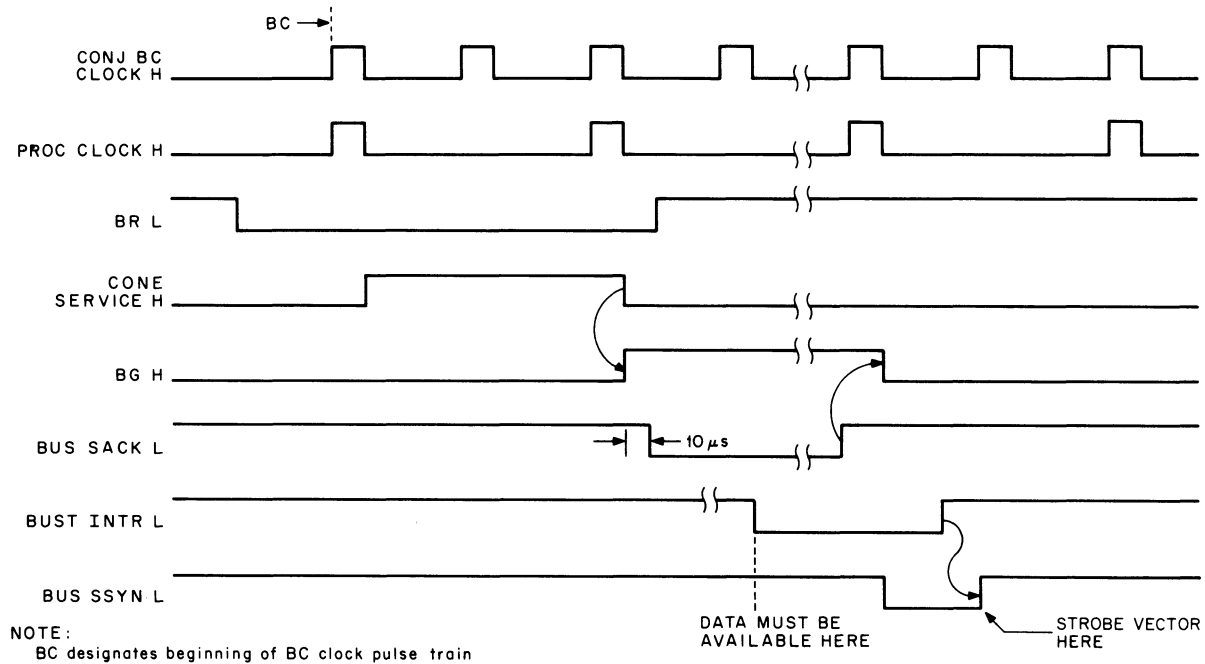

Figure 8-16 Unibus Address Decoding

The timing diagram contained in Figure 8-17 shows that the signal CONA INT TRAN SYNC L replaces SSYN for internal registers. Note that bus addresses, C1, C0, and MSYN are driven onto the Unibus during attempts to address internal registers. However, the signals generated by ROMs E068 and E069 reconfigure the data path (DP) such that during a DATI from 177776, for example, the PSW is enabled onto the DP.



11-1188

Figure 8-17 Bus Request (BR) Timing

During transfers to and from the processor, to registers and to memory, data to or from the BREG is normally inhibited. The reason is that most of the elements contained on the A-leg may be addressed with their corresponding Unibus address. Therefore, almost any data transfer may be from or to the DP. Since it is not possible to both read and write into the DP on the same clock pulse, it is necessary for the microprogram to receive and transmit Unibus data from the BREG.

In order to understand the decoding sequence for ROMs F030, F068, and E069, it is necessary to refer to the ROM maps (K-RL-M7260-8 and K-RL-M7261-8).

8.8 BUS REQUESTS

The KD11-B responds to bus requests (BRs) in a manner similar to that of the other PDP-11 processors. Peripherals may request the use of the Unibus in order to make data transfers or to interrupt the current processor program by asserting a signal on one of four BR lines, numbered 4, 5, 6, and 7 in order of increasing priority. For example, if two devices, one at priority 5 and the other at priority 7, assert BRs simultaneously, the device at priority 7 is serviced first. Furthermore, if the processor priority, determined by (07:05) of the PSW, is at level 4, only devices that request BRs at levels higher than 4, such as BR 7, BR 6, or BR 5, are serviced. Table 8-10 contains the order of priorities for all BRs and other traps.

**Table 8-10
Trap Priorities**

Priority	Service Priorities
Highest	1. T-bit trap 2. Stack overflow 3. Power fail 4. BR7 5. BR6 6. Internal line clock 7. BR5 8. BR4 9. UART receive 10. UART transmit 11. Console stop
Lowest	12. Next instruction fetch

Since a BR can cause a program interrupt, it may be serviced only after the completion of the current instruction in the IR. A device that requests a program interrupt must at the appropriate time place a vector address on the Unibus data lines. The processor first stacks away the current contents of PSW and R7; then a new R7 is loaded from the contents of the vector address, and a new PSW is loaded from the contents of the vector address plus two. An example of the flow that handles a BR is as follows:

```

LOC    NXT    *BUS GRANT SERVICE
                /GET TO BG-1 FROM BUT SERVICE

040    305    BG-1 BUT INTERRUPT; GO TO B2-2 (BUT SERVICE
                ↓                /IF INTERRUPT GO TO INT-1
                /IF NO INTERRUPT FALL THROUGH TO B2-2

LOC    NXT    *INTERRUPT SERVICING
                /GET TO INT-1 FROM BG-2 VIA BUT INT (TRUE)

325    246    INT-1 R(12) ← UNIBUS DATA; SET SLAVE SYNC; GO TO ET-3
                ↓

LOC    NXT
246    247    ET-3 B, BA ← R(6) - 2; ENAB OVER
247    226    ET-5 R(6) ← B; CK OFF; DATO
226    251    ET-6 DRIVERS ← PS
251    252    ET-7 B, BA ← R(6) - 2; ENAB OVER
252    253    ET-8 R(6) ← B; CK OFF; DATO
253    254    ET-9 DRIVERS ← PC
254    255    ET-10 BA ← R(12); DATI; CK OFF
255    256    ET-11 PC ← UNIBUS DATA
256    257    ET-12 BA ← R(12) + 2; DATI, CK OFF
257    305    ET-13 PS ← UNIBUS DATA; GO TO B2-2 (SERVICE)
  
```

The microprogram indicates the end of instruction execution by asserting the signal CONE BUT SERVICE L. BRs are arbitrated by the ROM E012 (shown on print CONC1). If there is an impending BR, the signal CONC BR GRANT H is asserted by E02208 (print CONC1). When CONE BUT SERVICE L is issued, the appropriate BG is clocked into the storage register (E021). Simultaneously, the microprogram address is forced to the bus grant sequence by the logic shown on print CONE.

In the KD11-B, interrupts for the SCL and the line clock are not entered the same way as interrupts from other devices attached to the Unibus. Interrupts from the SCL and line clock are handled in the same manner as power fail and stack overflow traps. For all of these events, the microprogram address is altered when CONC BUT SERVICE L is issued to force the microprogram into the appropriate routine, which simulates the appropriate interrupt or trap.

The appropriate vector address for SCL and line clock interrupts are generated by the constants generator, which is the E025 ROM shown on print DPB.

8.9 NON-PROCESSOR REQUESTS (NPR)

NPRs are a facility of the Unibus that permit devices on the Unibus to communicate with each other with minimal participation of the processor. The processor's function in servicing an NPR is simply to give up control of the bus in a manner that does not disturb the execution of an instruction by the processor. For example, the processor may not relinquish the bus following a DATIP.

An NPR is received through a bus receiver (print COND) and clocked into storage register E005 (print CONC1). If conditions are appropriate to permit an NPG to be issued by the KD11-B, the signal CONC SET NPG H is issued by E01406. CONC SET NPG H is generated according to the following equation:

$$\text{CONC SET NPG H} = (\leftarrow \text{DATIP}) \cdot (\leftarrow \text{SACK DELAYED}) \cdot \text{RUN}$$

The signal CONC SET NPG H causes flip-flop E033 to be set, which in turn causes NPG to be placed on the Unibus. Note that both NPGs and BGs will be issued by the KD11-B for a period of 10 μs . If the requesting device does not respond with SACK within this period, the 9602 timer IC (shown in the upper right-hand corner of CONC1) trips, causing flip-flop E034 to be set. This in turn causes the pending BG or NPG to be cancelled, and the processor to continue operation.

8.10 SERIAL COMMUNICATIONS LINE DESCRIPTION (SCL)

The SCL of the KD11-B is essentially program compatible with the KL11 teletype control. The heart of the serial communications line logic (prints DPH and DPH1) is the Universal Asynchronous Receiver Transmitter (UART), an MOS-LSI IC. The UART is easily recognized on the M7260 module because it is the only 40-pin dual in-line package used in the KD11-B. The UART is the only IC in the processor that requires two supply voltages, +5V and -12V. The -12V supply (print DPH) for the UART is generated by placing four diodes in series with the -15V supplied by the power supply.

The additional circuitry other than the UART (prints DPH and DPH1) serves the following purposes:

- a. Generation of the reader RUN signal that is used to control the low speed paper-tape reader found on Model ASR 33 Teletypes.
- b. Generation of status bits and interrupts to make the KD11-B SCL program compatible with the KL11.
- c. Generation of the 20-mA current loop necessary to operate Model ASR 33 Teletypes, VT05s, and LA30s.

An important feature of the KD11-B SCL is double buffering. An understanding of double buffering (Figure 8-18) may be gained by studying the programming example provided. In order to receive or transmit data at the maximum rate, it is only necessary to empty or fill the appropriate UART buffer once every character time. Conversely, on single-buffered devices such as the KL11, it is necessary to empty or fill the appropriate buffer in one bit time.

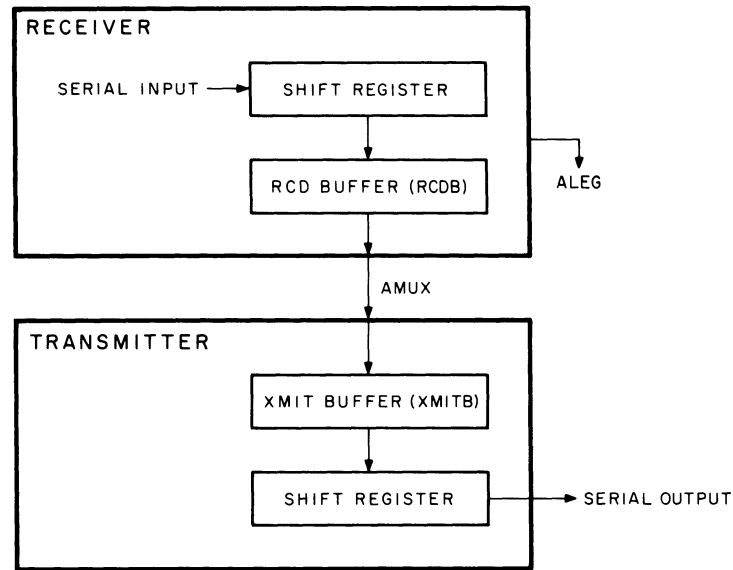

11-1189

Figure 8-18 Double-Buffering Data Flow

The following programs are sample programs which utilize the UART. The first program simply echoes a character received from the UART into the transmitter of the UART. The second program illustrates the proper use of the RESET instruction, following an instruction that caused the SCL to transmit a character. RESET should not be issued until the last desired character has cleared the UART transmitter shift register.

UART Sample Programs

```

LOOP:  TSTB   RCDSTA      ; Test for a received character
       BPL           ; Go to Loop if no character
       TSTB   XMITST    ; Test the XMIT condition
       BPL
       MOVB   RCDB, XMIT ; echo character
                               ; If at this point it is desirable to issue a
                               ; RESET it is necessary to send a null
                               ; character to ensure that the desired
                               ; character has been completely transmitted

       TSTB   XMITST
       BPL
       MOVB   NULL, XMIT
       TSTB   XMITST    ; When null character is
       BPL           ; clear of the
       RESET          ; XMITB
  
```

On print DPH, the transmitter DONE flag is seen only as an indication that the transmitter buffer is empty (TBMT). The TBMT flag will set at least one character time before the UART has finished transmitting the last character received. A RESET instruction that occurs while a character is in the process of being transmitted aborts that character transfer. Therefore, the only safe way to issue RESET instructions, following an instruction that has transmitted a character through the UART, is to transmit a null character prior to issuing the RESET instruction. Some care must be used in selecting the null character since it may be garbled by the RESET instruction. When the

null character clears the UART transmitter buffer, it is safe to issue the RESET instruction. When the SCL maintenance mode is enabled by setting the transmitter status bit (2), the serial output is fed back into the serial input just as in a standard KL11. The transmitter status register address is 177564₈. The SCL always appears to the program as the last device at the BR4 interrupt level.

There is a provision in the SCL control (print DPH) to disable the internal clock and to provide an external clock for the UART. External clocks consisting of TTL-compatible signals must be square waves of up to 160 kHz. The clock frequency must always be 16 times the SCL baud rate.

8.11 LINE CLOCK

8.11.1 Introduction

The line clock allows the program to measure time by sensing the frequency (50 Hz or 60 Hz) of the ac input power. The sensing signal is generated by the power supply. It is a positive, approximate square wave developed from the ac input waveform. For a 60-Hz supply, this signal occurs at a rate of 16.7 ms; the rate for a 50-Hz supply is 20 ms. Each sensing signal generates a flag that can be read on Unibus data bit 07 and can be cleared only by program control. A line clock interrupt signal is generated concurrent with the flag signal, provided the interrupt enable bit is set by the program. This interrupt signal is used in the processor priority arbitration logic. An interrupt enable flag is generated and can be read on Unibus data bit 06.

The line clock is not connected to the Unibus. It uses an internal bus and can be accessed only by the processor and console; however, to the operating program, the line clock is indistinguishable from other devices that are attached to the Unibus. This is accomplished by logic that decodes the address of the line clock on the Unibus as an internal address.

The line control logic is shown in print CONI. It can be divided into two sections: flag control and interrupt control. Each section is described in detail in subsequent paragraphs.

8.11.2 Flag Control

The flag control logic is shown in the top of print CONI. Signal PWR SUPPLY L CLK INT H is the sensing signal from the power supply. This signal is generated by a resistor-Zener clipper circuit. The positive half cycle is clipped at approximately +4V and the negative half cycle is clipped at approximately -1V. This produces a clipped sine wave (approximate square wave) with a pulse height of nearly +5V (base line at -1V). These positive pulses occur every 16.7 ms for a 60-Hz input and every 20 ms for a 50-Hz input.

Signal PWR SUPPLY L CLK INT H is sent to the input of NAND Schmitt trigger E019. Each positive input is converted to a clean negative square pulse at the output. The positive-going edge of this pulse clocks the CLOCK flip-flop E036. This is a redefined flip-flop with its D-input connected to ground (CONH RUN GND L). When clocked, the flip-flop is set and its 1-output (pin 06) is high. This signal is sent to the input (pin 02) of Unibus driver E03. The output of this driver is the line clock flag signal BUS D07L. It can be read during a DATI operation by providing an enabling signal to pin 03 from gate E067. This gate is enabled when both inputs are low. The inputs are: CONC BBSY (1) L which is asserted when the BBSY flip-flop E043 (print CONC) is set; and CONA ENAB L CLK PSWL which is generated by DATI ADDR5 DECODE ROM E069 (print CONA).

The flag can be cleared only by program control. It is accomplished by signal CONI CLR CLOCK L via the clear input (pin 04) of the CLOCK flip-flop. This signal is generated at the output (pin 03) of NAND gate E027. One input of this gate is the inversion of DPB AMUX 07 H via gate E065 pin 12. The other input to E027 is the result of ANDing CONA LOAD L CLK PSWL and CONJ PROC CLOCK L. Signal CONA LOAD L CLK PSW L is generated by DATO ADDR5 DECODE E068 (print CONA). It is low when the line clock address is decoded. When this signal is ANDed with a low clock pulse (CONJ PROC CLOCK L), input 02 of E027 is high. If the flag is to be cleared, the program generates a low on DPB AMUX 07 H. This signal is inverted and places a high on pin 01 of E027. The output (pin 03) of E027 is CONI CLR CLOCK L, which is low, and the CLOCK flip-flop is cleared.

8.11.3 Interrupt Control

The interrupt control logic is shown on the bottom of print CONI. The Schmitt trigger output also clocks LC INT flip-flop E08 which is a redefined flip-flop with its D-input connected to ground (CONH RUN GND L). When clocked, the flip-flop is set and its 1-output (pin 06) is high. This signal is sent to the D-input of LC INT SYNC flip-flop E018. This flip-flop is clocked by CONJ PROC CLOCK L. When clocked, the 1-output of the LC INT SYNC flip-flop is high. This signal is sent to pin 05 of NAND gate E027. This gate generates signal CONI L CLK INT L that is used in the processor priority arbitration logic. It can be regarded as an internal BR signal. Signal CONI L CLK INT L is asserted when both inputs (pins 04 and 05) are high. Pin 05 is high as discussed above and pin 04 is high when the program sets the interrupt enable bit and the processor priority is not 6 or 7. The logic for qualifying pin 04 is discussed below.

The high output (pin 01) of E026 is inverted by NAND gate E045 pin 08 and used to clock INT ENAB flip-flop E035. To set the interrupt enable bit, the program generates a high on DPB AMUX 06 H which is the D-input of the INT ENB flip-flop. When clocked, the INT ENB flip-flop is set and its 0-output (pin 08) is low. This signal is sent to pin 11 of gate E026. The other input of this gate comes from the output of NOR gate E049 which is low when either or both of its inputs are high. The inputs are DPE PSW 07 (0) H and DPE PSW 06 (0) H. They come from the 0-outputs of PSW (07:04) flip-flop E042 (print DPE). This flip-flop stores the current priority of the processor in bits 07, 06, and 05. The two outputs used are the complement of bits 07 and 06 of the priority word. The qualifying condition for the interrupt control logic is that the processor priority not be 6 or 7. That is, the output of gate E049 is low when the processor priority is not 6 or 7. This condition is verified as shown below.

Priority Bits DPB AMUX 07 H, 06 H and 05 H to PSW (07:04) flip-flop				Complement of Bits 07 and 06 from PSW (07:04) flip-flop		
Priority	PSW Bits			07	06	
	07	06	05			
7	1	1	1	0	0	} NOR Gate E049 Disabled (Output High)
6	1	1	0	0	0	
5	1	0	1	0	1	} NOR Gate E049 Enabled (Output Low)
4	1	0	0	0	1	
3	0	1	1	1	0	
2	0	1	0	1	0	
1	0	0	1	1	1	
0	0	0	0	1	1	

The low output of NOR gate E049 is sent to input pin 12 of E026. The other input is low because the INT ENAB flip-flop is set. This generates a high at the output of E026 (pin 13) which is sent to pin 04 of E027. The other input (pin 05) of E027 is also high which asserts CONI L CLK INTL.

The 1-output of INT ENAB flip-flop E035 is sent to pin 06 of Unibus driver E03. The output of this driver is the state of the interrupt enable bit; however, it is designated BUS D06L. This bit can be read during a DATI operation by enabling the gate with the output of E067, which is explained in the flag control discussion.

When the interrupt is serviced, the microprogram performs a BUT SERVICE which asserts signal CONE L CLK SER L from the INT INTR ACK ROM (E090 print CONE). This low signal is gated with a low clock pulse (CONJ PROC CLOCK L) at pins 09 and 08 of E026 to produce a high output (pin 10). This high is sent to pin 06 of NOR gate E026 where it is inverted and used to clear the LC INT flip-flop via its clear input (pin 10). When the LC INT flip-flop is cleared, it sends a low signal to the D input of the LC INIT SYNC flip-flop. On the next clock pulse (CONJ PROC CLOCK L), the LC INT SYNC flip-flop is reset and the interrupt signal CONI L CLK INT is cleared.

Some programs assert the interrupt enable bit and keep it asserted. In the case of the line clock, the interrupt signal CONI L CLK INT L cannot be asserted even if the INT ENAB, LC INT, and LC INT SYNC flip-flops are set as long as the processor priority is 6 or 7. If the priority is lowered below 6 with these flip-flops set, CONI L CLK INT L could be asserted. This possibility is circumvented by clearing the LC INT flip-flop every time the program clears the CLOCK flip-flop in the flag control section. This is accomplished by CONI CLR CLOCK L which is generated at E027 pin 03 and is sent to the clear input (pin 10) of LC INT flip-flop E018 via gates E041 and E026.

The CLOCK flip-flop and LC INT flip-flop are also directly cleared by CONC BUS INIT L which is generated during the power-up sequence, during a RESET instruction, or when the console START switch is depressed.

8.12 POWER FAIL

The KD11-B power fail/auto restart circuitry (print CONH) serves the following purposes:

- a. Initializes the microprogram, the Unibus control (BC), and the Unibus to a known state immediately after power is applied to the computer.
- b. Notifies the microprogram of an impending power failure.
- c. Prevents the processor from responding to an impending power failure for 2 ms after initial startup.

The actual power fail/auto restart sequences are microprogram routines. The operation of the power fail/auto restart circuitry depends on the proper sequencing of two bus signals: AC LO and DC LO. Because of the electrical properties of the Unibus drivers and receivers, the entire computer system must be powered up for the machine to operate. Therefore, the processor is notified of a power fail in peripherals as well as in its own ac source.

The notification of power status of any PDP-11 system component is transmitted from each device by the signals BUS AC LO L and BUS DC LO L (Figure 8-19). The power-up sequence shows that BUS DC LO L is unasserted before BUS AC LO L is unasserted. When BUS DC LO L is not asserted, it is assumed that the power in every component of the system is sufficient to operate. When BUS AC LO L is not asserted, there is sufficient stored energy in the regulator capacitors of the power supply to operate the computer for 5 ms, should power be shut down immediately.

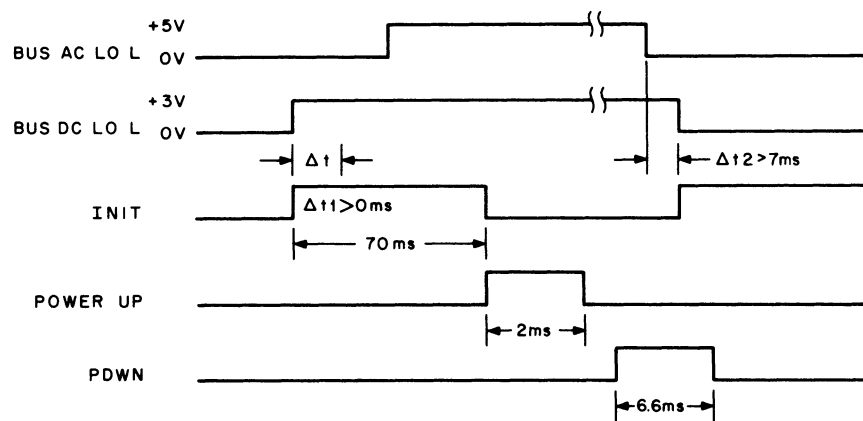

11-1187

Figure 8-19 BUS AC LO and BUS DC LO Timing Diagram

As power is shut down, note that BUS AC LO L is asserted first. BUS AC LO L is an indicator that warns the processor of an impending power failure. When BUS DC LO L is asserted, it must be assumed that the computer system can no longer operate predictably. Memories manufactured by DEC use BUS DC LO L as a switch signal. When BUS DC LO L is asserted, these memories turn themselves off even if power is available. Time $\Delta+2$ (Figure 8-19) is the time delay between the assertion of BUS AC LO L and the assertion of BUS DC LO L; it must be greater than 7 ms. This allows for power to be rapidly cycled on and off. According to PDP-11 specifications, upon system startup, a minimum of 2-ms run time is guaranteed before a power fail trap occurs, even if the line power is removed simultaneously with the beginning of the power-up sequence. After the power fail trap occurs, a minimum of 2-ms run time is guaranteed before the system shuts down. Given the tolerances permitted in the timing circuitry used in most equipment, $\Delta+2$ must be greater than 7 ms.

When an impending power fail is sensed, a program trap occurs that causes the present contents of R7 and the PSW to be pushed onto the memory stack, as determined by the contents of R6. R7 is then loaded with the contents of memory location 24₈, and the PSW is loaded with the contents of location 26₈. Processing is continued with the new R7 and PSW. The program must prepare for the impending power failure by storing away volatile registers and reloading location 24₈ and 26₈ with a power-up vector. This vector points to the beginning of a restart routine.

When power is restored, the processor loads R7 with the contents of location 24₈ and the PSW with the contents of location 26₈. Note that no stacking is performed on an auto restart. The HALT switch is also ignored if the console lock is set. After loading R7 and the PSW, processing continues if the HALT switch is not depressed. Presumably, the program will prepare locations 24₈ and 26₈ for another power failure. If the HALT switch is depressed and the console lock is not enabled, the processor powers up in the halt state.

Schematics of the power fail, auto restart, and bus reset logic are found on print CONH. As shown on Figure 8-18, E07106 generates a 70-ms processor INIT pulse as soon as BUS DC LO L is nonasserted after power is applied to the computer. At the end of 70 ms, the PUP one-shot, IC E08209, is fired if BUS AC LO L is not asserted. At this point, the processor begins to load R7 and the PSW if the HALT switch is not depressed. The PUP one-shot generates a 2-ms pulse, during which time the assertion of BUS AC LO L is not recognized.

After PUP has been reset, the assertion of BUS AC LO L fires the one-shot E08206. Flip-flop E09708 is set by the leading edge of the one-shot's pulse. Note that E09708 is not synchronized to the processor clock. Flip-flop E09706 generates the signal CONH PDWN SYNC (1) L, which is synchronized to the processor clock. A power fail trap can be recognized by the microprogram whenever CONE BUT SERVICE L is issued. The various traps are arbitrated by the ROM F101 (print CONE).

If a momentary power failure occurs which causes the assertion of BUS AC LO L but does not cause the assertion of BUS DC LO L, the processor will restart when the PDWN (0) L one-shot times out, retriggering the INIT one-shot simultaneously with DC LO H becoming nonasserted.

CHAPTER 9

MICROPROGRAM CONTROL

9.1 INTRODUCTION

This chapter describes the microprogram control implemented in the KD11-B processor. The flow notation used in the microprogram flow section of the prints is described in Paragraph 9.5.1. The difference between microprogram control and conventional control in a computer processor is described in Paragraph 9.2. Paragraph 9.3 describes the KD11-B control store (CS) structure; Paragraph 9.4 describes the technique of branching within microroutines in the CS; and Paragraph 9.5 describes the microprogram flow, including instruction interpretation, Unibus control coordination, interrupts, traps, and console functions.

9.2 MICROPROGRAMMED VERSUS CONVENTIONAL CONTROL

The control section of a conventional computer is a complex collection of specialized logic circuits. These circuits generate the timing signals that constitute the major and minor time states of a machine cycle. During each time state, these control signals configure the data path (DP), determine function performed within the arithmetic/logic units (ALU), influence the Unibus control (BC), etc. Major disadvantages associated with this conventional approach are its complexity, the large amount of logic required, its inflexibility, and difficulty of making modifications.

A microprogrammed processor such as the KD11-B results in a reduction in the amount and complexity of the control logic, while facilitating a systematically implemented and easily modified control section. Basically, a microprogram involves the execution of a sequence of microsteps from the control store (ROMs). Execution of a microstep causes the assertion of a set of control signals specified in the control store word associated with that microstep. By executing appropriate sequences of microsteps (known as a microroutine), the KD11-B can be made to interrupt PDP-11 instructions. Other functions such as console functions, interrupts, and traps are also accomplished by specialized microroutines.

9.3 CONTROL STORE

Figure 9-1 shows the format of the KD11-B control store (CS) word. There are 256 such words, each having the same fields. The fields, the possible values they may contain, and the significance of each value are described in Table 9-1. The CS is shown on prints CONF and CONG.

An explanation of the notation will aid in relating the CS word to the reset of the print set. Each field within the CS has been given a name (e.g., BUT, BRG, ALG, . . . ,ALU, NXT). These field names are used throughout documentation of the microprogram.

The signal coming from each bit is named according to the convention used in the print set. Note that several signals may be associated with a single field (e.g., the BUT field controls four signals: CONG BUT 01 L, CONG BUT 00 L, CONG BUT 02 L, and CONG BUT 03 L).

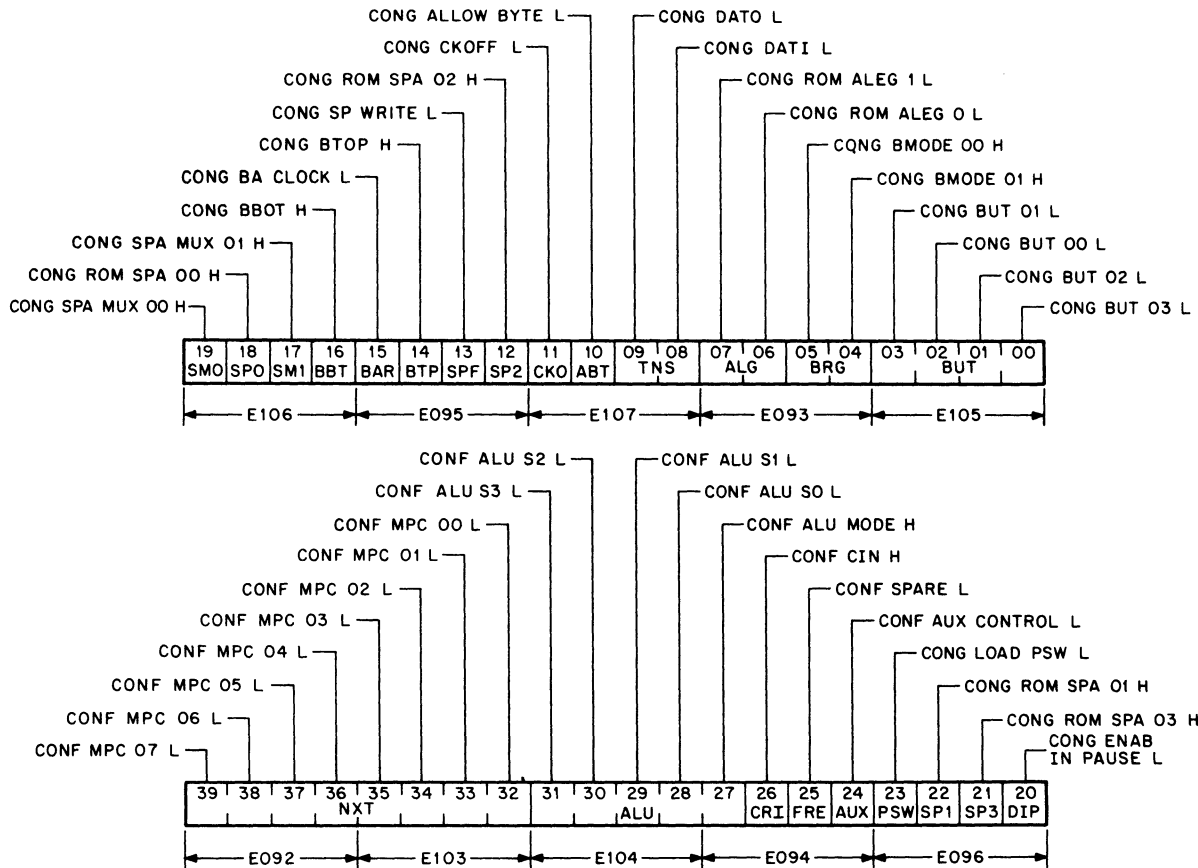

11-1216

Figure 9-1 Control Store Word Bit and Field Format

Table 9-1
KD11-B Control Store Fields

Field	Description
BUT	<p>Branch on microtest. The BUT field has two uses: a) specify microprogram conditional branches, and b) as an encoded miscellaneous field. The values this field can assume are grouped by these two uses.</p> <p>Branching within the microprogram is accomplished by wiring conditional signals with the open-collector outputs of the NXT field of the CS. Each BUT condition has the minimum number of control bits required. This makes the range of branching restrictive, but it minimizes logic (print CONE). Table 9-2 lists the microstep in which each BUT is performed, the possible conditions, and resulting destination of the microprogram branch.</p> <p>Microprogram conditional branches:</p>
NON	No effect

Table 9-1 (Cont)
KD11-B Control Store Fields

Field	Description
BUT (Cont)	JSRMP Microprogram branch on JMP or JSR instruction
	IRD Microprogram branch on results of Instruction Register Decode
	BYT Microprogram branch to distinguish: a) byte and non-byte instructions, and b) odd/even byte references
	DST Microprogram branches on destination mode IR (5:3)
	MOV Microprogram branch to distinguish both MOV and MOVB from other instructions
	INT Microprogram branch on interrupt to be processed
	UNY Microprogram branch to distinguish unary instructions
	SW Microprogram branch dependent on console switch action
	NMD Microprogram branches to distinguish non-modifying instructions (e.g., CMP, TST, etc.)
	SRV Microprogram branch at end of instruction sequence to determine if any condition requires service before going off to fetch next instruction
	Miscellaneous encoded field:
	CON Enable the constants ROM on the A-leg
	INI Trigger BUS INIT L during the RESET instruction
	SVS Set SSVN on Unibus during the interrupt sequence
	ENO Enable the stack overflow detection logic
	IRC Clock data into the instruction register
BRG	Control the B register
	H Hold, do not modify.
	L Load.
	SR Shift right once.
	SL Shift left once.
ALG	A-leg control; determines what is enabled onto the A-inputs of the ALU

Table 9-1 (Cont)
KD11-B Control Store Fields

Field		Description
ALG (Cont)	SP	Scratch pad
	NUL	Nothing
	SPR	Low orders eight bits (right half) of the scratch pad
	PSW	Program Status Word
TNS		Initiation of Unibus transfer
	NON	No effect
	I	Initiate DATI
	O	Initiate DATO
ABT	IP	Initiate DATIP
		Allow byte reference on current Unibus transfer.
	NO	
CKO	YES	
		Inhibit the processor clock until pending Unibus transfer is complete.
	OFF	No effect
SPA	ON	
		Scratch pad address. This field is physically split in the control store word. It is made up of: SPA = SP0 = CS (18) SP1 = CS (22) SP2 = CS (12) SP3 = CS (21)
		Scratch pad address (R0 through R17)
SPF		Scratch pad control function
	REA	Scratch pad contents not modified
	WRI	Write into scratch pad
BLG		B-leg control. Determines what is enabled onto the B-input of the ALU. This field is physically split in control store word.

Table 9-1 (Cont)
KD11-B Control Store Fields

Field	Description
BLG (Cont)	BLG = BTP (B Top - Upper Byte) = CS (14) BBT (B Bottom - Lower Byte) = CS (16)
BRG	B register
SEX	B register sign extended. Bit 7 of the B register is propagated from bit 7 to bit 15.
+1	The constant
BAR	Bus Address Register Control
H	Hold, do not modify.
L	Load.
SAM	Scratch pad address multiplexer control. This field is physically split in the control store word. SAM = SM0 (19) SM1 (17)
ROM	Scratch pad address taken from control store word (see SPA field)
IRS	Scratch pad address taken from source register bits of Instruction Register, IR (8:6).
IRD	Scratch pad address taken from destination register bits of Instruction Register, IR (2:0).
BAR	Scratch pad address taken from Bus Address Register low order three bits, BA (2:0).
PSW	Program Status Word control
H	Hold
L	Load
AUX	Auxiliary ALU control enabled
OFF	
ON	
CRI	Enable carry in to ALU
OFF	
ON	

Table 9-1 (Cont)
KD11-B Control Store Fields

Field	Description
ALU	ALU function
AL	A logical
AA	A arithmetic
AB	A and B
ABBAR	A and ones complement of B
ZERO	Output zero
A OR B	A or B
BL	B logical
A + B	A plus B
AXORB	A exclusive or B
A-B-1	A minus B minus 1
BBAR	1's complement of B
-1	Output the constant minus one
A-1	A minus one
ABAR	1's complement of A
ASL	Arithmetic shift B left
ROL	Rotate B left
ASR	Arithmetic shift B right
ROR	Rotate B right

These are used during shift and rotate instructions to control the serial shift inputs to the B register.

A field may contain any one of a number of different alternative bit patterns. To facilitate microprogramming, these alternatives have been given symbolic names, making it possible to work with the microprogram at a symbolic level rather than in binary. For example (Table 9-1), one of the alternative values that can be assigned to the ALU field is OR (A or B). This value corresponds to a bit pattern of 01001 [CS (37:33) = 01001].

The data word output from the CS is determined by the contents of the MPC registers (E091 and E102 shown on print CONF).

9.4 BRANCHING WITHIN MICROROUTINES

A microroutine is composed of a sequence of microsteps. Every microstep specifies the location of the next microstep in a sequence, namely, the NXT field. During the execution of a microstep, the signals resulting from the NXT field are loaded into the MPC (microprogram counter). The MPC specifies the location from which the next microstep will be executed (print CONF). Conditional branching within a microroutine is accomplished by wire-ORing signals into those signals coming from the NXT field, while they are being loaded into the MPC. Each branch condition controls the minimum number of bits required. This restricts the range of branching, but it minimizes the logic (print CONE). This provides control for all the bits in the MPC. Table 9-2 shows the location of each microcode branch, the destination, and associated conditions.

In general, microsteps are not executed from numerically sequential locations. This extra degree of complexity (and an extra eight bits in each CS word to specify the NXT location) enables the minimization of logic.

Table 9-2
Microprogram Branches (BUT)

BUT	Source	Destination	Comment
IRD (IR decode)	F-5	S0-1 through S7-1	All double operand instructions
		D0-1 through D7-1	Single operand instructions
		B-1	Branch, change PC
		B2-2D	Branch, PC unchanged
		MCC-1	Set or 0 clear condition codes
		R1-1	RTS
		R2-1	RTI
		W-1	WAIT
		H-1	HALT
		ET-1	EMT
		BT-1	Break Point Trap
		IT-1	IOT
		T-1	Trap
		RT-1	Reserved instruction
RST-1	RESET		
DST (destination)*	S0-2, SBE-2	D0-1 through D7-1	
		CCM-2	Clear condition codes
	SC-1	Set condition codes	

*Always have a branching destination (i.e., NXT field always modified).

Table 9-2 (Cont)
Microprogram Branches (BUT)

BUT	Source	Destination	Comment	
BYT (byte)	S0-1	SBE-1	Byte source data (Mode 0)	
	S1-2	SBE-1	Even byte source data	
		SBO-1	Odd byte source data	
MOVE	D0-1	DBO-1	Byte instruction other than MOVE	
		MB-0	MOVB instruction (BYTE)	
		D0-3A	MOV instruction (NOT BYTE)	
NMD (non-modifying)	D0-3, D0-3A	B2-2A	Non-modifying instruction TST, CMP, Bit	
		D1-4		B2-2B
		DBO-2		B2-2
		DO-10		B2-2C
SRV (service)	B-3, B2-2 B2-2A, B2-2B B2-2C, B2-2D, CC-1, CS-3, D0-4, DB0-3, J1-2, J2-8, MB-2, SC-1		In order of priority highest to lowest	
		BT-1	T-bit trap	
		ERT-IA	Stack overflow trap	
		PF-1	Power fail	
		BG-1	BR 7 (bus request level)	
		BG-1	BR 6	
		LC-1	Internal line clock	
		BG-1	BR 5	
		BG-1	BR 4	
		URTR	UART, Receive	
		URTX	UART Transmit	

Table 9-2 (Cont)
Microprogram Branches (BUT)

BUT	Source	Destination	Comment
SRV (Cont)		H-1	Console STOP
		F-1	None of the above
		W-1	When executing WAIT instruction, LOOP ON W-1 instead of going to F-1.
SW (switch)	H-2	CS-1	Start
		CCS-1	Continue
		CE1-1	Examine 1st.
		CE2-1	Examine
		CD1-1	Deposit 1st.
		CD2-1	Deposit
		CL-1	Load
		H-2	None
		CE1-1	Loop until examine is released.
INT (interrupt)	BG-1	INT-1	Interrupt service
JSRMP	D1-1, D2-3, D3-5, D6-5	J1-1	JMP instruction mode of operation to change PC.
		D6-5	J2-1
INITIALIZE	RST-1		Initialize computer RESET instruction.
UNY (unary)	D0-2	ERT-1	JMP or JSR Mode 0 - illegal instruction
		SB1-1	SWAB
		U1-1	Other unary
	D1-3	SB2-1	SWAB
		U2-1	Other unary
	DB0-1	U3-1	Unary other than JMP, JSR, or SWAB

Table 9-2 (Cont)
Microprogram Branches (BUT)

BUT	Source	Destination	Comment
UNY (Cont)	DE-1	U5-1	Unary other than JMP, JSR, or SWAB
	DO-9	U4-1	Unary other than JMP, JSR, or SWAB
NON (none)			No branch test

9.5 MICROPROGRAM FLOW

The microprogram flow chart is shown in full detail in engineering drawing K-MP-KD11-B-1. Figure 9-2 is a simplified flow that provides an overview and aids in using the detailed flow. No attempt is made in this manual to trace through each path of the microcode. An explanation of the detailed flow notation is provided along with examples to illustrate instruction interpretation, interrupts and traps, and console functions.

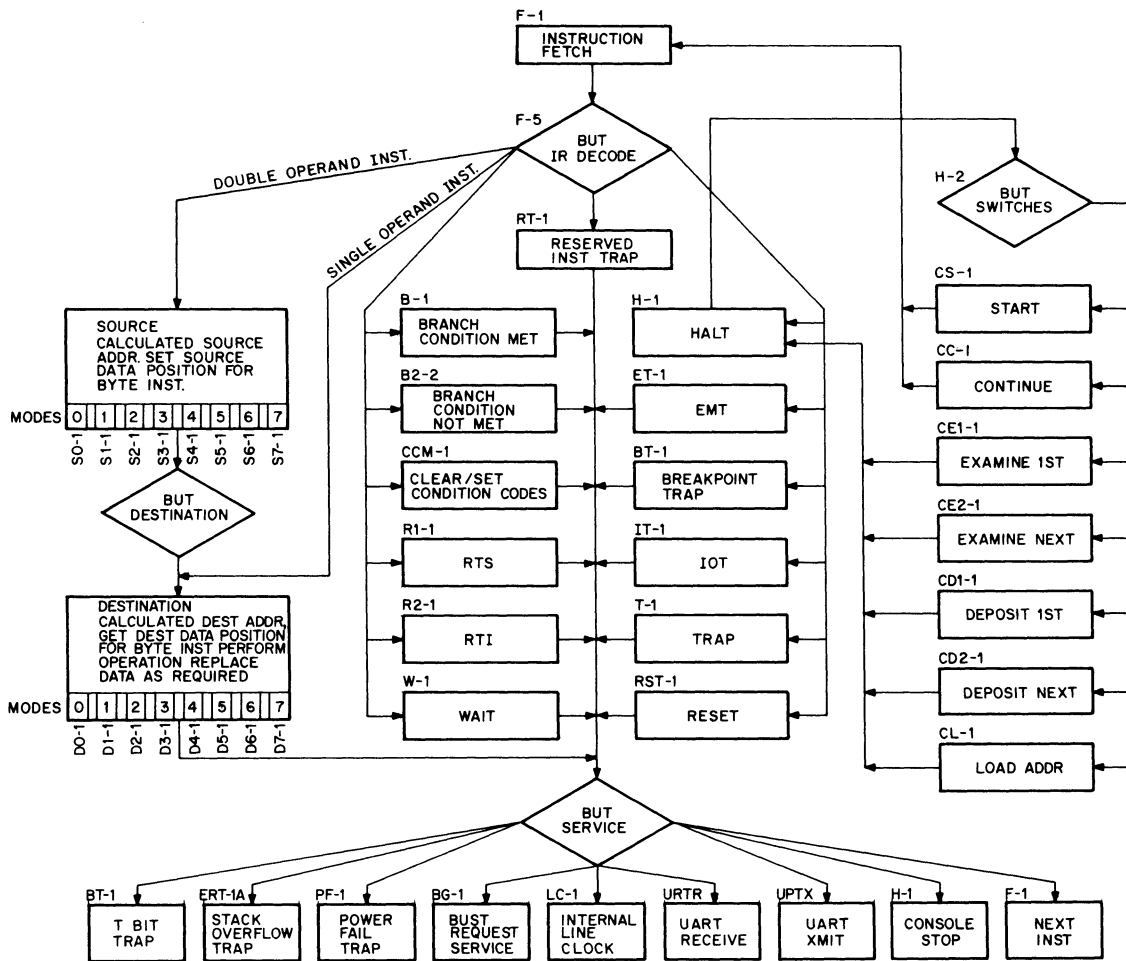

Figure 9-2 KD11-B Simplified Flow Diagram

9.5.1 Flow Chart Notation

Figure 9-3 illustrates an excerpt from the microprogram flow section of the prints. Notice that the listing is grouped into microroutines (source mode 0 through mode 3); these microroutines start with an identifying comment, the first character of which (disregarding the LOC and NXT columns) is an asterisk. Other comment lines begin with a slash.

LOC	NXT	* SOURCE MODE 0 (REGISTER), GET SOURCE DATA
		/ GET TO S0-1 FROM F-5 VIA BUT IR DECODE IR 11:9 = 0
201	007	S0-1 B R[S]; BUT BYTE
		/ IF BYTE INST GOTO SBE-1 (MUST BE EVEN BYTE)
007	001	S0-2 R[10] B; BUT DESTINATION
		/ IF IR 5:3 = 0 GOTO D0-1
		/ = 1 D1-1
		/ = 2 D2-1
		/ = 3 D3-1
		/ = 4 D4-1
		/ = 5 D5-1
		/ = 6 D6-1
		/ = 7 D7-1
LOC	NXT	* SOURCE MODE 1 (REG. DEFERRED) GET SOURCE DATA
		/ GET TO S1-1 FROM F-5 VIA BUT IR DECODE IR 11:9
203	244	S1-1 BA R[S]; DATI; CKOFF; ALBYT
		/ GET TO S1-2 FROM S2-3 VIA GOTO
		/ " S3-5 "
		/ " S6-5 "
244	007	S1-2 B UNIBUS DATA; BUT BYTE; GOTO S0-2
		/ IF ODD BYTE GOTO SBO-1
		/ IF EVEN BYTE GOTO SBE-1
		/ IF NOT BYTE FALL THROUGH TO S0-2
LOC	NXT	* SOURCE MODE 2 (AUTO-INC.) GET SOURCE DATA
		/ GET TO S2-1 FROM F-5 VIA BUT IR DECODE IR 11:9 = 2
205	301	S2-1 BA R[S]; DATI; ALBYT
301	014	S2-2 B R[S]+1+BYTE. BAR
		/ GET TO S2-3 FROM S4-1 VIA GOTO
214	244	S2-3 R[S] 8; CKOFF; GOTO S1-2
LOC	NXT	* SOURCE MODE 3 (AUTO-INC DEFERRED) GET SOURCE DATA
		/ GET TO S3-1 FROM F-5 VIA BUT IR DECODE IR 11:9 = 3
207	016	S3-1 BA R[S]; DATI (MUST BE AN EVEN ADDRESS HERE)
216	017	S3-2 B R[S]+2

Figure 9-3 Excerpt from Microprogram Flow (K-NL-KD11-B-1)

All microsteps have mnemonic names such as S0-1 (source mode 0, step 1), S2-2 (source mode 2, step 2), etc. A microroutine will often weave back and reuse part of another. For example, the source mode 1 routine weaves back into the source mode 0 routine by the GOTO S0-2 in S1-2 (Figure 9-3).

To the left of every microstep is the location of that step in the CS (in octal) and the contents of the NXT field. Observe the microprogram counter (MPC) while single stepping through the microprogram. The LOC and NXT columns provide useful information relating to the path taken by the microprogram.

The flow is well commented and should be self-explanatory. Table 9-3 is a useful glossary of flow notation.

Table 9-3
Flow Notation Glossary

Designation	Definition
BA	Bus Address Register
←	Assignment operator
;	Separator
DATI	Initiate DATI operation on Unibus.
+	Plus, the arithmetic operator
PC	Program Counter = R 7
CKOFF	Set the Clock Off bit of the control store.
B	B-leg register
IR	Instruction Register
B Sex	B-leg register sign extended (bit 7 repeated in bits 8 through 15)
R [S]	Scratch Pad Register specified by the source portion of the current instruction [IR (8:6)].
R [D]	Scratch Pad Register specified by the destination portion of the current instruction [IR (2:0)].
R [n]	Scratch Pad Register n specified by the control ROM
BUT	Branch on microtest
ALBYT	Allow byte Unibus reference
BYTE.BAR	A signal indicating the absence of a byte in instruction
ENABOVER	Enable the stack overflow detection logic (working BUT)
DATO	Initiate DATO operation on Unibus.
DATIP	Initiate DATIP operation on Unibus.
INIT	Initialize the logic (working BUT).

Table 9-3 (Cont)
Flow Notation Glossary

Designation	Definition
SVS	Set slave sync (working BUT).
IRC	Clock the Instruction Register (working BUT).
K [n]	That location of the constants chip (on the data path A-leg) containing the value n.
R [10] OP B	ALU function determined by the auxiliary ALU control logic as a function of the instruction currently in the Instruction Register.
GOTO X	NXT field is to contain the address of X. Unconditional GOTO.

To illustrate the interpretation of PDP-11 instructions, the execution of a CMP instruction is traced through the microcode. The machine is in the RUN state (i.e., the machine is executing instructions) and the instruction is located in memory location 1000.

Location	Assembler Symbolic	Octal
1000	CMP #15, CHAR	022767
1002		000015
1004		000100
.		
.		
.		
1106	CHAR: WORD 0	

This instruction compares the literal 15 to the contents of CHAR and sets the condition code accordingly. Source mode is immediate (mode 2, register 7 = PC) and destination mode is relative (mode 6, register 7 = PC). Figure 9-4 shows the simplified flow for the CMP example.

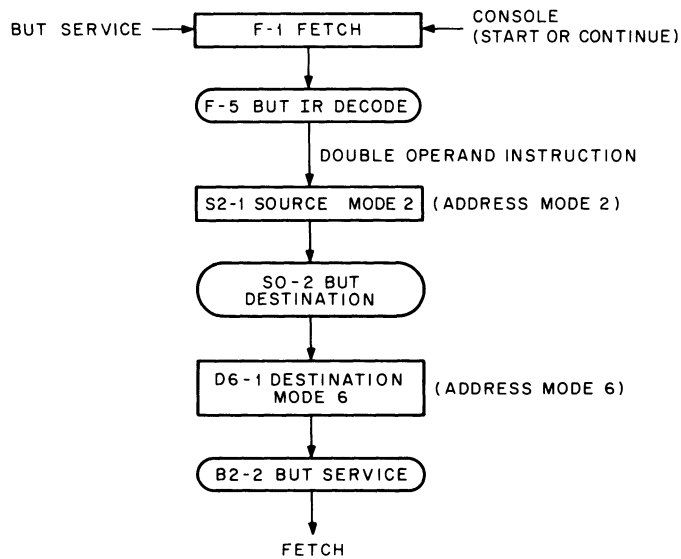

11-1215

Figure 9-4 CMP # 15, CHAR (022767), Simplified Flow Diagram

First the instruction is fetched from memory (microsteps F-1 through F-5). This is the same fetch microroutine used to get each instruction from memory and update the PC.

Location	NXT	Microstep Name	Action	Comment
062	053	F-1	BA ← PC: DATI	/Load the Bus Address Register (BA) with the contents of the PC (R7) and initiate a DATI by the Unibus control (BC).
053	365	F-2	B ← PC+2	/Load the B register with the contents of the PC+2.
365	364	F-3	PC ← B; CKOFF	/Update the PC. CKOFF inhibits execution of the next microstep until the pending Unibus transfer (DATI, initiated in F-1) is complete.
364	061	F-4	B, IR ← UNIBUS DATA	/Load the data from the Unibus (instruction fetched from memory) into the B register and Instruction Register (IR).
061	001	F-5	B ← B SEX; BUT IR DECODE	/Sign extend the low order eight bits of the copy of the instruction in the B register (used in branch instruction interpretation) and branch on microtest (BUT) determined by the IR decode logic. Note that NXT (F-5) = 1 which is the CS location of the RESERVED instruction microroutine. If the IR decode logic does not recognize the instruction, no signals are wire-ORed into the MPC and the RESERVED instruction microroutine (RT-1) is executed by the microprogram. In this example, CMP is recognized (by the IR decode logic) and 204 is wire-ORed with NXT (F-5 = 1) to cause the MPC to be loaded with 205, the location of the microroutine which operates on source mode 2 (S2-1).

Since the instruction is of the double operand group, the next step is to get the source data. Source mode 2 is autoincrement. (Autoincrement implies one level of deferred addressing.) When used with R7 (the PC), it becomes an immediate mode.

Location	NXT	Microstep Name	Action	Comment
205	301	S2-1	BA ← R [S]; DATI; ALBYT	/Load the BA with the contents of the register specified by IR (08:06). The register will contain the location of the source data (1002) in this example. Initiate a Unibus DATI to actually get the data. ALBYT will allow an odd Unibus transfer, if the IR

Location	NXT	Microstep Name	Action	Comment
				contains a byte instruction and the BA contains an odd address. Without the ALBYT, a Unibus transfer that addresses an odd BA results in a bus error (Paragraph 9.3).
301	014	S2-2	$B \leftarrow R [S] + 1 + \text{BYTE} \cdot \text{BAR}$	/For byte instructions, the autoincrement is by one, for non-byte instructions, autoincrement is by two. BYTE BAR indicates that $\text{BLG} (S2-2) = +1$, and this signal is conditioned by the logic, such that it is true (+1) only when the IR does not contain a byte instruction. So actually, R [S] is on the A-leg of the ALU, CARRY IN is enabled, and the +1 constant (enabled only if the IR does not contain a byte instruction) is on the B-leg. The ALU function is $A + B$.
014	244	S2-3	$R [S] \leftarrow B;$	/Update the register which is to be auto-incremented. Inhibit the processor clock until the DATI initiated in S2-1 is complete. From here, the microroutine is woven back into S1-2 [i.e., $\text{NXT} (S2-3) = S1-2$].
244	007	S1-2	$B \leftarrow \text{UNIBUS DATA};$	/Load the source data which has come in from memory into the B register. The microcode at this point joins the microroutine associated with source mode 0 (S0-2). Not a byte instruction, so go to S0-2.
007	001	S0-2	$R [10] \leftarrow B;$ BUT DESTINATION	/Source data is stored in the scratch pad register, R [10], while the destination data is retrieved. BUT DESTINATION will cause a microcode branch dependent on IR (3:5). In this case, the destination mode of 6 will cause 114 to be wire-ORed into the NXT ($S0-2) = 1$, such that the MPC will be loaded with $115 = \text{LOC} (D6-1)$.

The microroutine starting in D6-1 will get the destination data and perform the operation indicated by the OP code of the instruction. Mode 6, when used with the PC, requires that the index contained in the word currently pointed to by the PC be added to the updated PC (address of the index word plus two) to get the location of the source data.

Location	NXT	Microstep Name	Action	Comment
115	075	D6-1	$\text{BA} \leftarrow \text{PC}; \text{DATI}$	/Initiate the Unibus transfer to get the index word from memory.
075	077	D6-2	$B \leftarrow \text{PC} + 2$	/Prepare to update PC to next word.

Location	NXT	Microstep Name	Action	Comment
077	057	D6-3	PC ← B; CKOFF	/Update the PC and inhibit the processor clock until the Unibus DATI initiated in D6-1 is complete.
057	300	D6-4	B ← UNIBUS DATA	/Receive the index word into the B register.
300	200	D6-5	B, BA ← B+R (D); DATI; BUT JSRMP; ALBYT; CKOFF; GOTO D1-2	/The actual location of the destination data is formed by adding the index (in the B register) to the destination register [IR (2:0)], which is the PC in the example. This address is loaded into the BA, and a DATI is issued to retrieve the data from memory. As in S2-1, ALBYT makes odd byte Unibus transfers legal. BUT JSRMP involves a collection of logic which examines the contents of the IR to see if the instruction is a JMP or JSR. If either of these instructions are present, the appropriate bit is wire-ORed with NXT (D6-5) = D1-2 into the MPC, such that the MPC is loaded with J1-1 or J2-1, respectively for JMP or JSR instruction. In the example, neither of these instructions are present and the MPC is loaded with NXT (D6-5) = D1-2. CKOFF inhibits the processor clock until the DATI initiated in this microstep is complete. Note that this is the first time in this example that memory reference has not been overlapped with microprograms.
200	210	D1-2	D ← UNIBUS DATA; BUT BYTE	/Receive the destination data from memory. If the instruction had been a byte instruction (e.g., CMPB), the microprogram would be diverted to D0-1 (for odd byte address) to get the byte operand into the right half of the B register. This is not the case in this example.
210	143	D1-3	R [11] ← B; BUT UNARY	/It is at this point in the microroutine that a branch occurs for unary instructions (e.g., SWAB, CLR, COM, etc.). Unary instructions would have caused the BUT IR DECODE done in F-5 to take the appropriate destination microroutine (there is no source field in a unary instruction). R [11] is used in unary instruction interpretation.
163	334	D1-4	B ← R [10] OP B; BUT NON MOD	/This microstep allows the AUX ALU control ROM (print DPF) to: 1) cause the ALU to perform the appropriate function, and 2) set or clear condition codes in

Location	NXT	Microstep Name	Action	Comment																																				
				accordance with the instruction in the IR and the results of the ALU operation. In the example, it is the setting of condition codes which count. Since CMP is an instruction that does not modify memory, (NONMOD), the microprogram is ready to branch to the microstep in which a BUT SERVICE is done. If the instruction requires a memory modification (e.g., MOV, ADD, INC., etc.), D1-5 and D1-6 are executed before going to BUT SERVICE.																																				
335	040	B2-2B	BUT SERVICE	<p>/At the end of each instruction, various situations that attempt to intervene before the next instruction are tested. Their priorities are arbitrated in the F101 ROM shown on print CONE. These conditions and their relative priorities are as follows:</p> <table border="0"> <tr> <td>High priority</td> <td>1.</td> <td>T-bit trap</td> </tr> <tr> <td></td> <td>2.</td> <td>Stack overflow</td> </tr> <tr> <td></td> <td>3.</td> <td>Power fail</td> </tr> <tr> <td></td> <td>4.</td> <td>Bus request level 7</td> </tr> <tr> <td></td> <td>5.</td> <td>Bus request level 6</td> </tr> <tr> <td></td> <td>6.</td> <td>Internal line clock</td> </tr> <tr> <td></td> <td>7.</td> <td>Bus request level 5</td> </tr> <tr> <td></td> <td>8.</td> <td>Bus request level 4</td> </tr> <tr> <td></td> <td>9.</td> <td>UART receive</td> </tr> <tr> <td></td> <td>10.</td> <td>UART transmit</td> </tr> <tr> <td></td> <td>11.</td> <td>Console stop</td> </tr> <tr> <td>Low priority</td> <td>12.</td> <td>Next instruction</td> </tr> </table> <p>If no condition with a higher priority exists, the microprogram proceeds to F-1 and commences with the fetch of the next instruction.</p>	High priority	1.	T-bit trap		2.	Stack overflow		3.	Power fail		4.	Bus request level 7		5.	Bus request level 6		6.	Internal line clock		7.	Bus request level 5		8.	Bus request level 4		9.	UART receive		10.	UART transmit		11.	Console stop	Low priority	12.	Next instruction
High priority	1.	T-bit trap																																						
	2.	Stack overflow																																						
	3.	Power fail																																						
	4.	Bus request level 7																																						
	5.	Bus request level 6																																						
	6.	Internal line clock																																						
	7.	Bus request level 5																																						
	8.	Bus request level 4																																						
	9.	UART receive																																						
	10.	UART transmit																																						
	11.	Console stop																																						
Low priority	12.	Next instruction																																						

This completes the example of the microprogram interpretation of CMP #5, CHAR. It may be useful to trace this or some other instruction through the detailed flow (K-WL-KD11-B-1).

9.5.2 Interrupts and Traps

Interrupts and traps are also accomplished by the microprogram. Interrupts are sent from Unibus devices; bus requests (BR) are received by the BC. At the end of each instruction (not microstep), if a BR is present, and if it has the highest priority (see microstep B2-2 in previous example), the microprogram goes to BG-1. In BG-1, a BUT INTERRUPT is done to distinguish BRs that are associated with interrupts from those that are not. If an interrupt is required, the microcode is diverted to INT-1 where the interrupt vector location is loaded into R (12) from the Unibus data lines. At this point, the microprogram joins the ET-2 microroutine, which stacks the PSW and PC and retrieves a new PSW and PC from the interrupt vector words. At the end of microroutine ET-13, another BUT SERVICE is done to determine if anything (e.g., another higher priority interrupt or the occurrence of stack overflow) is asserted. If none are, the microprogram proceeds to F-1 where it commences to fetch the next instruction.

Power fail trap, stack overflow trap, and T-bit traps are also recognized during BUT SERVICE. Each of these routines has a microroutine associated with it that loads the B register with the appropriate trap vector location (from the constants ROM, E025 on print DPB). In each case, the microprogram joins the ET-2 microroutine which stacks the PSW and PC and loads the new PSW and PC, just as with external interrupts. The main difference is that the vector location comes from the constants ROM rather than from the UNIBUS DATA.

Bus error traps are treated differently since they may prevent an instruction from being completed. When a bus error is detected, the NXT field of the CS (E092 and E103 on print CONG) is disabled, and the microprogram is forced to ERT-1. This microroutine picks up the respective trap vector location from the constants ROM, and from that point on, operates like all other traps. The difference is the method in which the microprogram gets to ERT-1.

9.5.3 Console Functions

When the processor is in the HALT state, the microprogram is looping on microstep H-2 doing BUT SWITCH. As a console switch is activated, the microprogram branches to an associated microroutine. Additional logic intervenes to distinguish the first of a sequence of examines or deposits. This is illustrated in the following examples.

Assume that the console operator wants to examine locations 1000 and 1002. The processor is in the HALT state, with the microprogram looping on microstep H-2. First the operator must set the switches to 1000 and depress LOAD ADRS. The BUT SWITCH then causes the microprogram to branch to CL-1.

Location	NXT	Microstep Name	Action	Comment
302	300	H-2	BUT SWITCH	/Loop on H-2 waiting for switch action. When LOAD ADRS is depressed, branch to CL-1.
311	375	CL-1	BA ← K [207]. BAR *; DATI; CKOFF	/The SR is logically on the Unibus at location 177570. This constant is obtained from the 8-bit wide constants ROM (F25 on DPB print) by taking 207 and forming the complement through the ALU on the way to the BA. A request for the contents of the SR is initiated (DATI) and the processor clock is inhibited until the data is available (CKOFF).
375	367	CL-2	B ← UNIBUS DATA	/Since the SR is physically on the A-leg of the data path (DP) (prints DPA, DPB, DPC, and DPD), it cannot be written directly into register 17 of the scratch pad; instead, it is first loaded into the B register.
367	302	CL-3	R [17] ← B; GOTO H-2	/Load SR into the Load Address Register, R [17]. Microprogram goes to H-2.
		H-2	BUT SWITCH; GOTO, H-2	/Loop here looking for switch activity. The microprogram loops on CL-1, CL-2, CL-3, and H-2 as long as LOAD ADR is depressed.

*(207). BAR = 1's complement of 207

Now the operator has loaded 1000 from the SR into the Load Address Register R [17]. The lights are attached to the B register and will display the loaded address.

To examine location 1000, the operator depresses EXAM. As long as the EXAM switch is depressed, the location to be examined is displayed in the lights. When it is released, the contents of that location are displayed.

Location	NXT	Microstep Name	Action	Comment
317	307	CE1-1	BA, B ← R [17]; BUT SWITCH	/The lights are connected to the B-leg. By loading the B register with the contents of the Load Address Register, R [17], the address of the location is displayed. The BA is also loaded for subsequent retrieving of the data. BUT SWITCH causes the microprogram to loop on CE1-1 until EXAM is released.
307	326	CE1-2	DATI; CKOFF	/When the switch is released, the data is requested from the Unibus, and the processor clock is inhibited until it is available.
326	302	CE1-3	B ← UNIBUS DATA; GOTO H-2	/Display the data by loading it into the B register and return to the H-2 microprogram loop to await the next switch action.

While the microprogram loops in H-2, the B register remains unchanged and the contents of location 1000 are displayed. When EXAM is depressed a second time, the logic associated with F100 (print CONE) causes BUT SWITCH in H-2 to branch the microcode to CE2-1. In this case, the Load Address Register must be incremented before using its contents.

Location	NXT	Microstep Name	Action	Comment
302	300	H-2	BUT SWITCH	/Loop waiting for switch action.
315	371	CE2-1	B ← R [17] + 2	/Increment the Load Address Register so that sequential words can be examined.
371	317	CE2-2	R [17] ← B; GOTO CE1-1	/Update R [17]. The rest of this micro-routine merges with CE1-1.
317	307	CE1-1	BA, B ← R [17]; BUT SWITCH	
307	326	CE1-2	DATI; CKOFF	
326	302	CE1-3	B ← UNIBUS DATA; GOTO H-2	

This completes the example of console function microroutines. The remaining console functions are quite similar.

9.6 MICROPROGRAM SYMBOLIC LISTING

The microprogram section of the prints (K-MP-KD11-B-1 through 4) contains four useful tools. Paragraph 9.5 describes the microprogram flow. Flow is probably the most useful level to work with the microprogram when tracing through processor action on any specific operation. Flow tells what happens in each microstep and why. To determine how a microstep accomplishes its task, refer to the Microprogram Symbolic Listing (K-MP-KD11-B-2), an excerpt of which is shown in Figure 9-5. In this listing, microsteps are listed alphabetically (e.g., F-1, F-2 . . .). Each of the CS fields described in Table 9-1 is listed along with its symbolic values. For example, in F-2 of the example in Paragraph 9.5.2, flow indicates:

F-2 \leftarrow PC + 2

The symbolic listing is useful for determining how this is to be accomplished in terms of CS fields (e.g., ALU function). Refer to the excerpt in Figure 9-5 and scan the alphabetically-ordered list of names for F-2.

A-leg	(ALG) = SP (scratch pad)
ALU function	(ALU) = A + B
B-leg	(BLG) = +1 (the constant)
B Register	(BRG) = L (load)
Carry In	(CRI) = ON
Scratch Pad Address	(SPA) = R7 (the PC)
Scratch Pad Function	(SPF) = REA (read)
Next MPC	(NXT) = F-3 (go to F-3 next)

$B \leftarrow PC + 2$ is accomplished by gating register 7 (the PC) onto the A-leg of the ALU, gating + 1 onto the B-leg, and causing the ALU to perform an A + B operation ($=R7 + 1$) with Carry In enabled ($=R7 + 1 + \text{carry in}$). The B register is loaded with the results, and the MPC is loaded with the address of F-3, which is the next microstep.

Only eight of a total of eighteen fields are described in the above example. The rest of the fields have values but they are not of immediate interest.

9.7 MICROPROGRAM BINARY LISTING

In addition to the flow and symbolic listing, a binary listing of the CS is included in the microprogram section of the prints (K-MP-KD11-B-3). An excerpt is shown in Figure 9-6. As in the symbolic listing, the binary listing is alphabetically ordered by microstep name. The fields are located across the top of the listing; however, they relate closely to the actual signals (Figure 9-1). A high is represented by a 1 in this listing.

From the previous example, flow indicates F-1 $B \leftarrow PC + 2$. The symbolic listing shows that the ALU function to accomplish this is A + B; the binary listing shows the actual logic level value of CONF ALU S3 L, CONF ALU S2 L, CONF ALU S1 L, CONF ALU S0 L, and CONF ALU MODE H (Figure 9-1 and 9-6). Notice that these five signals are grouped together under the heading ALU. They physically come from chips E104 and E094. The binary listing is spaced to show signals grouped both by field (ALU) and chip (E104 and E094).

If the PC is not being properly incremented during program execution, the flow may be used to determine what is supposed to happen during the fetch microroutine; the symbolic listing is used to determine how it is to be accomplished. If the symbolic listing does not identify the problem, use the binary listing and an oscilloscope probe to locate the incorrect signal and/or malfunctioning chip.

KD11-B MICROPROGRAM SYMBOLIC LISTING

NAME	LOC	ABT	ALG	ALU	AUX	BAR	BLG	BRG	BUT	CON	CKO	CRI	PSW	SAM	SPA	SPF	TNS	NXT
DO-9	132	NO	SP	BL	OFF	H	SEX	L	UNY	NON	OFF	OFF	H	ROM	R11	WRI	NON	A145
ERT-1	010	NO	NUL	AL	OFF	H	BRG	L	CON	4	OFF	OFF	H	ROM	R0	WRI	NON	ET-2
ERT1A	046	NO	NUL	AL	OFF	H	BRG	L	CON	4	OFF	OFF	H	ROM	R0	WRI	NON	ET2-2
ERT1B	153	NO	NUL	AL	OFF	H	BRG	L	CON	4	OFF	OFF	H	ROM	R0	WRI	NON	ET-2
ET-1	011	NO	NUL	AL	OFF	H	BRG	L	CON	30	OFF	OFF	H	ROM	R0	WRI	NON	ET-2
ET-10	254	NO	SP	AL	OFF	L	BRG	H	IRC	NON	ON	OFF	H	ROM	R12	REA	I	ET-11
ET-11	255	NO	SP	AL	OFF	L	BRG	L	NON	NON	OFF	OFF	H	ROM	R7	WRI	NON	ET-12
ET-12	256	NO	SP	A+B	OFF	L	+1	L	NON	NON	ON	ON	H	ROM	R12	REA	I	ET-13
ET-13	257	NO	SP	AL	OFF	H	BRG	L	NON	NON	OFF	OFF	L	ROM	R0	REA	NON	B2-2
ET-2	245	NO	SP	BL	OFF	H	BRG	H	NON	NON	OFF	OFF	H	ROM	R12	WRI	NON	ET-3
ET-3	246	NO	SP	A-B-1	OFF	L	+1	L	END	NON	OFF	OFF	H	ROM	R6	REA	NON	ET-5
ET-5	247	NO	SP	BL	OFF	H	BRG	H	NON	NON	ON	OFF	H	ROM	R6	WRI	O	ET-6
ET-6	226	NO	PSW	AL	OFF	H	BRG	H	NON	NON	OFF	OFF	H	ROM	R0	REA	NON	ET-7
ET-7	251	NO	SP	A-B-1	OFF	L	+1	L	END	NON	OFF	OFF	H	ROM	R6	REA	NON	ET-8
ET-8	252	NO	SP	BL	OFF	H	BRG	H	NON	NON	ON	OFF	H	ROM	R6	WRI	O	ET-9
ET-9	253	NO	SP	AL	OFF	H	BRG	H	NON	NON	OFF	OFF	H	ROM	R7	REA	NON	ET-10
ET2-2	003	NO	SP	BL	OFF	H	BRG	L	NON	NON	OFF	OFF	H	ROM	R12	WRI	NON	ET2-3
ET2-3	004	NO	SP	A-B-1	OFF	L	+1	L	NON	NON	OFF	OFF	H	ROM	R6	REA	NON	ET2-5
ET2-5	036	NO	SP	BL	OFF	H	BRG	H	NON	NON	ON	OFF	H	ROM	R6	WRI	O	ET2-6
ET2-6	037	NO	PSW	AL	OFF	H	BRG	H	NON	NON	OFF	OFF	H	ROM	R0	REA	NON	ET2-7
ET2-7	051	NO	SP	A-B-1	OFF	L	+1	L	NON	NON	OFF	OFF	H	ROM	R6	REA	NON	ET-8
F-1	062	NO	SP	AL	OFF	L	BRG	H	NON	NON	OFF	OFF	H	ROM	R7	REA	I	F-2
F-2	053	NO	SP	A+B	OFF	H	+1	L	NON	NON	OFF	ON	H	ROM	R7	REA	NON	F-3
F-3	365	NO	SP	BL	OFF	H	BRG	H	NON	NON	ON	OFF	H	ROM	R7	WRI	NON	F-4
F-4	364	NO	NUL	AL	OFF	H	BRG	L	IRC	NON	OFF	OFF	H	BAR	R0	REA	NON	F-5
F-5	061	NO	SP	BL	OFF	H	SEX	L	IRD	NON	OFF	OFF	H	ROM	R0	REA	NON	RT-1
H-1	041	NO	SP	AL	OFF	H	BRG	L	NON	NON	OFF	OFF	H	ROM	R7	REA	NON	H-2
H-2	302	NO	SP	AL	OFF	L	BRG	H	SW	NON	OFF	OFF	H	ROM	R17	REA	NON	D6-5
INT-1	325	NO	SP	AL	OFF	H	BRG	H	SVS	NON	OFF	OFF	H	ROM	R12	WRI	NON	ET-3
IT-1	273	NO	NUL	AL	OFF	H	BRG	L	CON	20	OFF	OFF	H	ROM	R0	WRI	NON	ET-2
J1-1	204	NO	SP	AL	OFF	H	BRG	H	NON	NON	OFF	OFF	H	ROM	R0	REA	NON	J1-2
J1-2	260	NO	SP	BL	OFF	H	BRG	H	SRV	NON	OFF	OFF	H	ROM	R7	WRI	NON	BG-1
J2-1	212	NO	SP	AL	OFF	H	BRG	H	NON	NON	OFF	OFF	H	ROM	R0	REA	NON	J2-1A
J2-1A	261	NO	SP	BL	OFF	H	BRG	H	NON	NON	OFF	OFF	H	ROM	R11	WRI	NON	J2-2
J2-2	262	NO	SP	A-B-1	OFF	L	+1	L	NON	NON	OFF	OFF	H	ROM	R6	REA	NON	J2-3
J2-3	214	NO	SP	BL	OFF	H	BRG	H	NON	NON	ON	OFF	H	ROM	R6	WRI	O	J2-4
J2-4	206	NO	SP	AL	OFF	H	BRG	H	ENO	NON	OFF	OFF	H	IRS	R0	REA	NON	J2-5
J2-5	216	NO	SP	AL	OFF	H	BRG	L	NON	NON	OFF	OFF	H	ROM	R7	REA	HON	J2-6
J2-6	263	NO	SP	BL	OFF	H	BRG	H	NON	NON	OFF	OFF	H	IRS	R0	WRI	NON	J2-7
J2-7	264	NO	SP	AL	OFF	H	BRG	L	NON	NON	OFF	OFF	H	ROM	R11	REA	NON	J2-8
J2-8	265	NO	SP	BL	OFF	H	BRG	H	SRV	NON	OFF	OFF	H	ROM	R7	WRI	NON	BG-1
LO-1	042	NO	NUL	AL	OFF	H	BRG	L	CON	100	OFF	OFF	H	ROM	R0	WRI	NON	ET-2
MB-0	154	NO	SP	AL	OFF	H	BRG	H	NON	NON	ON	OFF	H	ROM	R0	REA	NON	MB-1
MB-1	242	NO	SP	ABAR	ON	H	BRG	L	NON	NON	OFF	ON	H	ROM	R10	REA	NON	MB-2

Figure 9-5 Excerpt of (K-WL-KD11-B-2) Microprogram Symbolic Listing

N A M	L O C	N X T	A L U	C F A R R U I E X	P S S D S P P I W 1 3 P	S S S B M P M B O 0 1 T	B B S S A T P P R P F 2	C A T K B N O T S	A B L R G G	B U T	
DO-1B	143	1100	1010	0000	1001	1001	1011	1110	0001	11 01	1111
DO-2	123	1010	1011	0000	1001	1001	1011	1110	1111	11 10	1111
DO-3	124	1010	1010	0000	1001	1001	1011	1110	11 11	11 00	1111
DO-4	125	1010	1001	0000	1001	1001	1011	1110	11 11	11 10	1111
DO-5	126	1010	1000	0000	1001	1001	1011	1110	11 11	11 10	1111
DO-6	127	1010	0111	0000	1001	1001	1011	1110	11 11	11 10	1111
DO-7	132	1010	0110	0000	1001	1001	1011	1110	11 11	11 10	1111
DO-8	131	1010	0101	0000	1001	1001	1011	1110	11 11	11 10	1111
DO-9	132	1001	1010	0101	1001	1011	1111	1000	11 11	11 11	1010
ERT-1	012	0101	1010	0000	1001	1101	1011	1101	11 11	10 11	1101
ERT1A	046	1111	1100	0000	1001	1101	1011	1101	11 11	10 11	1101
ERT1B	153	0101	1010	0000	1001	1101	1011	1101	11 11	10 11	1101
ET-1	011	0101	1010	0000	1001	1101	1011	1110	11 11	10 11	1101
ET-10	254	0101	0010	0000	1001	1111	1011	0110	01 10	11 00	0000
ET-11	255	0101	0001	0000	1001	1101	1111	0101	11 11	11 11	1111
ET-12	256	0101	0000	0110	0101	1111	1010	0110	01 10	11 11	1111
ET-13	257	0011	1010	0000	1001	0001	1011	1110	11 11	11 11	1111
ET-2	245	0101	1001	0101	1001	1111	1011	1100	11 11	11 00	1111
ET-3	247	0110	1001	0101	1001	1101	1011	1101	01 01	11 00	1111
ET-5	247	0110	1001	0101	1001	1101	1011	1101	01 01	11 00	1111
ET-6	226	0101	0110	0000	1001	1001	1011	1110	11 11	00 00	1111
ET-7	251	0101	0101	1001	0001	1101	1010	0111	11 11	11 11	0100
ET-8	252	0101	0100	0101	1001	1101	1011	1101	01 01	11 00	1111
ET-9	253	0101	0011	0000	1001	1101	1111	1111	11 11	11 00	1111
ET2-2	003	1111	1011	0101	1001	1111	1011	1100	11 11	11 11	1111
ET2-3	004	1110	0001	1001	0001	1101	1010	0111	11 11	11 11	1111
ET2-5	036	1110	0000	0101	1001	1101	1011	1101	01 01	11 00	1111
ET2-6	037	1101	0110	0000	1001	1001	1011	1110	11 11	00 00	1111
ET2-7	051	0101	0131	1001	0001	1101	1010	0111	11 11	11 11	1111
F-1	062	1101	0100	0000	1001	1101	1111	0111	11 10	11 00	1111
F-2	053	0000	1010	0110	0101	1101	1110	1111	11 11	11 11	1111
F-3	365	0000	1011	0101	1001	1101	1111	1101	01 11	11 001	1111
F-4	364	1100	1110	0000	1001	1001	0001	1110	11 11	10 11	0000
F-5	061	1111	1110	0101	1001	1001	1011	1010	11 11	11 11	0111
H-1	041	0011	1101	0000	1001	1101	1111	0111	11 11	11 11	1111
H-2	302	0011	1111	0000	1001	1111	1111	0111	11 11	11 00	0110
INT-1	325	0101	1001	0000	1001	1111	1011	1100	11 11	11 00	1000
IT-1	273	0101	1010	0000	1001	1001	1011	1111	11 11	10 11	1101
J1-1	204	0100	1111	0000	1001	1001	1011	1110	11 11	11 00	1111
J1-2	260	1101	1111	0101	1001	1101	1111	1101	11 11	11 00	1100

Figure 9-6 Excerpt of Microprogram Binary Listing (K-W-KD11-B-3)

The following example is used to show the interrelation of the microprogram listings and the logic prints in checking the generation of control signals from the CS ROMs. Specifically, the example deals with the generation of the SPM enabling signals during a microprogram step that requires an SPM read operation. It is a simplified example because only the SPM enabling signals are examined in detail. The address lines, input data, and output data are not examined.

The example chosen is step CCM-2 of the microprogram symbolic listing (print KD11-B-2, sheet 2). The items of interest in this example are as follows.

Name	Location	ALG	CKO	SPF
CCM-2	350	SP	OFF	REA

The step's name is CCM-2 and its location in the CS ROMs is 350₈. Table 9-1 describes the CS fields.

The ALG field is the A-leg control and determines what is enabled onto the A-inputs of the ALU. In this case, SP indicates the contents of the scratch pad memory.

The CKO field determines whether the processor clock is running or is inhibited until the pending Unibus transfer is complete. The notation OFF means that the CKO field has no effect, so the processor clock is running.

The SPF field determines the scratch pad memory control function. The notation REA means that a read operation is selected.

The binary equivalents of the CS field bits are obtained from the microprogramming binary listing (print KD11-B-3, sheet 2).

Name	Location	SPF	CKO	ALG
CCM-2	350	1 (13)	1 (11)	1 1 (07,06)

The CS field bit is shown below the binary representation. The CS field bits run from 00-39, starting with 00 at the right.

In this example, the four signals generated from CS fields ALG, CKO, and SPF are all logical 1.

Refer to Figure 9-1 to determine the signal associated with these fields and the designation of the CS ROM that generates the signal.

The following information is obtained from Figure 9-1.

Field	Bit	Signal	ROM
ALG	06	CONG ROM ALEG 0 L	E093
ALG	07	CONG ROM ALEG 1 L	E093
CKO	11	CONG CKOFF L	E107
SPF	13	CONG SP WRITE L	E095

As previously stated, the purpose of this example is to verify the generation of the SPM enabling signals during a microprogram step that requires an SPM read operation. The last step in the procedure is to trace the signal flow through the logic prints. As a visual aid, all the logic involved is shown in a simplified logic diagram (Figure 9-7). The one exception is the processor clock logic which is not discussed in detail.

In accordance with the function table for the 7489 SPM, during a read operation the E-input is low and the W-input is high (Figure 8-11). This means that signal DPA SP WRITE L must be high and CONG ENAB SPL L and CONG ENAB SPR L must both be low because a word is being read. Signal DPA SP WRITE L is generated by NAND gate E070 (print DPA) which has two inputs. One input is CONJ PROC CLOCK H which is active because the clock is

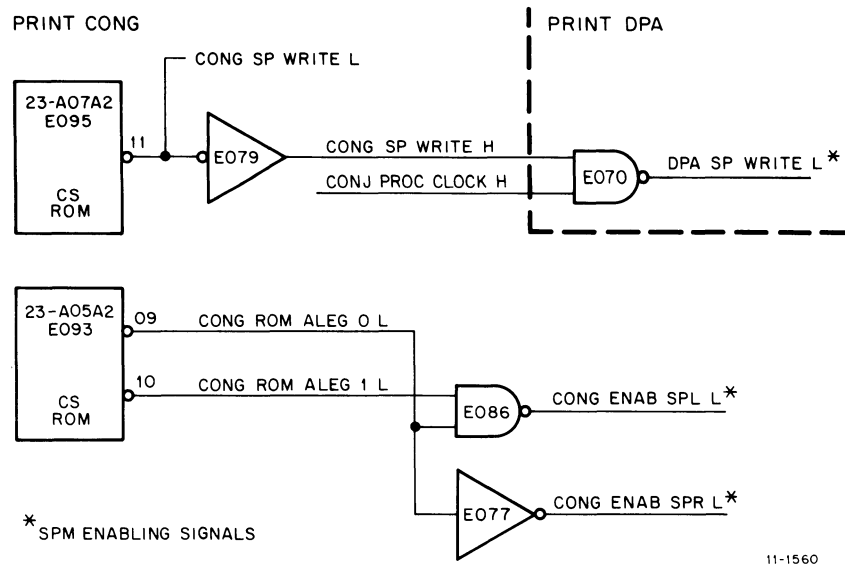

Figure 9-7 Generation of SPM Enabling Signals

running; therefore, it is high when a clock pulse is generated. The other input is CONG SP WRITE H and must be low to generate DPA SP WRITE L = 1. Signal CONG SP WRITE H is the inversion of CONG SP WRITE L which is generated by CS ROM E095. In this example, the microprogramming binary listing states that CONG SP WRITE L = 1. This signal is inverted by E079 to give CONG SP WRITE H = 0 which is the desired input to E070 (print DPA).

Signal CONG ENAB SPR L is the inversion of CONG ROM ALEG 0 L, which is generated by CS ROM E093. In this example, the microprogramming binary listing states that CONG ROM ALEG 0 L = 1. This signal is inverted by E077 to give CONG ENAB SPR L = 0, which is the desired signal.

Signal CONG ROM ALEG 0 L = 1 is also an input to NAND gate E086. The other input is CONG ROM ALEG 1 L = 1 as stated in the microprogramming binary listing. These signals produce CONG ENAB SPL L = 0 at the output of E086, which is the desired signal.

The signals generated by the CS ROMs can be checked by examining the ROM listing (print M7261-0-8). The listing is by ROM part number.

In this example, examine octal address 350 for each ROM referenced to determine the state of the desired signal. The ROM part numbers are listed below.

ROM Part No.	ROM Designation	Output Signal
23-A05A2	E093	{ CONG ROM ALEG 0 L CONG ROM ALEG 1 L
23-A07A2	E095	CONG SP WRITE L
23-A14A2	E107	CONG CKOFF L

9.8 MICROPROGRAM CROSS REFERENCE LISTING

The microstep name (e.g., F-2) is the key that ties the flow, symbolic, and binary listings together. When working with the processor, it is often useful to determine the name of a microstep from a location or vice versa. This information is provided in the cross reference listings (K-MP-KD11-B-4 in the microprogram section of the prints).

CHAPTER 10

KD11-B AND CONSOLE MAINTENANCE

10.1 INTRODUCTION

This chapter describes techniques for isolating and repairing failures in the KD11-B and the console. The basic procedures are aimed at differentiating between failures in the processor and the remainder of the computer. If the processor is at fault, it is necessary to determine which of the two KD-11B modules is defective. The KM11 maintenance panel may be used in conjunction with the KD11-B documentation to isolate failure to specific integrated circuits.

The easiest method of isolating failures and determining if a system will function under worst-case conditions is to use diagnostic programs that have been designed by DEC to test the processor and memory. For most DEC computers, it is possible to assemble a hierarchy of diagnostics that progressively tests more and more of the computer. With large systems, it is possible to test the KD11-B beyond its performance specifications. Diagnostic programs are written and commented in a manner that guides the user in determining computer malfunctions.

This chapter also describes special techniques for troubleshooting the KD11-B. The exact determination of failures and their repair requires careful application of the tools described in this chapter, in addition to a general knowledge of PDP-11 systems. A section on console maintenance provides a console troubleshooting procedure.

10.2 DIAGNOSTICS

The diagnostic programs supplied by DEC provide a rigorous test of the computer that can indicate the need for service even before a failure occurs. Preventive maintenance is especially important on machines that include mechanical components, such as line printers or tape drives.

10.3 TYPES OF FAILURES

Failures can be broken down into three classes: basic, complex, and peripheral. A basic failure of the processor, memory, or program read-in device does not permit diagnostic software to be loaded; thus, fault isolation and repair in a computer with a basic failure requires an elementary approach. A complex failure typically occurs only with programs that generate interaction on the Unibus between several peripherals and the processor. DEC provides a number of system diagnostics, such as the General Test Program (GTP) and the Communications Test Program (CTP), that are useful in isolating complex failures.

Often the failure is caused by a peripheral problem that is unrelated to the processor or memory. In this case, the processor itself may be used as a troubleshooting tool. For example, a diagnostic program is available that tests the alignment of a TU10 Magnetic Tape Drive and reports significant parameters via the serial communications line (SCL).

10.4 SUGGESTED EQUIPMENT

Table 10-1 provides a list of test equipment, maintenance devices, and tools used to perform the processor maintenance procedures and adjustments.

**Table 10-1
Test Equipment and Tools**

Equipment		Description
Test Equipment:	Oscilloscope	Tektronix Model 453 (or equivalent)
	Volt-ohmmeter	Triplett Model 630 (or equivalent)
Devices:	Extender Board	Three W984A Double Extender Boards
	Maintenance Module Set	One W130 (two are desirable) One W131 (two are desirable)
	Maintenance Module Overlays	KM1-DEC Part No. 55-09081-9 KM2-DEC Part No. 55-09081-10
	IC Test Clip	
Tools:	Small Flatblade Screwdriver	

10.5 PROCEDURES

It is useful to know the precise condition of the computer at the time of the failure. The user is advised to record the state of the computer, in as much detail as needed, to reproduce the problem when a failure occurs. At least the following information should be noted:

- a. Any peripherals attached to the Unibus not usually present.
- b. The name of the program running when the failure occurred.
- c. The state of the processor indicators (console) when the failure occurred.
- d. If possible, the sequence of events preceding the failure should be noted.

When running a program on the KD11-B for the first time, it should be noted that certain subtle differences exist among the several PDP-11 processors that can cause problems when non-standard programming practices are used. A list of differences between the KD11-B and other PDP-11 processors is contained in Table 6-8.

Once it is established that a hardware failure exists, the following checks are advised before dismantling the computer:

1. Verify that the power supply is attached to a live ac source and is functioning normally.
2. Verify that the Unibus is properly routed.
3. Be certain that grant continuity cards are properly placed whenever missing peripherals would break the BUS GRANT lines.
4. Be certain that no Unibus address conflicts exist.

Programs can be executed from the scratch pad memory (SP) locations, and if processor problems are suspected, this procedure should be tried to isolate the problem. Communication between the console and processor must be functioning properly in order to use this procedure, and is the first thing to check when a processor problem is suspected. Executing programs from the SP is advantageous for troubleshooting or checking the processor. When executing a program from the SP, the PC (R7) is incremented by one; however, BR instructions always modify the PC by multiples of two. Consequently, a BR instruction must be carefully used in a program to prevent the PC from being modified to an incorrect address. An example of a simple program that loops on two SP register locations is as follows:

Address	Instruction	Octal
1177700 (R0)	NOP	000240
177701 (R1)	BR.-1*	000777

To load the above program from the console, perform the following steps:

1. Enter 177700 in the Switch Register and depress LOAD ADRS (this is the address of register 0).
2. Enter 000240 in the Switch REGISTER and lift DEP. (This places a NOP instruction in R0.)
3. Enter 000777 in the Switch Register and lift DEP.
4. Enter 177700 in the Switch Register and depress LOAD ADRS (this specifies the starting address).
5. Lift ENABLE/HALT to the ENABLE position.
6. Depress START. The RUN light should come on. The program is now being executed.
7. If ENABLE/HALT is pressed, the ADDRESS/DATA display should contain either 177700 or 177701.

When executing programs from the SP (registers), do not use the registers used by the processor (R6, R7, R10, R11, R12, and R17).

10.6 ADJUSTMENTS

Adjustments to the processor are as follows:

1. The processor clock should have a 310-ns period. Adjust, if necessary, performing the following procedures:
 - a. Extend the M7261 module.
 - b. With an oscilloscope, observe the processor clock at E045 pin 6.
 - c. Adjust the potentiometer on the M7261 until the processor clock period is 310 ns.
 - d. Remove oscilloscope probe and reinsert the M7261 module.

* 777_8 is normally a BR self-instruction. However, when executed from the SP, it is a BR. -1, because the SP registers are located on BYTE ADDRESSES.

2. The SCL clock frequency should be 16 times the desired baud rate. Adjust, if necessary, using the following procedure:
 - a. Extend the M7260 module.
 - b. With an oscilloscope, observe the SCL clock at E084 pin 6.
 - c. Adjust potentiometer R74 for 16 times the desired baud rate, according to Table 10-2.
 - d. Remove oscilloscope probe and reinsert the M7260 module.

Table 10-2
Baud Rate Adjustment

Baud Rate	Period (μ s)	Frequency (Hz)
110	568	1760
150	416	2400
300	208	4800

An alternate method for adjusting the SCL clock that does not require extending the module, is to run any program, such as T-17, that causes a continuous stream of characters to be printed on the console. The potentiometer on the M7260 should then be adjusted to the center of the range for which satisfactory characters are printed.

10.7 KD11-B PRINT FUNCTION TABLE

The principles of operation of the KD11-B logic are described in Chapter 8. The microprogram is described in Chapter 7. The KD11-B print set is described in Chapter 7. The KD11-B print set is described in Chapter 5. Table 10-3 lists each engineering drawing for the KD11-B processor and describes the functions of the items shown on that drawing.

Table 10-3
Engineering Drawing Print List and Functions

Print Designation	Print Title	Function of Logic on Print
D-CS-M7260-0-01 DPA	Data Path (3:0)	This print contains the least significant four bits of the DP components, including the ALU, the scratch pad, the B register, the AMUX, Unibus data drivers and receivers, and additional A-leg gating for the PSW and console switches. Prints DPB, DPC, and DPD contain the three other 4-bit parts of the data path.
DPB	Data Path (7:4)	In addition to the items mentioned above, DPB contains the constants generator.

Table 10-3 (Cont)
Engineering Drawing Print List and Functions

Print Designation	Print Title	Function of Logic on Print
D-CS-M7260-0-01 (Cont)		
DPC	Data Path (11:8)	Same as DPA
DPD	Data Path (15:12)	Same as DPA
DPE	PSW	DPE contains the 8-bit PSW and the multiplexers required to load it. Rotate multiplexers are also shown on DPE. The console (MUX shown in the lower right-hand corner of DPE) converts the data presented on the B-leg into a serial bit stream for the console display.
DPF	AUX ALU CONTROL	In addition to the auxiliary ALU control, the Instruction Register (IR) and the C- and V-bit encoder are shown on DPF.
DPG	IR DECODE	The major elements of the IR decoder are shown on DPG.
DPH and DPH1	SCL CONTROL	The UART and other elements of the SCL control are shown on DPH and DPH1.
CONA	INT ADDR	The Bus Address Register (BR) is shown on the left side of CONA. On the right half of the print, the logic required to detect reference to internal registers is diagrammed.
CONB	STACK FLOW AND SPAM	The left half of CONB contains the Scratch Pad Address Multiplexer (SPAM) while the right side contains the stack overflow and RUN flip-flops.
CONC	UNIBUS CONTROL (BC)	Data requests flip-flops are shown towards the left edge of CONC. The lower right-hand quarter of the print contains bus error and CKOFF flip-flops. The 9602 that detects non-existent memory is shown in the lower left-hand corner of CONC.
D-CS-M7261-0-01		
CONC1	PRIORITY ARBITRATION	The priority arbitration logic for bus requests is shown along the bottom edge of CONC1. Towards the left and top of CONC1 are three 4-bit latches used to hold signals received from the Unibus. The 9602 shown on the upper right of CONC1 is used to clear the bus if SACK is not received 22 μ s after NPG or BG.
COND	DRIVE AND RECEIVERS	COND contains all of the Unibus drivers and receivers except those used for the data lines and two drivers used for the line clock circuit.

Table 10-3 (Cont)
Engineering Drawing Print List and Functions

Print Designation	Print Title	Function of Logic on Print
D-CS-M7261-0-01 (Cont)		
CONE	MICRO BRANCH LOGIC	A 4-to-16 line decoder associated with the BUT field of the microprogram is located in the upper left of CONE. The function, switch buffers, and decoders are shown in the upper middle and upper right. Two flip-flops associated with the console EXAM and DEP keys are shown in the lower left and lower center in the trap arbitration logic.
CONF	MPC	Sixteen bits of the CS are shown on the left side of CONF. The MPC is along the right edge of the print.
CONG	CONTROL STORE (CS)	The remaining 23 bits of the CS are shown on CONG.
CONH	POWER FAIL	Initialize and power fail circuitry is shown on CONH. The 9602 contained in the lower left-hand corner of CONH generates bus instructions during the RESET instruction.
CONI	LINE CLOCK	The circuit equivalent to the KW11-L is contained on CONI.
CONJ	PROCESSOR CLOCK	The circuit consisting of E19, R2, R10, and C115 comprises the oscillator that generates the processor clock. The input to E02713 is used by the KM11 to generate clock signals from an external source.

10.8 EXTERNAL CLOCK INPUTS

External clock inputs and corresponding internal clock disables are provided for the serial communications line (SCL) clock and the processor clock. The external input for the SCL clock permits the reception and transmission of serial asynchronous data at rates up to 10,000 baud. High baud rate signals should be input on pin FM1 of the M7260, rather than the low frequency input on pin FN1. The SCL clock, its external disable, and external clock input are shown on print DPH.

The external clock input for the processor clock permits the synchronization of two processors or the use of a manual clock. The manual clock input and the internal processor clock disable are shown on print CONJ.

10.9 KM11 MAINTENANCE PANEL

The discussion to this point has not considered the backplane or configuration. Every KD11-B contains the necessary logic to permit single step operation; however, the use of these facilities depends on the specific configuration. Two module slots are provided in the computer for the maintenance panel. Figure 10-1 contains a diagram of the KM11 overlays for slots KM-1 and KM-2 in the computer backplane (Figures 1-2 and 1-3). Table 10-4 provides description of the overlay designations. Note the following:

- a. The KM-1 switches have the same function in slots KM-1 and KM-2.
- b. When the manual clock is enabled, bus error timeouts are disabled. Nonexistent memory trap cannot occur in manual mode.

- c. Each actuation of the manual clock with line EV1 of the M7261 grounded produces bus control (BC) clock. It normally requires two BC clock pulses to advance the microprogram counter (MPC) to the next address.
- d. The MPC is duplicated on both KM11 slots. This permits the user who has only one KM11 to plug the unit into either KM-1 or KM-2.
- e. The MPC displayed on the KM11 is the address of the next microstep to be selected and not the present one.
- f. Some lights on the maintenance panel indicate the assertion of a signal when illuminated and others indicate nonassertion when illuminated. This fact is indicated on the KM11 overlay drawing by the letter B for bright or D for dim appearing under each indicator light.

B = bright for assertion (logic 1)
 D = dim for assertion (logic 1)

- g. The wiring for KM-1 appears in slot A2, and the wiring for KM-2 appears in slot B2 for a Configuration 2 backplane. KM-1 and KM-2 are wired to slots A1 and B1, respectively, for a Configuration 1 backplane.

KM-1 is the more useful configuration and should be used to begin any repair attempts requiring the use of the maintenance panel. The console indicators display the B-leg input to the ALU, and the KM-1 configuration maintenance panel displays the output of the AMUX. If the ALU and AMUX are functioning, it is possible to deduce the contents of the A-leg by observing the console and the maintenance panel.

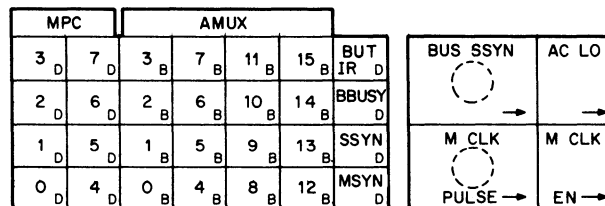

(a) KM-1 OVERLAY

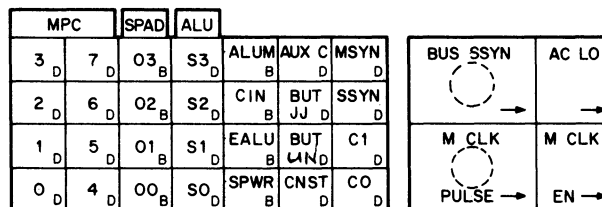

(b) KM-2 OVERLAY

NOTE:
 D = Dim when asserted.
 B = Bright when asserted.

11-1271

Figure 10-1 KM11 Maintenance Module, KD11-B Overlays

**Table 10-4
KM-1 and KM-2 Overlay Designations**

Display	Definition
KM-1 OVERLAY	
MPC (7:0)	The address of the next microinstruction to be executed. <i>Input to MICROINSTR. CONTROL</i>
AMUX (15:0)	The 16-bit <u>output</u> of the AMUX.
BUT IR	BUT IR DECODE signal. When asserted, the microprogram is at F-5 and does a branch on the contents of the IR.
BBUSY	BUS BUSY. When asserted, BBSY indicates that a device has control of the Unibus.
SSYN <i>UNIBUS CONTROL</i>	BUS SLAVE SYNC. When asserted, SSYN indicates that the Unibus slave device has responded to the master.
MSYN	BUS MASTER SYNC. When asserted, MSYN indicates that the master device on the Unibus is informing the selected slave that address and control information are present.
BUS SSYN	When actuated in the direction of the arrow (ON), SWITCH BUS SSYN asserts BUS SLAVE SYN as long as the switch is ON.
AC LO	When actuated in the direction of the arrow (ON), AC LO asserts BUS AC LO as long as the switch is ON.
M CLK PULSE (Manual Clock Pulse)	Each actuation in the direction of the arrow (ON), the processor generates one bus control clock, provided that CLK EN switch has been actuated. Two actuations will generate a processor clock.
M CLK EN	When actuated in the direction of the arrow (ON), it disables the processor clock logic and allows the M CLK PULSE switch to generate processor clocks.
KM-2 OVERLAY	
MPC 7 through 0	The address of the next microinstruction to be executed.
SPAD (Scratch Pad Address)	The address of the register (location) in the scratch pad memory. <i>4 BIT output of SPAM</i>
ALU S3 through S0 ALU M <i>ALU M</i>	These five signals together indicate the function that the ALU is performing. <i>output of ALU function control</i>
CIN	Carry in signal to bit 0 of the ALU.
E ALU	Enable ALU is the signal that switches the AMUX from inputting the Unibus data lines to inputting at the output of the ALU. <i>ALU DATA OR UNIBUS DATA THRU AMUX</i>

Table 10-4 (Cont)
KM-1 and KM-2 Overlay Designations

Display	Definition															
SP WR SFF	Scratch Pad Write indicates that the SPM is doing a write function as opposed to a read.															
AUX CNTRL	Auxiliary Control enables the AUX ALU ROMs on print DPF.															
BUT J J	Signifies that a branch test for a JMP or JSR instruction is occurring.															
BUT UN	Signifies that a branch test for a unary instruction is occurring.															
CNST <i>WORKING? BUT COW</i>	Signifies that the constants ROM, F025 on M7260, is enabled.															
MSYN	Same as MSYN on KM-1															
SSYN	Same as SSYN on KM-1															
C1 and C0	BUS C1 and C0 together signify the type of Unibus cycle that is occurring: <table border="1" style="margin-left: auto; margin-right: auto;"> <thead> <tr> <th>C1</th> <th>C0</th> <th></th> </tr> </thead> <tbody> <tr> <td align="center">0</td> <td align="center">0</td> <td>DATI</td> </tr> <tr> <td align="center">0</td> <td align="center">1</td> <td>DATIP</td> </tr> <tr> <td align="center">1</td> <td align="center">0</td> <td>DATO</td> </tr> <tr> <td align="center">1</td> <td align="center">1</td> <td>DATOB</td> </tr> </tbody> </table>	C1	C0		0	0	DATI	0	1	DATIP	1	0	DATO	1	1	DATOB
C1	C0															
0	0	DATI														
0	1	DATIP														
1	0	DATO														
1	1	DATOB														

10.10 USING KM11 MAINTENANCE PANEL

Assume that the maintenance panel is plugged into slot A2 for the KM-1 overlay configuration. The M CLK EN switch must be activated in the direction of the arrow, which disables the processor M CLK PULSE. The following example uses the sequence of microsteps described in Paragraph 9.5.3.

With the HALT switch depressed, hold down the START switch. Toggle the M CLK PULSE switch advance two times, then release the START switch and toggle two more times. The processor should now be in microstep CS-2. The MPC should read 321₈, which is the contents of the NXT field of LOC 100₈ of the CS. Repeated actuation of the M CLK PULSE switch should cause the microprogram to proceed as follows:

Location	NXT (MICRO PC)	Step Name
100	322	CS-1
322	321	CS-2
321	40 + 1*	CS-3
41	302	H-1
302	300 + 2	H-2

*In step CS-3 the NXT field contains 40. However, if the HALT switch is depressed, a 1 is ORed into the NXT field to cause a branch to H-1.

10.11 CONSOLE MAINTENANCE

If any malfunctions are suspected in the console display logic, the console may be put into service mode. This mode of operation induces known data into the serial data line from the computer to verify that the counters, clock, and shift registers of the console logic on the console board are functioning properly. If the data on the console display does not match the known data, then the closed loop can be probed with an oscilloscope to determine the faulty area.

The procedure takes the four Scan Address lines and feeds them one at a time into the serial data output line, the address/data multiplexer is bypassed. Since the clock is free running, each scan address line displays a known data pattern in the console lights. The troubleshooting procedure for the console is as follows:

1. Make certain the computer power is off.
2. Disconnect the console cable connector from the M7260 module and then turn on the computer power.
3. After Step 2 is completed, the data pattern 177777_8 should be displayed on the console lights.
4. At the Berg cable connector that plugs into the M7260 module, use a piece of small gauge wire and jumper pin F (signal DAK, serial output line) to pin B2 (ground). All the console lights should be off. Remove the jumper before proceeding to the next step.
5. At the cable connector, jumper pin F (signal DAK) to pin N (SCAN ADDRESS 01). The pattern displayed on the lights, should be 052525_8 . Remove the jumper before proceeding to the next step.
6. At the cable connector, jumper pin F to pin L (SCAN ADDRESS 02). The pattern displayed on the lights should be 031463_8 . Remove the jumper before proceeding to the next step.
7. At the cable connector, jumper pin F to pin J (SCAN ADDRESS 04). The pattern displayed on the lights should be 007417_8 . Remove jumper before proceeding to the next step.
8. At the cable connector, jumper pin F to pin D (SCAN ADDRESS 08). The pattern displayed on the lights should be 000377_8 . Remove jumper after completing the step.

PART 3

MM11-K AND MM11-L MEMORIES

Part 3 provides both general and detailed descriptions of the MM11-K and MM11-L core memories that are used in the PDP-11/05 and PDP-11/10. Maintenance information is also included. The chapters of Part 3 are:

- Chapter 11 – MM11-K and L General Description
- Chapter 12 – MM11-K and L Detailed Description
- Chapter 13 – Memory Maintenance

CHAPTER 11

MM11-K AND L GENERAL DESCRIPTION

11.1 INTRODUCTION

This chapter provides the user with the theory of operation and logic diagrams necessary to understand and maintain the MM11-K and MM11-L Read/Write Core Memories. The level of discussion assumes that the reader is familiar with basic digital computer theory. Both general and detailed descriptions of the core memories are included.

Although memory control signals and data pass through the Unibus, it is beyond the scope of this discussion to describe the operation of the Unibus. A detailed description of the Unibus is presented in the *PDP-11 Peripherals and Interfacing Handbook*.

A complete set of engineering logic drawings is shipped with each core memory. These drawings are bound in a separate volume entitled *MM11-K and L Core Memories, Engineering Drawings*. The drawings reflect the latest print revisions and correspond to the specific memory shipped to the user.

11.2 GENERAL DESCRIPTION

This paragraph provides a physical description and specifications for the memory. The major functional units of each memory are briefly described, and the basic memory operations are discussed.

11.2.1 Physical Description

The MM11-K provides 4096 (4K) 16-bit words; the MM11-L provides 8192 (8K) 16-bit words. Both configurations require three standard 8-1/2 inch wide modules: two are hex-height and one is quad-height.

The quad-height module contains the memory stack: module H213 for 4K; and module H214 for 8K. One hex-height module (G110) contains the control logic, inhibit drivers, sense amplifiers, and 16-bit data register; the other hex-height module (G231) contains the address selection logic, current generator, and switches and drivers. Pin-to-pin compatibility exists between the C, D, E, and F connectors of both these modules are also compatible with the standard Unibus pin assignments.

It is recommended that the G231 Driver Module be installed between the G110 Control Module and the H213 or H214 Stack Module. Photographs of the component sides of the modules are shown in Figures 11-1, 11-2, and 11-3.

11.2.2 Specifications

The general memory specifications are listed in Table 11-1.

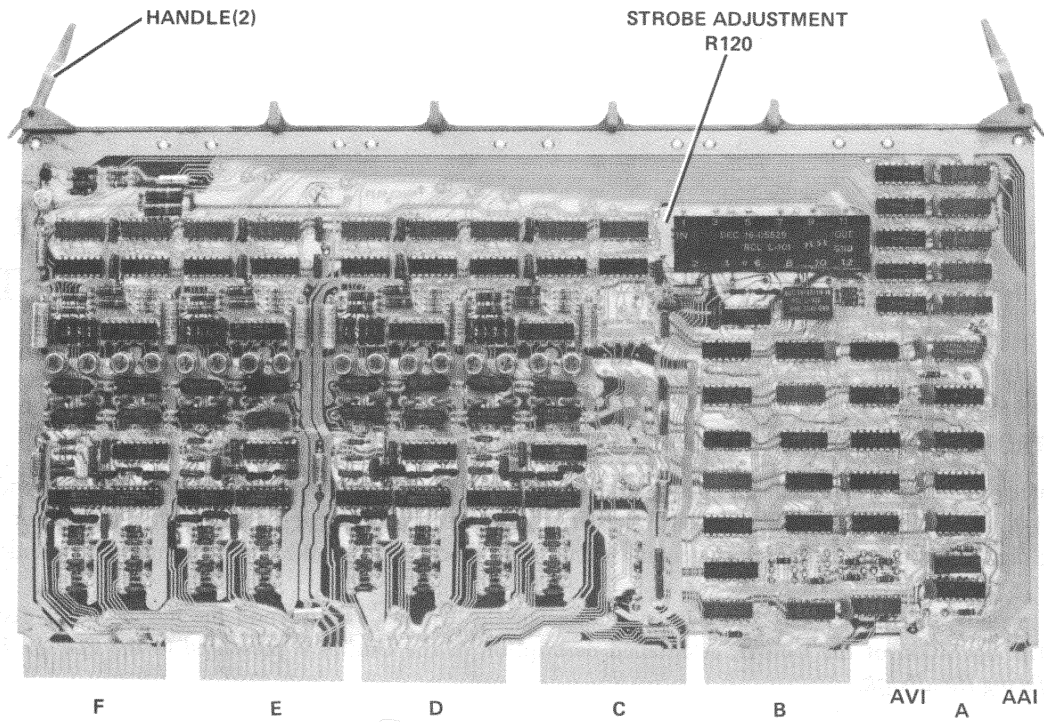

Figure 11-1 Component Side of G110 Control Module

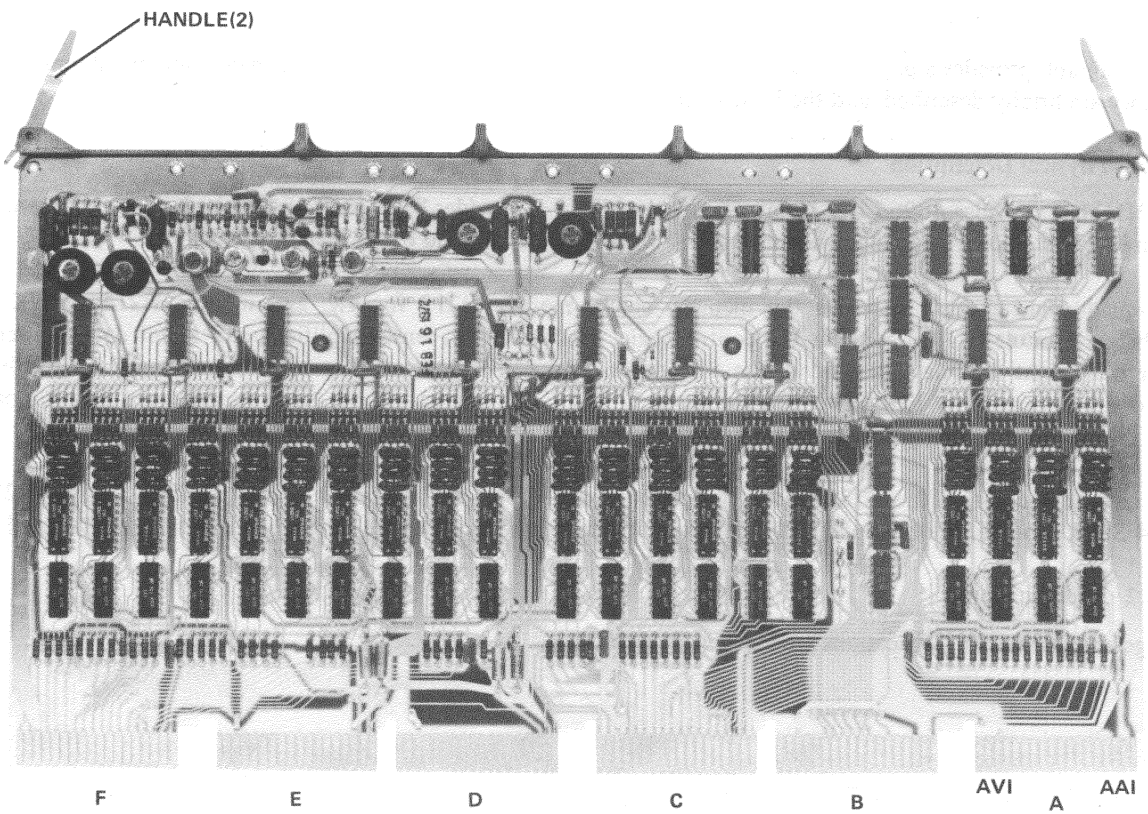

Figure 11-2 Component Side of G231 Driver Module

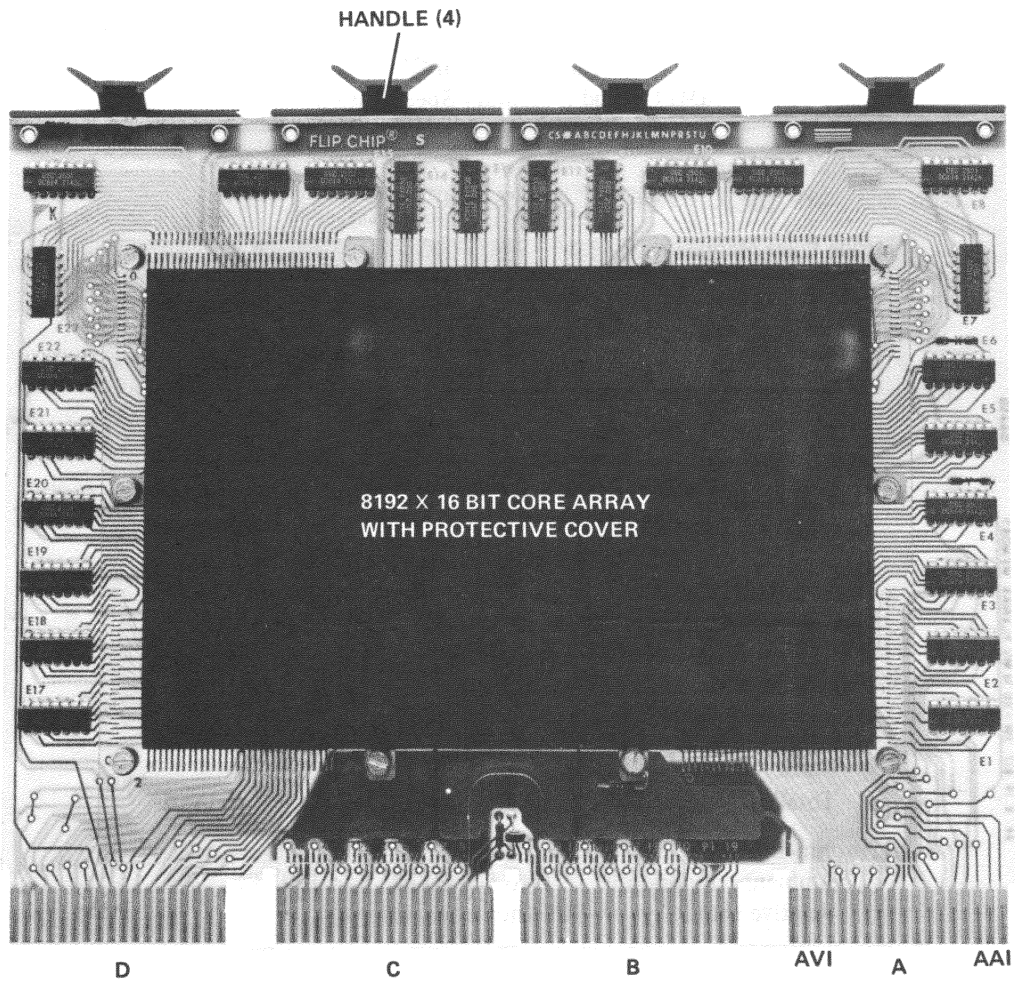

Figure 11-3 Component Side of 8K H214 Stack Module

Table 11-1
MM11-K and L Memory Specifications

Type:		
Magnetic core, read/write, coincident current, random access.		
Organization:		
Planar, 3D, 3-wire		
Capacity:		
4096 (4K) words for MM11-K		
8192 (8K) words for MM11-L		
Access Time and Cycle Time:		
Bus Mode	Cycle Time	Access Time
DATI	900 ns	400 ns
DATIP	450 ns	400 ns
DATO DATOB	900 ns	200 ns
(PAUSE L)		
DATO-DATOB	450 ns	200 ns
(PAUSE H)		

Table 11-1 (Cont)
MM11-K and L Memory Specifications

X-Y Current Margins:
±6% @ 0° C, ±7% @ 25° C, ±6% @ 50° C
Strobe Pulse Margins:
±30 ns @ 0° C, ±40 ns @ 25° C, ±30 ns @ 50° C
Voltage Requirements:
+5V ±5% with less than 0.05V ripple
-15V ±5% with less than 0.05V ripple
Average Current Requirements:
Stand by
+5V: 1.7A
-15V: 0.5A
Memory Active
+5V: 3.4A
-15V: 6.0A
Power Dissipation (worst case):
Control Module (G110): ≅ 60W
Drive Module (G231): ≅ 40W
Stack Module (H213 or H214): ≅ 20W
Total at maximum repetition rate: 120W
Environment:
Ambient temperature: 0° C to 50° C (32° F to 122° F)
Relative Humidity: 0–90% (non-condensing)

11.2.3 Functional Description

The memory is a read/write, random access, coincident current, magnetic core type with a cycle time of 900 ns and an access time of 400 ns. It is organized in a 3D, 3-wire planar configuration. Word length is 16 bits, and the memory is offered in two word capacities: the MM11-K contains 4096 (4K) words, and MM11-L contains 8192 (8K) words. The major functional units of the memory (Figure 11-4) are briefly described in the following paragraphs.

11.2.3.1 G110 Control Module – The G110 Control Module contains the memory control circuits, inhibit drivers, sense amplifiers, data register, threshold circuit, -5V supply, and device selector.

- a. *Memory Control Circuits* – Control circuits are provided to acknowledge the request of the master device, determine which of the four basic operations (DATI, DATIP, DATO or DATOB) is to be performed, and set up the appropriate timing and control logic to perform the desired read or write operation. If a byte operation has been selected, address line A00 L determines the byte to be selected. The actual read or write operation is selected by control lines (C00 and C01). The memory control logic also transfers data to and from the Unibus.
- b. *Inhibit Driver* – Each bit mat contains a single inhibit/sense line that passes through all cores on the mat. To write a 0 into a selected bit, an inhibit current is passed through the inhibit/sense line that cancels the write current in the Y-line. The core does not switch, so it remains in the 0 state. With no inhibit current, the currents in the X- and Y-lines switch the core to the 1 state.

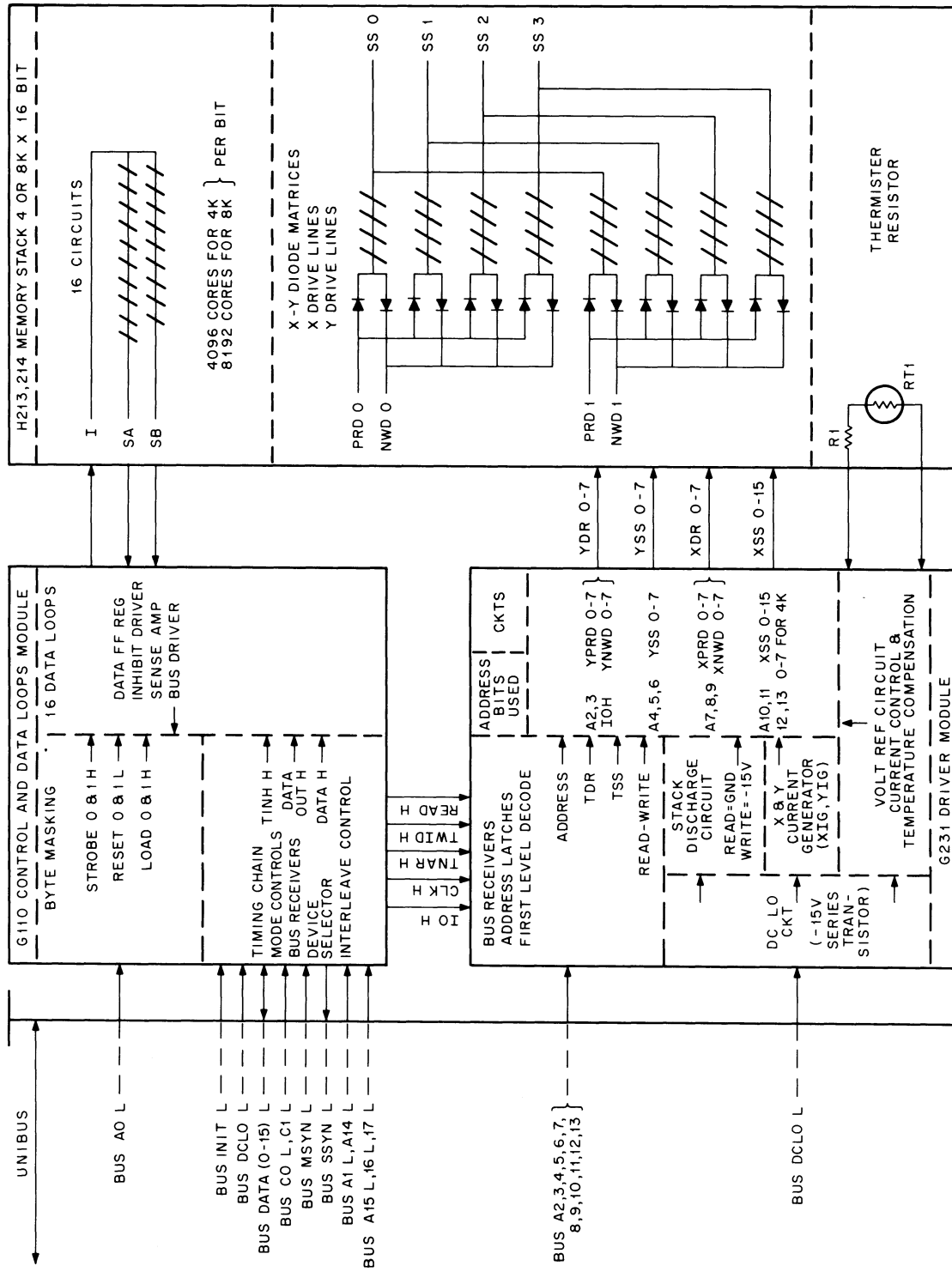

11-1148

Figure 11-4 MM11-K, L Memory Block Diagram

- c. *Sense Amplifiers* – During a read operation, the sense amplifier picks up a voltage induced in the sense/inhibit winding when a core is switched from a 1 to a 0. This signal is detected and amplified by the sense amplifier whose output sets a data register flip-flop to store a 1. In effect, a 1 is read but the core is switched to the 0 state. Cores which were previously set to 0 are not effected.
- d. *Data Register* – The data register is a 16-bit flip-flop register used to store the contents of a word after it is destructively read out of the memory; the same word can then be written back into memory (restored) when in the DATI mode. The register is also used to accept data from the Unibus lines to accommodate the loading of incoming data into the core memory during the DATO or DATOB cycles.
- e. *Device Selector* – The device address is decoded in the device selector to determine if the memory bank has been addressed.
- f. *Threshold Circuit and -5V Supply* – The threshold circuit provides a reference threshold voltage to the sense amplifiers. During a read operation, if the threshold voltage (20 mV) is exceeded, the sense amplifier produces an output. The -5V supply provides a negative voltage for the sense amplifiers.

11.2.3.2 G231 Driver Module – The G231 Driver Module contains the address selection logic, switches and drivers, current generator, stack discharge circuit, and DC LO protection circuit.

- a. *Address Selection Logic* – The core memory receives an 18-bit address from the master device. The address is latched and decoded to determine if the memory is the selected device and to determine the core location specifically addressed. If the operation is a byte operation, bus line A00 L indicates the byte to be used. The X- and Y-portion of the address is decoded through selection switches and a diode matrix to enable passage of read/write current through the selected X- and Y-drive lines of the memory. The coincidence of these currents selects the specific 16-bit core memory location desired.
- b. *Switches and Drivers* – The switches and drivers direct the flow of current through the magnetic cores to ensure the proper polarity for the desired function. This action is necessary because a single read/write line is used, and the current for a write operation is opposite in polarity to the current required for a read operation. There are separate switches and drivers for the read and write circuits in the selection matrix.
- c. *Current Generators* – X- and Y-current generators provides the current necessary to change the state of the magnetic cores. The linear rise time and amplitude of the output-current waveform have been selected to provide optimum switching of the core states and maximum signal-to-noise ratio for a wide range of temperatures.
- d. *Stack Discharge Circuit* – The stack discharge circuit maintains the proper stack charge voltage during operation: approximately 0V during a read operation and approximately -14V during a write operation.
- e. *DC LO Protection Circuit* – If any dc voltage is out of tolerance, DC LO is asserted on the Unibus. It is sensed by the DC LO protection circuit, which inhibits the memory operation by opening the -15V line to the current source. This prevents spurious memory operation.

11.2.3.3 H213 or H214 Stack Module – The stack module contains the ferrite core array and the X-Y diode matrices. For the 4K memory (H213), 16 core mats are used, each wired in a 64 X 64 matrix; 16 core mats, each wired in a 128 X 64 matrix are used for the 8K memory (H214). The stack also contains the resistor/thermistor combination to control the X-Y current generator temperature compensation.

11.2.4 Basic Memory Operations

The core memory has four basic modes of operation. The main function of the memory is simply to read and write data. Additional modes are provided, however, to allow for byte operation and to eliminate the restore cycle when it is not needed, thereby increasing overall system efficiency. The four basic memory operations are:

- a. Read/restore (DATI)
- b. Read pause (DATIP)
- c. Write (DATO)
- d. Write byte (DATOB).

These four modes are discussed briefly in the following paragraphs.

NOTE

In the following discussions, all operations refer to the master (controlling) device. For example, the term “data out” indicates data flowing out of the master and into the memory.

11.2.4.1 Data In (DATI) Cycle – The DATI cycle is a read/restore memory cycle. During this operation, the memory reads the information from the selected core location, transfers it to the Unibus, and then writes the information back into the memory location. This last step is necessary because the core memory is a destructive readout device. During the first part of the cycle, the memory loads the data into a register; at the same time, the memory applies the data to the Unibus. Then, during the second part of the cycle, the memory takes the data from the register and writes it back into the addressed memory location.

11.2.4.2 Data In, Pause (DATIP) Cycle – Normally in reading from memory, the information is destroyed in the particular location accessed, and the data must be restored. However, sometimes it is not actually necessary to restore the information after reading, because the location is to have new data written into it. In this instance, eliminating the restore operation decreases the memory cycle time by approximately 50 percent. The DATIP operation is used for this purpose. The data is read from memory and the restore cycle is inhibited. Because no restore cycle is used, a DATIP must always be followed by a write cycle (either DATO or DATOB) on the same address or data in both addresses will be destroyed. If a DATIP is not followed by a DATO or DATOB, the memory controller will be unable to control the bus, and other devices will be unable to access the bus (this is known as hanging the bus).

11.2.4.3 Data Out (DATO) Cycle – The DATO cycle is a write memory cycle used by the master device to transfer data into core memory. To ensure that proper data is stored, the memory unit must first be cleared by reading the cores (thereby setting them all to 0) before writing in the new data. During a normal DATO, the memory first performs the read operation to clear the cores and then performs a write cycle to transfer data from the bus into the selected core location. If a DATO follows a DATIP (rather than a DATI), the sequence is not the same. The DATIP clears core and generates a pause flag; the DATO skips the read cycle and immediately begins the write cycle. This process reduces DATO cycle time by approximately 50 percent.

11.2.4.4 Data Out, Byte (DATOB) Cycle – The DATOB cycle is similar in function to the DATO cycle, except that during DATOB data is transferred into the core memory from the bus in byte form rather than as a full word. During the read cycle, the non-selected byte is saved by reading it into the data register while the selected byte is transferred into the register from the bus. During the write cycle, only the selected byte portion of the word is loaded into the memory location from the bus. At the same time, the non-selected byte is restored from the data register into the memory location. In effect, the memory is first cleared and then simultaneously performs a restore cycle for the non-selected byte and a write cycle for the selected byte. This mode can follow a DATIP as described above.

CHAPTER 12

MM11-K AND L DETAILED DESCRIPTION

12.1 INTRODUCTION

This chapter provides a detailed description of the MM11-K and L memories. The discussion is related to the 8K memory (MM11-L). The description of the 4K memory (MM11-K) is basically the same; only the differences are discussed.

The detailed description covers the core array, device and word selection, switches and drivers, current generation, stack discharge circuit, DC LO circuit, sense/inhibit circuitry, control and timing logic, and memory operating cycles.

12.2 CORE ARRAY

The ferrite-core array for the 8K memory consists of 16 mats arranged in a planar configuration. Each mat contains 8192 ferrite cores arranged in a 128×64 array. Each mat represents a single bit position of a word. This planar configuration provides a total of 8192 16-bit word locations. The 4K memory core array consists of 16 mats each arranged in a 64×64 planar configuration to provide a total of 4096 16-bit word locations. Each ferrite core can assume a stable magnetic state corresponding to either a binary 1 or a binary 0. Even if power is removed from the core, the core retains its state until changed by appropriate control signals. The outside diameter of each core is 18 mil; the inside diameter is approximately 11 mil. Each core is 4.5 mil thick.

Selection and switching of the cores is provided by three wires traversing each core in a special selection technique. An X-axis read/write winding passes through all cores in each horizontal row for all 16 mats. A Y-axis read/write winding passes through all cores in each vertical row for all 16 mats. Through the use of selection circuits which control the current applied to specific X-Y windings, any one of the 8192 or 4096 word locations can be addressed for writing data into memory or reading data out of memory. A third line passes through each core on a mat to provide the sense/inhibit functions. There is one sense/inhibit line per mat. This single sense/inhibit line, as well as the selection circuits, are discussed in subsequent paragraphs.

12.3 MEMORY OPERATION

Figure 12-1 illustrates a typical portion of the core memory. An X- and Y-winding pass through each core in the mat. The current passing through any one winding is such that no single winding produces a magnetic field strong enough to cause a core to change its magnetic state. Only the reinforcing magnetic field caused by the coincident current of both an X- and Y-winding can cause the core located at the point of intersection to change states. It is this principle that allows the relatively simple winding arrangement to select one and only one memory core out of the total contained on each mat. The current passing through either an X- or Y-winding is referred to as the half-select current.

A half-select current passing through the X3 winding (Figure 12-1) from left to right produces a magnetic field that tends to change all cores in that horizontal row from the 0 to 1 state. The flux produced by the current is, however, insufficient to complete the state transition in any core. Simultaneously passing a half-select current through the Y2 winding from top to bottom produces the same effect on all cores in that particular vertical row. Note, however, that both currents pass through only one core which is located at the intersection of the X3 and Y2 windings. This is

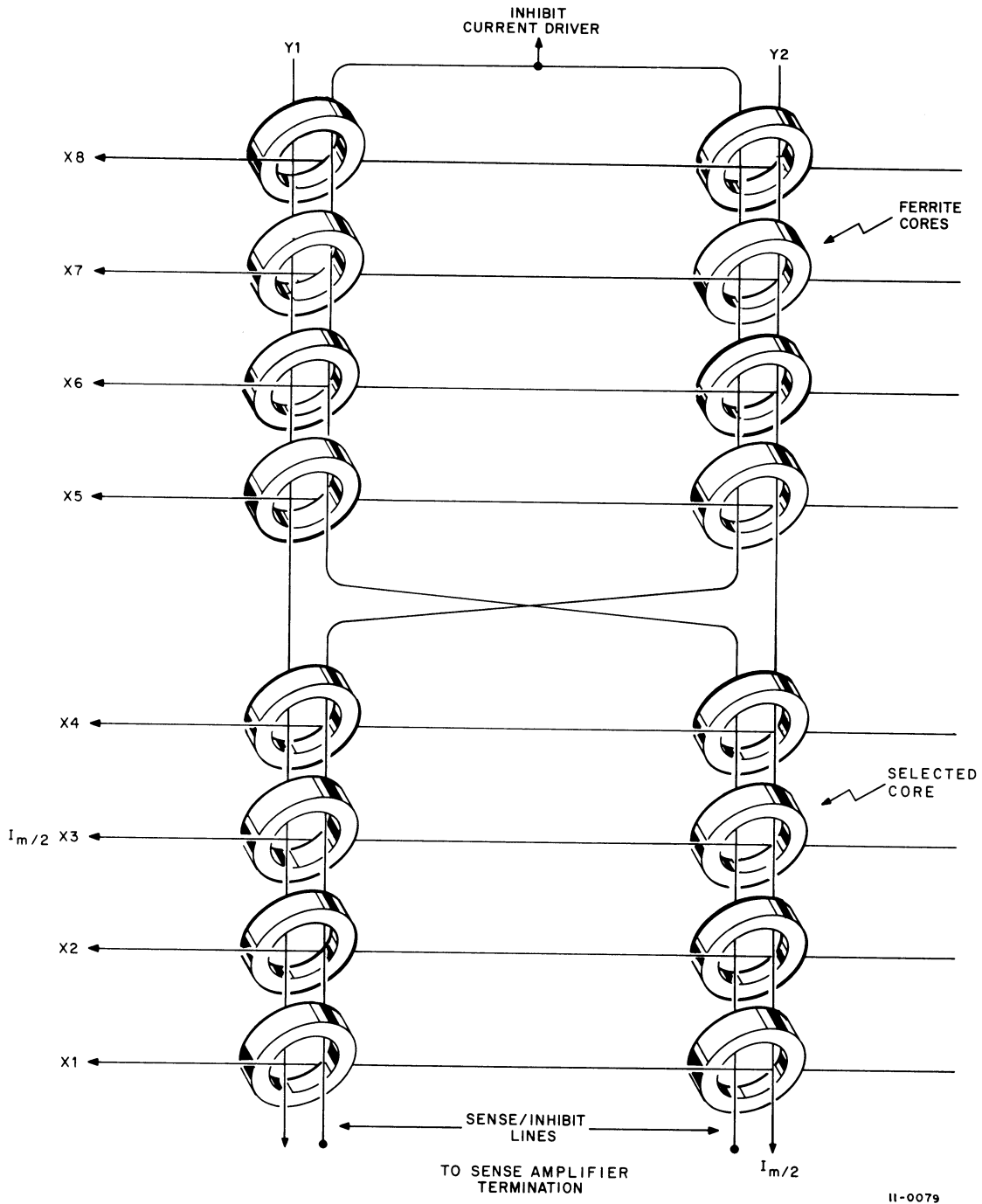
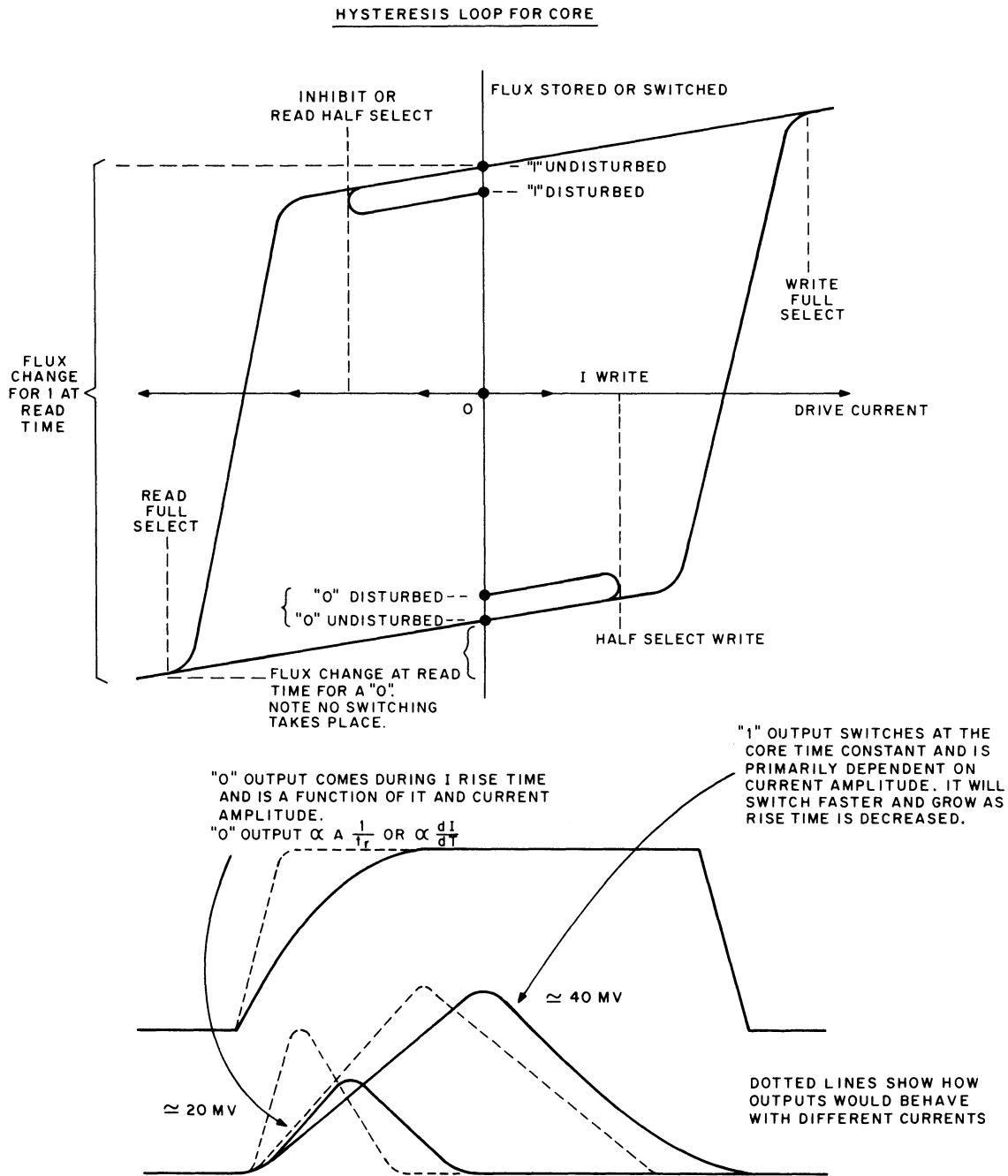

Figure 12-1 Three-Wire Memory Configuration

the selected core and the combined current values are sufficient to change the state of the core. The arrows in Figure 12-1 show current direction for the write cycle. All X- and Y-windings are arranged in such a manner that whenever a half-select current is passed through each, the resultant magnetic fields combine in the core at the point of intersection. This combined, full-select current ensures that the selected core is left in the binary 1 state. The currents used to select the core are referred to as write currents. A typical hysteresis loop for a core is shown in Figure 12-2.



11-0088B

Figure 12-2 Hysteresis Loop for Core

In the MM11-K and L Core Memories, the X3 windings in all 16 mats are connected in series as are the Y2 windings. Therefore, whenever a full-select current flows through a selected core on one mat, it also flows through an identical core on the other 15 mats. The X3-Y2 cores on all mats switch to a binary 1, causing each of the 16 cores to become one bit of a 16-bit storage cell.

Because of the serial nature of the X-Y windings, a method is used that allows cores to remain in the 0 state during a write operation; otherwise, every 16-bit word selected would be all 1s. The method used in the MM11-K and L Core Memories is to first clear all cores to the 0 state by reading and then, by using an inhibit winding during the write operation, to inhibit cores on particular mats. The inhibited cores remain 0s even when identical cores on other mats are set to 1.

The half-select current for the inhibit lines is applied from an inhibit current driver, which is a switch and a resistor between the inhibit line and -15V. The current in the inhibit line flows in the opposite direction from the write current in all Y-lines and cancels out the write current in any Y-line. There is a separate inhibit driver for each memory mat, and each mat represents one bit position of a word; thus, selected bits can be inhibited to produce any combination of binary 1s and 0s desired in the 16-bit word. It must be remembered that the inhibit function is active only during write time.

The sense/inhibit lines are also used to read out information in a selected 16-bit memory cell. The specific core is selected at read time in the same manner as during the write cycle with one notable exception: the X- and Y-currents are in the opposite direction. These opposite half-select currents cause all cores previously set to 1 to change to 0; cores previously set to 0 are not effected. Whenever the core changes from 1 to 0, the flux change induces a current in the sense winding of that mat. This current is detected and amplified by a sense amplifier. The amplifier output is strobed into the data register for eventual transfer to the Unibus. Figure 12-3 shows a 16-word by 4-bit planar memory. The MM11-L Core Memory (8K) functions in the same manner, except that it has 128 X-lines, 64 Y-lines, and 16 core mats. The core stringing is identical, and the sense windings are strung through all 8192 cores with the interchange between X63 and X64 instead of between X1 and X2. For the 4K memory, the interchange is between X31 and X32 and it has 64 X-lines and 64 Y-lines.

12.4 DEVICE AND WORD SELECTION

When the processor or a peripheral device attempts to perform a transaction with the memory, the processor asserts an 18-bit address on Unibus address lines A (17:00). Six of these 18 bits [A01 and A (17:13)] indicate the address of the memory as a device. Depending on the memory configuration, only four or five bit combinations of these bits are used as shown in Table 12-1. Eleven of the 12 remaining bits [A (12:02)] plus A01 and A13 indicate the address of a specific word within the memory. Address bit A00 is used to select the byte (8 bits) transaction when in DATOB mode.

Table 12-1
Addressing Functions

Bus Address	Function	
	4K Mode	8K Mode
A00	Controls byte mode	Controls byte mode
A01	Becomes A01H to G231	Becomes A01H to G231
A02, A03, A01H*	Decode Y-Drivers	Decode Y-Drivers
A04, A05, A06	Decode Y-Switches	Decode Y-Switches
A07, A08, A09	Decode X-Drivers	Decode X-Drivers
A10, A11, A12	Decode X-Switches	Decode X-Switches
A13	Goes to device selector	Decode X-Switches
A14	Goes to device selector	Goes to device selector
A15, A16, A17	Goes to device selector	Goes to device selector

*A01H is not a Unibus signal.

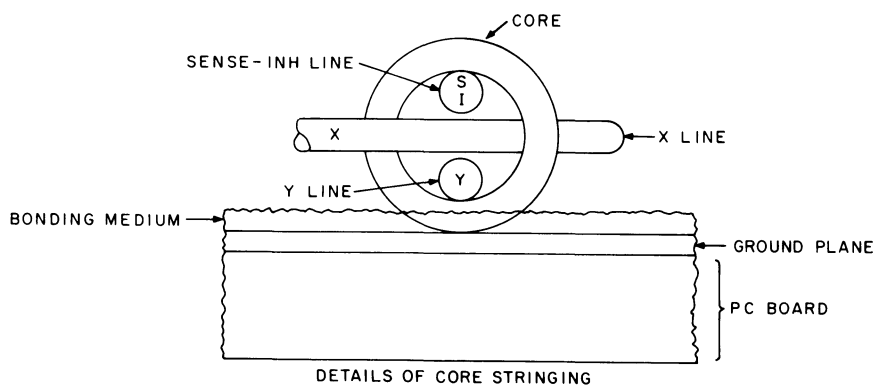
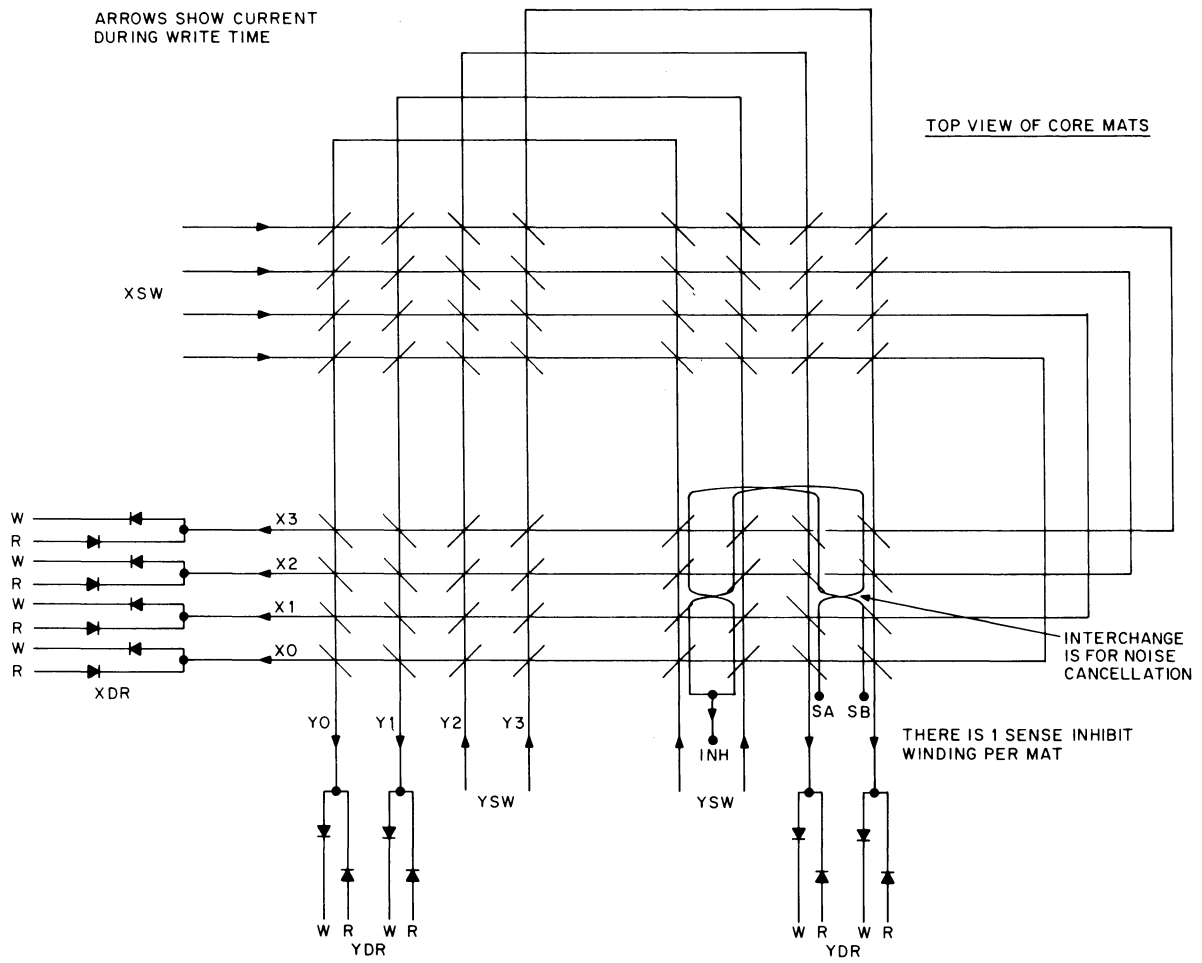

11-0088A

Figure 12-3 Three-Wire 3D Memory, Four Mats Shown for a 16-Word 4-Bit Memory

The memory address is decoded by the device selection circuit on the G110 Control Module. The word address is stored in a register on the G231 Driver Module whose output is decoded to activate the X-Y line switches and drivers which select the addressed word. These circuits contain jumpers which are included or excluded to establish a specific device address and select 4K- or 8K-word capacity. Jumpers are provided to select interleaved or non-interleaved operation for the 8K model; however, the memory is to be operated in the non-interleaved mode only.

Table 12-1 lists the function of each address bit. Figure 12-4 is a simplified block diagram of the device and word address selection circuits.

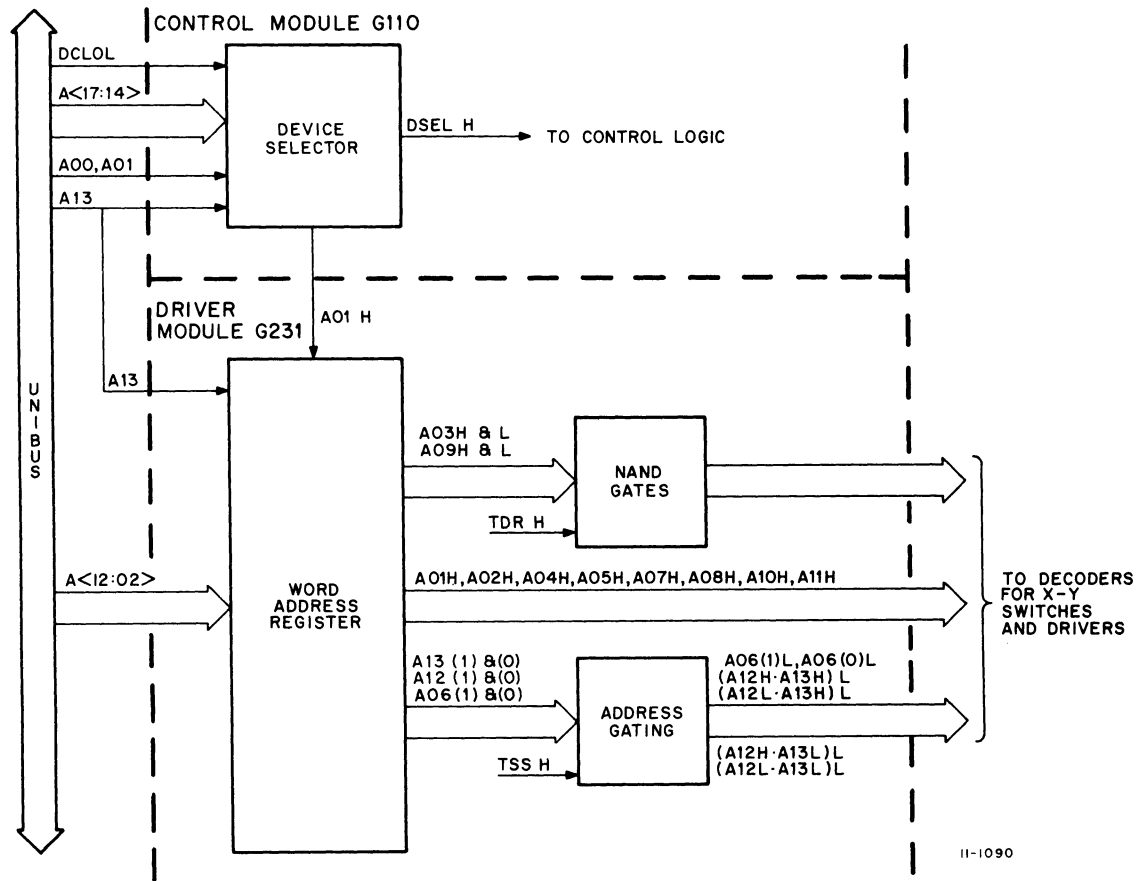
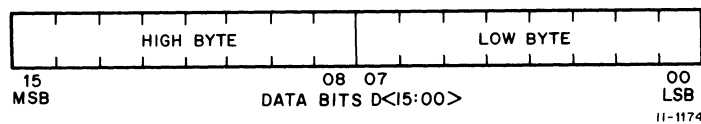

Figure 12-4 Device and Word Address Selection Logic, Block Diagram

12.4.1 Memory Organization and Addressing Conventions

Prior to a detailed discussion of the address selection logic, it is important to understand memory organization and addressing conventions.

The memory is organized in 16-bit words each consisting of two 8-bit bytes. The bytes are identified as low and high as shown below.



Each byte is addressable and has its own address location: low bytes are even numbered and high bytes are odd numbered. Words are addressed at even numbered locations only; the high (odd) byte is automatically included.

For example, an 8K word memory has 8192 words or 16,384 bytes; therefore, 16,384 locations are assigned. The address locations are specified as 6-digit octal numbers. The 16,384 locations for the 8K memory are designated 000000 through 037777. Figure 12-5 shows the organization for an 8K memory.

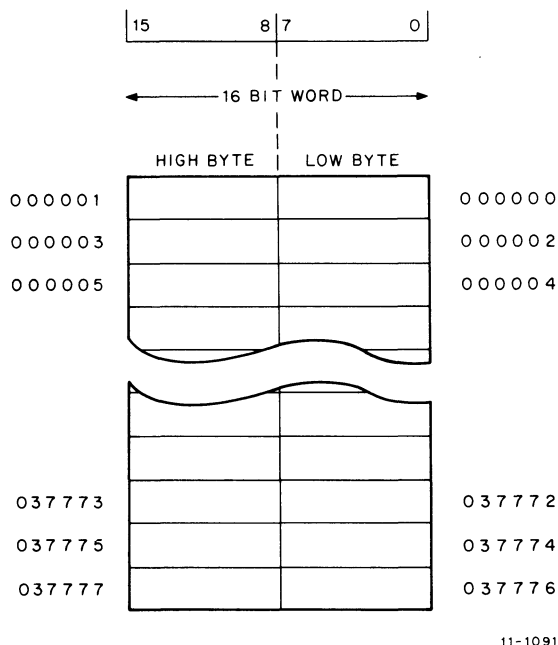

Figure 12-5 Memory Organization for 8K Words

The address selection logic responds to the binary equivalent of the octal address. The binary equivalent of 017772 is shown in the following example.

ADDRESS BITS A<17:00>																	
17	16	15	14	13	12	11	10	09	08	07	06	05	04	03	02	01	00
0	0	0	0	0	1	1	1	1	1	1	1	1	1	1	0	1	0
0			1			7			7			7			2		
BIT POSITION																	
BINARY																	
OCTAL																	

11-1173

Each memory bank (4K or 8K words) requires its own unique device address. For example, assume that a system contains three 8K memory banks (Figure 12-6). The device selector for the 8K non-interleaved memory decodes four address lines [A (17:14)]. Examination of the binary states of these bits for the three memory banks shows that the changes in the states of bits A14 and A15 allow the selection of a unique combination for each bank. The combination, which is the device address, is hardware-selected by jumpers in the device selector.

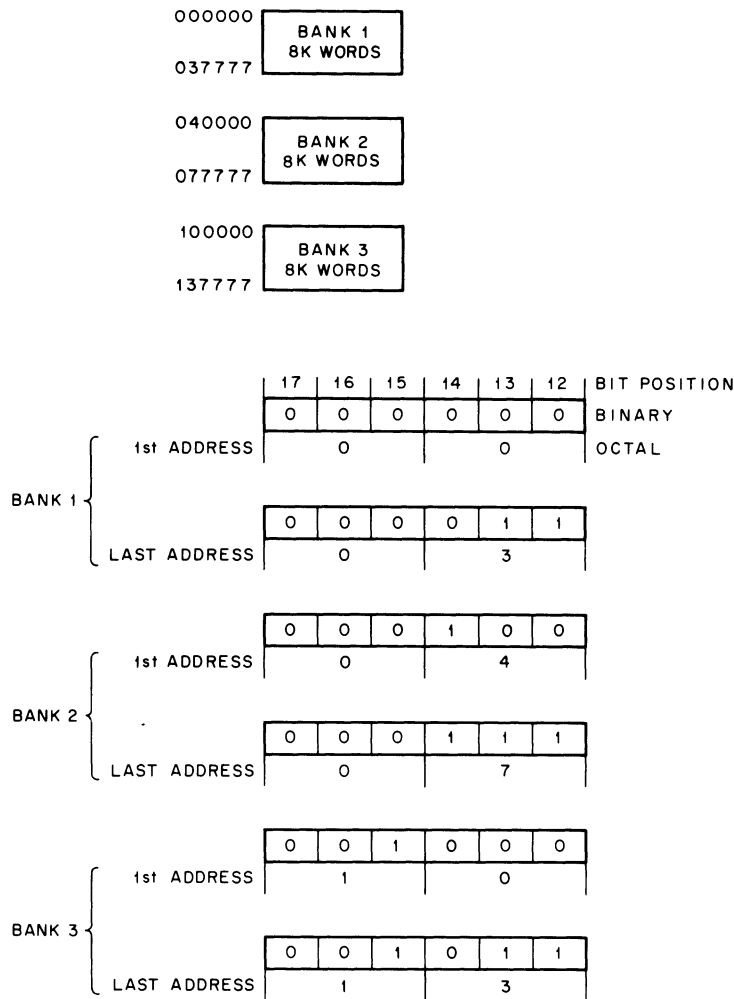

11-1092

Figure 12-6 Address Assignments For Three Banks of 8K Words Each

During system operation, the processor generates the binary equivalent of the octal address on Unibus address lines A (17:00). The processor uses positive logic and the Unibus uses negative logic. With this in mind, the following is included to remind the reader of the negative logic convention of the Unibus.

Processor (Positive Logic)

Signal Asserted: High = Logical 1 = +3V

Signal at Rest: Low = Logical 0 = 0V

Unibus (Negative Logic)

Signal Asserted: Low = Logical 1 = 0V

Signal at Rest: High = Logical 0 = +3V

12.4.2 Device Selector

The device selector located on the G110 Control Module (drawing G110-0-1, sheet 2) shows a logic diagram of the device selector in the 4K configuration.

Address bits A01 and A (17:13) are decoded in the device selector to provide the device selection signal D SEL H that is used in the control logic. Two combinations of these bits are decoded, depending on the memory configuration as shown below.

Memory Configuration	Address Bits
4K Words	A (17:13)
8K Words	A (17:14)

Obviously, the memory capacity is determined by the stack module: H213 for 4K words and H214 for 8K words. The same control module is used for both 4K and 8K memories; therefore, two jumpers (W9 and W10) are provided to include or exclude address bit A13 commensurate with the memory word size. Two jumpers (J3 and J4) on the G231 Driver Module (drawing G231-0-1, sheet 2) are provided for A13 inclusion or exclusion in the word addressing logic. The same driver module is used for both memory capacities. In the 4K word size, the components associated with the additional X-line read and write switches needed for 8K words may be removed. Two jumpers (W7 and W8) in the device selection logic on the control module are used to select interleaved or non-interleaved operation of the 8K memory. They are configured to provide non-interleaved operation only.

Each memory bank (4K or 8K) must have its own unique device address. Five jumpers (W2-W6) in the device selector provide this capability. On drawing G110-0-1, sheet 2, all the jumpers are shown in place and the device selector responds only when high signals appear on the Unibus address lines A (17:13). Some jumpers can be removed to allow the device selector to respond to a particular combination of high and low signals on these address lines.

All highs at the inputs of the 7380 Unibus receivers (E12 and E23) give lows at their outputs. Each receiver output goes to one input of a type 8242 Exclusive-NOR gate. Because of jumpers W7 and W8, bit A14 is decoded for 4K and 8K configurations. An additional receiver is used to sense BUS DC LO L, and its output (E23 pin 14) is sent to an 8242 gate (E24 pin 5). BUS DC LO L is asserted only when the dc voltages from the power supply drop below specified limits.

The other input of the 8242 gates associated with bits A14, A13, A15, A16 and A17 can be connected to +5V or ground, depending on whether or not jumpers W2-W6 are installed. The input is low (ground) with the jumper in; with the jumper removed, the input is high (+5V). Each 8242 gate is used as a digital comparator; its output is high only when both inputs are identical. The 8242 gates have open collectors and they are connected in common; therefore, the comparator output D SEL H is high only when all gates detect matched inputs (both lows or both highs).

An installed jumper requires a low signal at the output of the 7380 Unibus receiver. The 7380 is connected as an inverter so this signal is reflected as a high on the Unibus (logical or asserted state for the Unibus). To configure the jumpers for a specific device address, find the binary equivalent of the assigned octal address and insert a jumper in each bit position that contains a 0. A specific jumper configuration is shown in Figure 12-7.

The previous discussion dealt with the 4K memory configuration of the device selector as shown in drawing G110-0-1, sheet 2. Address bits A (17:13) are decoded and the output of bit A01 Unibus receiver (E23 pin 2) is sent via jumper W8 to the word address register as A01 H.

In the 8K memory configuration, jumper W9 is removed and W10 is installed. This removes bit A13 from the input of Unibus receiver E12 on G110 and replaces it with +5V via resistor R107. This receiver output (pin 14) always remains low so that jumper W5 must remain installed to ensure a match on pins 12 and 13 of gate E13. The jumper configurations for memory systems up to 128K words are shown in Figure 12-8.

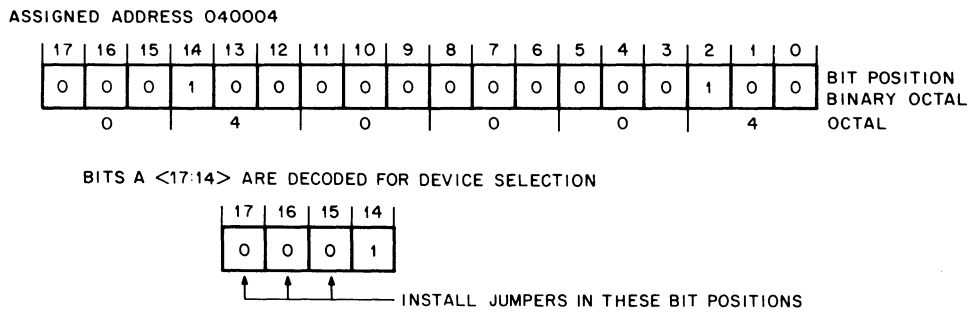
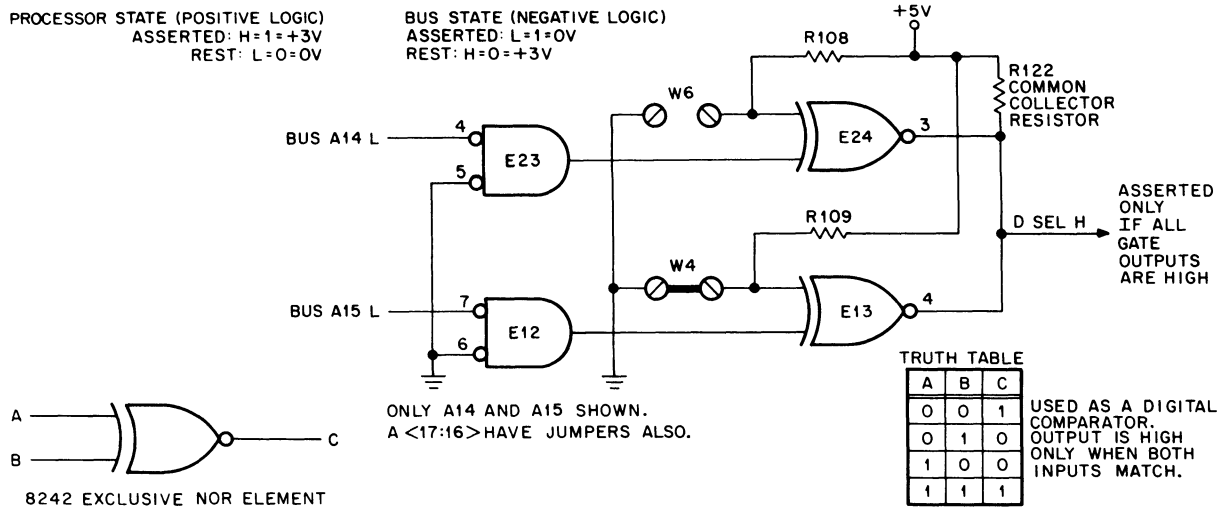

11-1093

Figure 12-7 Jumper Configuration For A Specific Memory Address

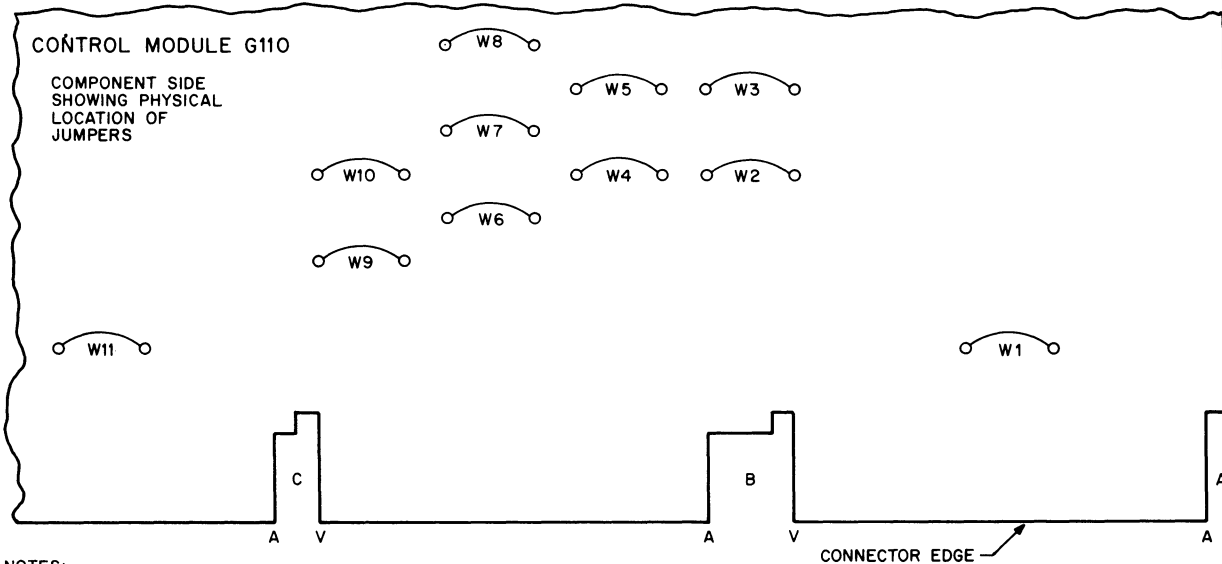

NOTES:

1. Jumper W1 is for test purposes only. It must be installed for normal operation.
2. Jumper W11 should be removed for normal operation. When installed the memory responds to DATI only, regardless of state of control lines CO0 and CO1.
3. Jumpers W7 and W8 must remain in the factory installed positions.
4. When used as an 8k bank, jumpers W5 and W10 must be installed and jumper W9 must be removed.
5. When used as a 4k bank, jumper W10 must be removed and jumper W9 must be installed. Jumper W5 determines the location of the bank on the bus.

11-1149

Figure 12-8 Device Decoding Guide

Memory Bank (Words)	Machine Address (Words)	Device Address Jumpers				
		W5 A13	W6 A14 or A01	W4 A15	W3 A16	W2 A17L
0-4K	000000-017776	IN	IN	IN	IN	IN
4-8K	020000-037776	OUT	IN	IN	IN	IN
8-12K	040000-057776	IN	OUT	IN	IN	IN
12-16K	060000-077776	OUT	OUT	IN	IN	IN
16-20K	100000-117776	IN	IN	OUT	IN	IN
20-24K	120000-137776	OUT	IN	OUT	IN	IN
24-28K	140000-157776	IN	OUT	OUT	IN	IN
28-32K	160000-177776	OUT	OUT	OUT	IN	IN
32-36K	200000-217776	IN	IN	IN	OUT	IN
36-40K	220000-237776	OUT	IN	IN	OUT	IN
40-44K	240000-257776	IN	OUT	IN	OUT	IN
44-48K	260000-277776	OUT	OUT	IN	OUT	IN
48-52K	300000-317776	IN	IN	OUT	OUT	IN
52-56K	320000-337776	OUT	IN	OUT	OUT	IN
56-60K	340000-357776	IN	OUT	OUT	OUT	IN
60-64K	360000-377776	OUT	OUT	OUT	OUT	IN
64-68K	400000-417776	IN	IN	IN	IN	OUT
68-72K	420000-437776	OUT	IN	IN	IN	OUT
72-76K	440000-457776	IN	OUT	IN	IN	OUT
76-80K	460000-477776	OUT	OUT	IN	IN	OUT
80-84K	500000-517776	IN	IN	OUT	IN	OUT
84-88K	520000-537776	OUT	IN	OUT	IN	OUT
88-92K	540000-557776	IN	OUT	OUT	IN	OUT
92-96K	560000-577776	OUT	OUT	OUT	IN	OUT
96-100K	600000-617776	IN	IN	IN	OUT	OUT
100-104K	620000-637776	OUT	IN	IN	OUT	OUT
104-108K	640000-657776	IN	OUT	IN	OUT	OUT
108-112K	660000-677776	OUT	OUT	IN	OUT	OUT
112-116K	700000-717776	IN	IN	OUT	OUT	OUT
116-120K	720000-737776	OUT	IN	OUT	OUT	OUT
120-124K	740000-757776	IN	OUT	OUT	OUT	OUT
124-128K	760000-777776	OUT	OUT	OUT	OUT	OUT

Figure 12-8 Device Decoding Guide (Cont)

12.4.3 Word Selection

Word selection requires two levels of decoding. The word address bits are placed in the 13-bit word address register: 12 bits are used for a 4K memory, and 13 bits are used for an 8K memory. Some bits from the register output are combined in a gating network. The outputs from the gating network and some outputs directly from the register are used as inputs to a group of decoders (Figure 12-4). The outputs of the decoders select the proper X- and Y-read/write switches and drivers.

12.4.3.1 Word Address Register and Gating Logic – The word address register and gating logic are contained on the G231 Driver Module. The circuit schematic is shown in drawing G231-0-1, sheet 2. The register is composed of 13 74H74 dual D-type edge-triggered flip-flops. They are identified as E11, E12, E13, E14, E18, E19, and E20. The output (pin 3) of gate E9 provides a high signal on the preset input (pin 4 or pin 10) of each flip-flop, which prevents direct presetting of the flip-flop. Direct clearing of each flip-flop is prevented by a high signal on the clear input (pin 1 or pin 13) via the output (pin 2) of gate E9. The register cannot be directly cleared or preset; its output responds only to the signal at its data (D) input.

Address bits A (13:02) are picked off the Unibus via type 7380 receivers (E15, E16, and E17). The receiver outputs are sent to the corresponding flip-flop D-inputs. The input to the receiver associated with bit A13 has two sources: Unibus signal BUS A13 L via jumper J4, or +5V via jumper J3. These jumpers are associated with the memory word size. A 4K memory requires J3 in and J4 out; an 8K memory requires J4 in and J3 out. Because BUS A13 L is used on the G110 module as part of the device selector, this arrangement prevents loading BUS A13 L twice per memory bank.

The E11 flip-flop associated with bit A01 receives its input from the device selector (drawing G110-0-1, sheet 2). The input signal is A01 H, which is obtained from bit A01 Unibus receiver for both 4K and 8K memories.

The register flip-flops are clocked synchronously by CLK 1 H from the control logic (drawing G110-0-1, sheet 2). Clocking occurs on the positive-going edge of CLK 1 H. The generation and timing of this clock signal is discussed in Paragraph 12.9.1. When the register is clocked, the outputs of flip-flops A01, A02, A04, A05, A07, A08, A10 and A11 are sent to the type 8251 X-Y decoders on the G231 Driver Module (drawing G231-0-1, sheets 3 and 4). The outputs of flip-flops A06, A12, and A13 are combined in a group of six type 74H10 NAND gates (three E22s, and three E25s), which are enabled by signal TSS H. Table 12-2 lists the states of flip-flops A06, A12, and A13 that are required to enable these gates. The outputs of flip-flops A03 and A09 are gated with TDR H in high-speed 2-input NAND gates and then applied to the decoders for the drivers only. The six signals listed in Table 12-2 are sent only to the X-Y line read/write switch decoders on the driver module.

Table 12-2
Enabling Signals for Word Register Gating

Output Signals		Enabling Signals		
Gate	Asserted Signal	FF A06	FF A12	FF A13
E22 pin 12	(A06H) L	Set	X	X
E22 pin 8	A06L	Reset	X	X
E22 pin 6	(A12H · A13H) L	X	Set	Set
E25 pin 12	(A12L · A13H) L	X	Reset	Set
E25 pin 8	(A12H · A13L) L	X	Set	Reset
E25 pin 6	(A12L · A13L) L	X	Reset	Reset

Signal ISS H is generated at the output (pin 3) of negative input OR gate E4 during a read or write operation. During a read operation, the enabling signal is produced at NAND gate E4, pin 8 by ANDing READ H and TNAR H. During a write operation, the enabling signal is produced at NAND gate E4, pin 6 by ANDing WRITE H and TWID H. Signals READ, TNAR and TWID are generated by the control logic on the G110 Control Module. WRITE is the complement of READ (produced by inverter E6). Signal READ H comes from the 1 output of R/W flip-flop E13 (drawing G110-0-1, sheet 2); the READ H signal is produced when the flip-flop is set. When the R/W flip-flop is cleared, READ H is low and is inverted by E6 to produce WRITE H.

12.4.3.2 X- and Y- Line Decoding – The basic decoding unit is a Type 8251 BCD-to-Decimal Decoder that converts a 4-bit BCD input code to a one-of-ten output; however, only eight outputs are used. Figure 12-9 shows an 8251 and associated truth table. The inputs are D0, D1, D2, and D3; they are weighted 1, 2, 4, and 8 with D0 being the least significant bit. The outputs are 0–7 and are mutually exclusive. The selected output is low and all others are high.

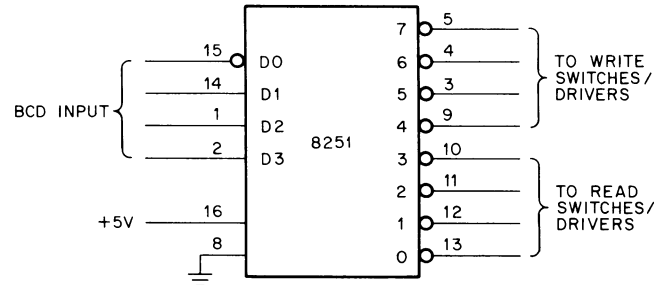

TRUTH TABLE

INPUTS				OUTPUTS							
D3	D2	D1	D0	0	1	2	3	4	5	6	7
0	0	0	0	0	1	1	1	1	1	1	1
0	0	0	1	1	0	1	1	1	1	1	1
0	0	1	0	1	1	0	1	1	1	1	1
0	0	1	1	1	1	1	0	1	1	1	1
0	1	0	0	1	1	1	1	0	1	1	1
0	1	0	1	1	1	1	1	1	0	1	1
0	1	1	0	1	1	1	1	1	1	0	1
0	1	1	1	1	1	1	1	1	1	1	0
1	X	X	X	1	1	1	1	1	1	1	1

X = IRRELEVANT

11-1095

Figure 12-9 Type 8251 Decoder, Pin Designation and Truth Table

For the 8K memory, ten decoders are used: six for the X-axis and four for the Y-axis. Each decoder controls four read/write switch pairs. Each pair is associated with a specific switch or driver. This switch matrix is combined with the stack X-Y diode matrix to allow selection of any location out of the total 8192 locations (stack drawing DCS-H214-0-1 for interconnections).

For the 4K memory, eight decoders are used, four for each axis. The stack X-diode matrix is halved to allow selection of any location out of the total 4096 locations (stack drawing DCS-H213-0-1 for interconnections). A discussion of the configuration and operation of the switches and diode matrices is given in Paragraph 12.4.3.3.

The X- and Y-line switches are first differentiated as switches and drivers. The drivers are those switches that are connected to the diode end of the stack. Drivers and switches are further differentiated by function: either read or write. Another differentiation is made by polarity: negative or positive, depending on the physical connection. Read drivers and write switches are connected to the current generator outputs and are considered positive; write drivers and read switches are connected to -15V and are considered negative.

Figure 12-10 shows the decoders associated with Y-line read and write switches 4–7 and Y-line read and write drivers 4–7. (Refer also to the truth table in Figure 12-9.) In both decoders (E28 for switches and E8 for drivers), the signal to input D3 selects the block of switch pairs. This signal must be low for any output to be selected. The signal to input D2, which is READ L for all decoders, controls the selection of read or write switches/drivers. When

READ L is low, outputs 0–3 are selected: these are read switches and read drivers. When READ L is high, outputs 4–7 are selected: these are write switches and write drivers. The four combinations of the states of inputs D0 and D1 select the particular switch/driver.

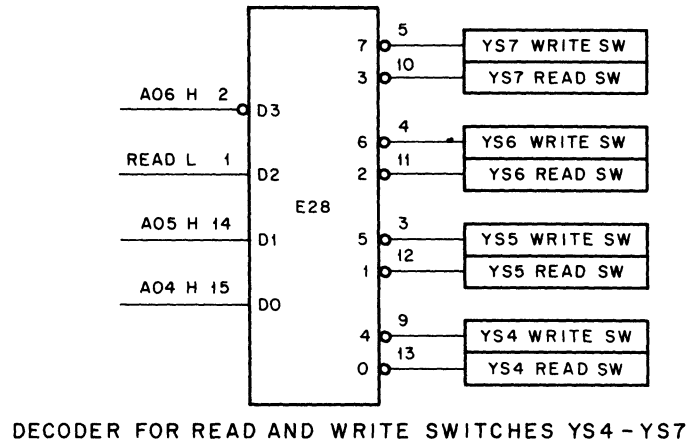

DECODER FOR READ AND WRITE SWITCHES YS4 - YS7

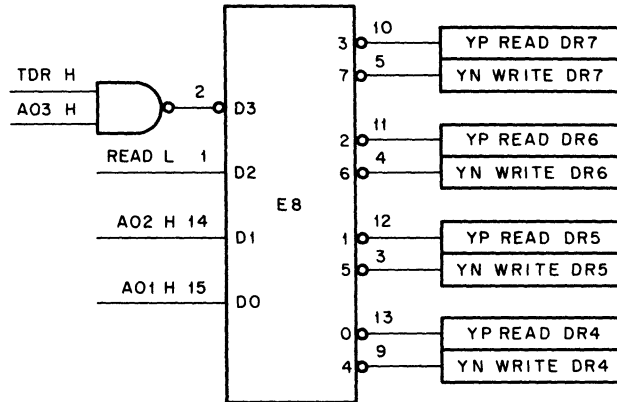

DECODER FOR READ AND WRITE DRIVERS Y4 - Y7

11-1096

Figure 12-10 Decoding of Read/Write Switches and Drivers Y4-Y7

The four driver decoders (E3, E8, E43, and E46 on drawing G231-0-1, sheets 3 and 4) have a NAND gate connected to input D3. Signal TDR H is an input to each gate; therefore, the driver decoders cannot be enabled unless TDR H is high. This signal is generated on the G231 Driver Module (drawing G231-0-1, sheet 2, coordinates A-8) by ANDing TWID H and READ H or TNAR H and WRITE H.

Each switch/driver is connected to the decoder output through a transformer-coupled base drive circuit. When the decoder output is at ground (low), the switch/driver is turned on; it is turned off when the decoder output is at +3.5V (high). The base drive circuit for write switch YS7 shown in Figure 12-11 is typical.

In this example, the decoder inputs have selected output 7, which is at ground. Current i_1 flows into this decoder output circuit from the +5V supply via resistor R11 and the primary winding (terminals 4 and 3) of transformer T8. The value of i_1 is determined by the value of R11 and the voltage reflected into the transformer primary (approximately 1V). An equal current i_2 is induced in the base-emitter circuit of write switch E29, which is

connected to the transformer secondary winding (terminals 13 and 14). This current turns on E29. All the base current for E29 is provided by this circuit: i_3 is the collector current. When the decoder is turned off, its output pull-up transistor tries to drive the turn-off current i_4 in the opposite direction. This reverse current removes the forward bias from the base of E29 and turns it off. Capacitor C30 allows the decoder to pump reverse current i_4 into the transformer primary; it also speeds up turn-on current i_1 . Diode D1 prevents reverse breakdown of the base-emitter junction of E29; it also protects the decoder output.

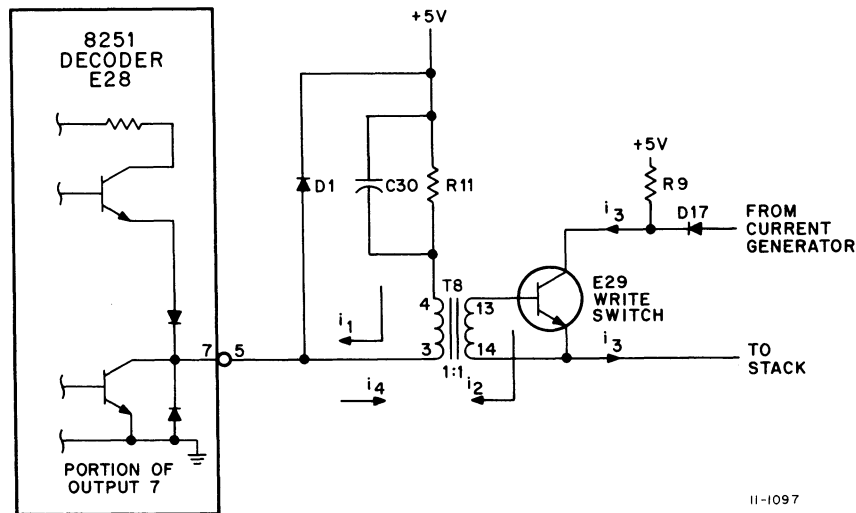

Figure 12-11 Switch or Driver Base Drive Circuit

12.4.3.3 Drivers and Switches – Drivers and switches direct the current through the X- and Y-lines in the proper direction as selected by the read and write operations.

For an 8K memory, 16 pairs of read/write switches and 8 pairs of read/write drivers are provided in the X-axis; 8 pairs of read/write switches and 8 pairs of read/write drivers are provided in the Y-axis. In conjunction with the stack diode matrix (drawing H214-0-1, sheet 2), one driver and any one of 16 switches select 16 lines in the X-axis; one driver and any one of eight switches select eight lines in the Y-axis. This allows selection of 128 lines in the X-axis and 64 lines in the Y-axis. This provides a 128 × 64 matrix that selects any location out of 8192 locations.

For a 4K memory, eight pairs of read/write switches and eight pairs of read/write drivers are provided for each axis (X and Y). One driver and any one of eight switches select eight lines in both axes, which allows selection of 64 lines in each axis and provides a 64 × 64 matrix that selects any location out of 4096 locations. The size of the X-diode matrix for the 4K memory is one half the size of the corresponding matrix for the 8K memory (drawing H213-0-1, sheet 2). In both memories, the diodes prevent sneak currents in the stack and steer all switched current into the selected stack line.

Figure 12-12 is one fourth of a Y-selection matrix showing the interconnection of the diodes and the lines from the switches and drivers. It also shows how four pairs of switches and drivers are connected to select 16 locations. Refer to drawing H213-0-1, sheet 2 for an extension of this method that uses eight pairs of switches and drivers to select 64 locations.

Figure 12-12 shows four pairs of drivers and four pairs of switches for the Y-axis only; polarities are shown for convenience. The diodes are identified to assist in associating them with the drivers and switches. Each line from a twin diode interconnection to a read/write switch pair passes through 64 cores and represents one line on each bit

mat. Assume that a write operation is to be performed and the word address decoders have selected write switch WYS00 and write driver YNWD1. The Y-current generator sends current through write switch WYS00 (conventional flow), which puts a positive voltage on the anodes of diodes 03W, 02W, 01W and 00W. The non-selected write drivers (YNWD3, YNWD2, and YNWD0) provide a positive voltage on the cathodes of their associated diodes (03W, 02W and 00W, respectively), which reverse biases them and prevents conduction. Write driver YNWD1, which has been selected, turns on and makes the cathode of diode 01W negative with respect to the anode that forward biases it. The diode conducts and allows current to flow to write driver YNWD1. A half-select current now flows through this line that links 64 cores per bit mat (1024 total for 16 mats).

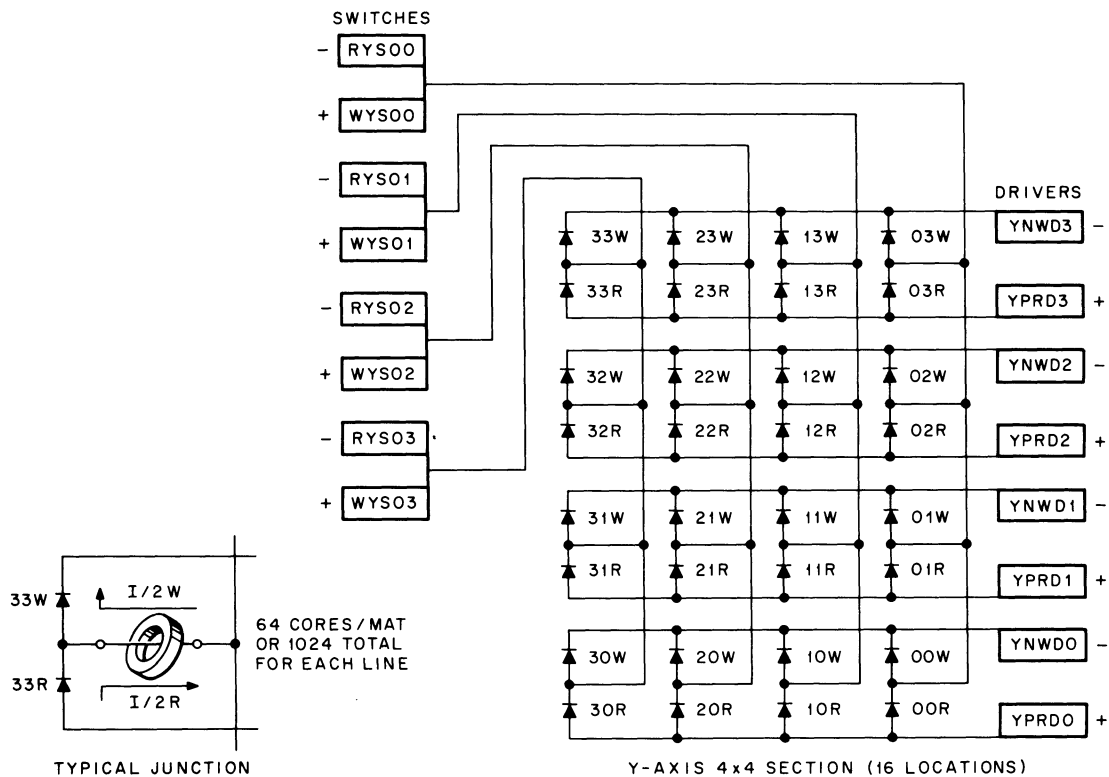

11-1098

Figure 12-12 Y-Line Selection Stack Diode Matrix

Figure 12-13 is a simplified schematic of two pairs of switches and drivers interconnected with the core stack and current generator. Read/write switches YS07 and read/write drivers YD7 are used as examples. These switches and drivers are chosen for convenience. For a read or write operation, there are 64 switch/driver combinations available on the Y-axis and 128 on the X-axis. For a read operation, decoder E8 selects positive read driver E7 via transformer T3; and decoder E28 selects negative read switch E26 via transformer T7. Both E7 and E26 are turned on when they are selected. E7 conducts and removes the reverse bias on diode D67, which allows current from the Y-current generator to flow through D67, E7, the associated matrix diode, and the cores on the selected line. After passing through the cores, the current flows through E26 and R27 to the -15V line. For a write operation, decoder E28 selects positive write switch E29 via transformer T8; and decoder E8 selects negative write drivers E10 via transformer T4. Both E29 and E10 are turned on. E29 conducts and removes the reverse bias on diode D17, which allows current from the Y-current to flow through D17, E29, and the cores in the opposite direction. After passing through the cores, the current flows through the associated matrix diode, E10, and R140 to the -15V line. Read current flow is shown as a solid line; a broken line shows write current flow.

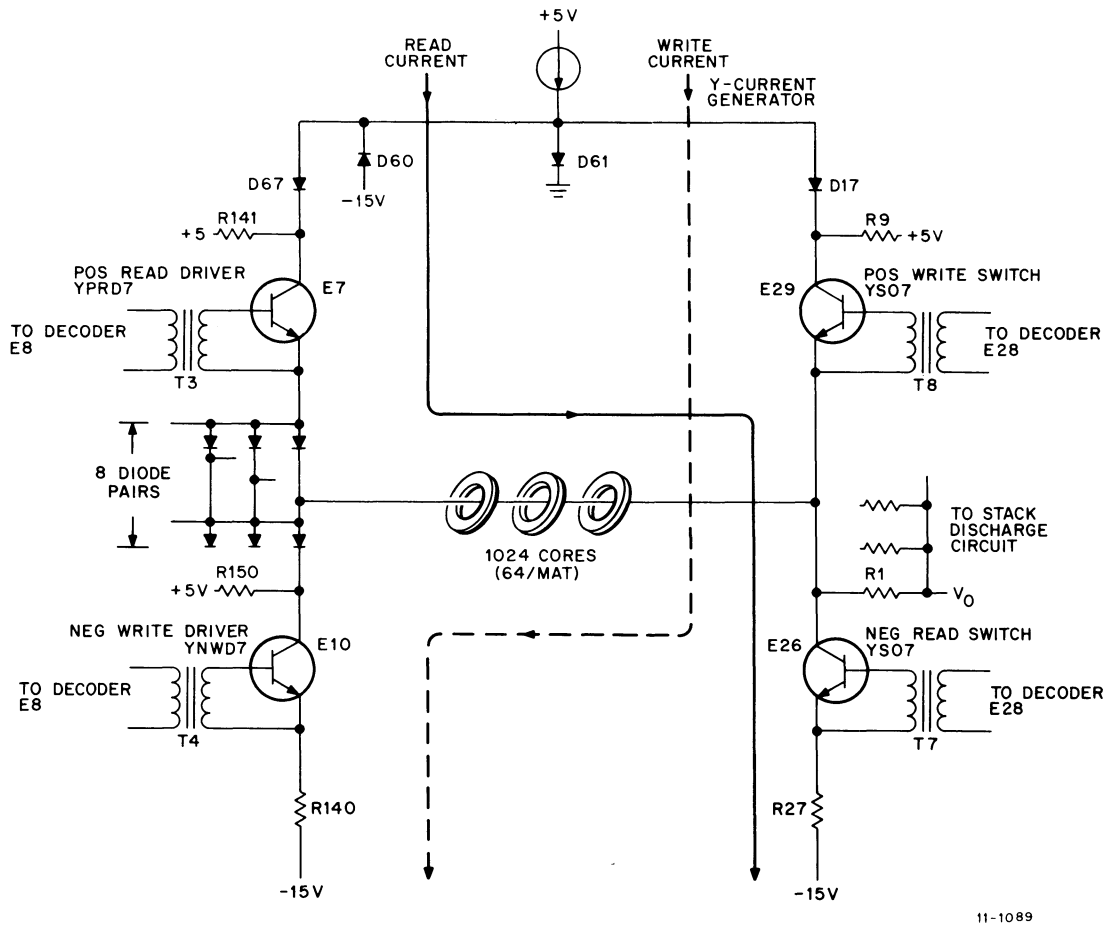

Figure 12-13 Typical Y-Line Read/Write Switches and Drivers

12.4.3.4 Word Address Decoding and Selection Sequence – This paragraph takes a specific word address through the decoding and X- and Y-line selection sequence.

The word address is 017772, and it is assumed that a specific memory bank has been selected. The binary equivalent of the address is shown below. A read operation is to be performed.

ADDRESS BITS A<17:00>

17	16	15	14	13	12	11	10	09	08	07	06	05	04	03	02	01	00	BIT POSITION	
0	0	0	0	0	1	1	1	1	1	1	1	1	1	1	0	1	0		BINARY
0		1			7			7			7			2					OCTAL

11-1173

Bits A (13:01) are used to decode the word address. Bit A01 is sent to the device selector (drawing G110-0-1, sheet 2) and appears at word address flip-flop E11, pin 2 as A01 H (drawing G231-0-1, sheet 2). Bits A (12:02) are sent to the Unibus receivers, which are inputs to the associated word address flip-flops. Bit A13 is not used. The input to the Unibus receiver associated with this bit is connected directly to +5V through jumper J3 (for a 4K memory, J3 is in and J4 is out). Table 12-3 shows the state of bits A (13:01) and the decoding signals generated by the word address flip-flops after they are clocked.

Table 12-3
Word Address Decoding Signals

Address Bit	Unibus Receiver Input	Receiver Output	Flip-Flop State	Flip-Flop Output Signals
A01	L	H	set	A01H = H
A02	H	L	reset	A02H = L
A03	L	H	set	A03H = H, A03L = L
A04	L	H	set	A04H = H
A05	L	H	set	A05H = H
A06	L	H	set	A06H = H, A06L = L
A07	L	H	set	A07H = H
A08	L	H	set	A08H = H
A09	L	H	set	A09H = H, A09L = L
A10	L	H	set	A10H = H
A11	L	H	set	A11H = H
A12	L	H	set	A12H = H, A12L = L
A13	-	-	reset	A13H = L, A13L = H

The output signals from flip-flops A06, A12, and A13 are not used directly from the flip-flops; they are sent to gating logic (E22 and E25) and are ANDed with signal TSS H. In this case, only two out of a possible six signals are generated: A06H is low from E22, pin 12 and (A12H . A13L) L is low from E25, pin 8. These signals and the outputs from the other word address flip-flops are sent to the inputs of the type 8251 decoders to select the appropriate switches and drivers. READ L is an input to each 8251 decoder. A read operation is to be performed; therefore, READ L is low.

The decoders, switches, and drivers are shown in drawing G231-0-1, sheets 3 and 4. Using the decoding signals in Table 12-3 and the operating characteristics of the decoders, it is possible to determine which decoders have been selected for word address 017772. A decoder is selected only when its D3 input is low. In this case, the selected decoders are E34 and E46 for the X-line (drawing G231-0-1, sheet 3), and E23 and E8 for the Y-line (drawing G231-0-1, sheet 4). READ L is low and is sent to input D2 of each decoder; it selects read drivers and switches in this case. To verify this point, refer to the truth table and diagram in Figure 12-9. Decoder inputs D0 and D1 select the particular switch or driver as shown below.

- a. Decoder E34
D1 is high, D0 is high: selects output 3 (pin 10), which is read switch XS07.
- b. Decoder E46
D1 is high, D0 is high: selects output 3 (pin 10), which is read driver XPRD7.
- c. Decoder E23
D1 is high, D0 is high: selects output 3 (pin 10), which is read switch YS03.
- d. Decoder E8
D1 is low, D0 is high: selects output 1 (pin 12), which is read driver XPRD5.

The last step is to follow the outputs of the drivers and switches to the stack diode matrix (drawing H213-0-1, sheet 2). For the X-line, the circuit is from driver XPRD7 to diode junction E7-11, across termination 35 to switch XS07.

For the Y-line, the circuit is from driver YPRD5 to diode junction E4-9, across termination 15 to switch YS03. The termination indicates the point on the stack printed circuit board where the X- or Y-line is soldered. Physically, the wire that is connected across the termination is strung through 64 cores per bit mat (total of 1024 cores in series for 16-bit memory).

12.5 READ/WRITE CURRENT GENERATION AND SENSING

In addition to the addressing and control logic, four functional units are involved in generating current to switch the cores and detect their state. The X- and Y-line current generators supply the drive current (via switches and drivers); the inhibit drivers allow 0s to be written during a write operation; the sense amplifiers detect 1s during a read operation; and the memory data register (MDR) temporarily stores data to be written or data that has been read from the memory. The following paragraphs describe each functional unit and their interrelationship.

12.5.1 Read/Write Operations

The read/write operations are discussed in terms of the interrelation of the current generator, inhibit drivers, sense amplifiers, and memory data register. Details of operation of each functional unit are discussed in subsequent paragraphs. Several control signals are mentioned; however, details of their generation and timing are described in Paragraph 12.8.

For clarity, one data bit (D07) of the selected word is discussed and the text is referenced to Figure 12-14, which is a simplified block diagram. Detailed logic for the memory data register (MDR), Unibus receivers and drivers, sense amplifiers, and inhibit drivers for all 16 data bits is shown on drawing G110-0-1, sheets 3 and 4.

During a read operation, half-select currents flow in the X- and Y-lines for the selected word in each bit mat. These currents flow opposite to the write currents; therefore, cores in the 1 state are switched to the 0 state, and cores in the 0 state are unchanged. Switching the core from the 1 state to the 0 state induces a voltage pulse in the sense winding. This pulse is detected by sense amplifier E52 as a differential voltage on input pins 6 and 7 that exceeds the threshold reference voltage. This pulse is amplified and when STROBE O H is generated at pin 11, the output of sense amplifier E52 goes high. Just prior to the strobe signal, the control logic generates RESET O L, which clears (resets) flip-flop E54. The sense amplifier output is inverted by E56 and sent to the preset input (pin 10) of MDR flip-flop E54. A low on the preset input sets the flip-flop: its 1-output (pin 9) is a high and its 0-output (pin 8) is a low. The high from pin 9 of the flip-flop is sent to input pin 1 of the Unibus driver E21. The other input to this gate is the data out signal. When the control logic generates DATA OUT H, the output of E21 is low (logical 0 for memory logic and logical 1 for Unibus logic). This is the readout of bit D07 and is sent to the requesting device via the Unibus. Timing diagrams for the sense operation are also shown in Figure 12-14.

The read operation is destructive: all cores at the specified location are now 0. The data that was read must be restored by a write operation, which immediately follows the read operation. Flip-flop E54 is still in the set state; therefore, its 0-output (pin 8), which is low, is sent to input pin 9 of NAND gate E53. The control logic generates the inhibit driver control signal TINHO H, which is the other input to gate E53. The gate is not asserted (pin 8 is high), and the inhibit driver is not turned on. With no inhibit current in the inhibit line to oppose the half-select Y-line current, a 1 is written back into the appropriate cores.

In this example, if bit D07 is a 0 in core, it does not switch during the read operation and the output of sense amplifier E52 does not go high. Flip-flop E54 remains cleared (reset): its 1-output (pin 9) is low and its 0-output (pin 8) is high. When the control logic generates DATA OUT H, the output of Unibus driver E21 is high (logical 1 for memory logic and logical 0 for Unibus logic). The 0-output of flip-flop E54, which is high, is sent to NAND gate E53. During the subsequent write operation, TINHO H is generated, producing a low output signal at E53, pin 8 to activate the inhibit driver which in turn produces a current that opposes the Y-line current and prevents a 1 from being written into this bit of the selected word.

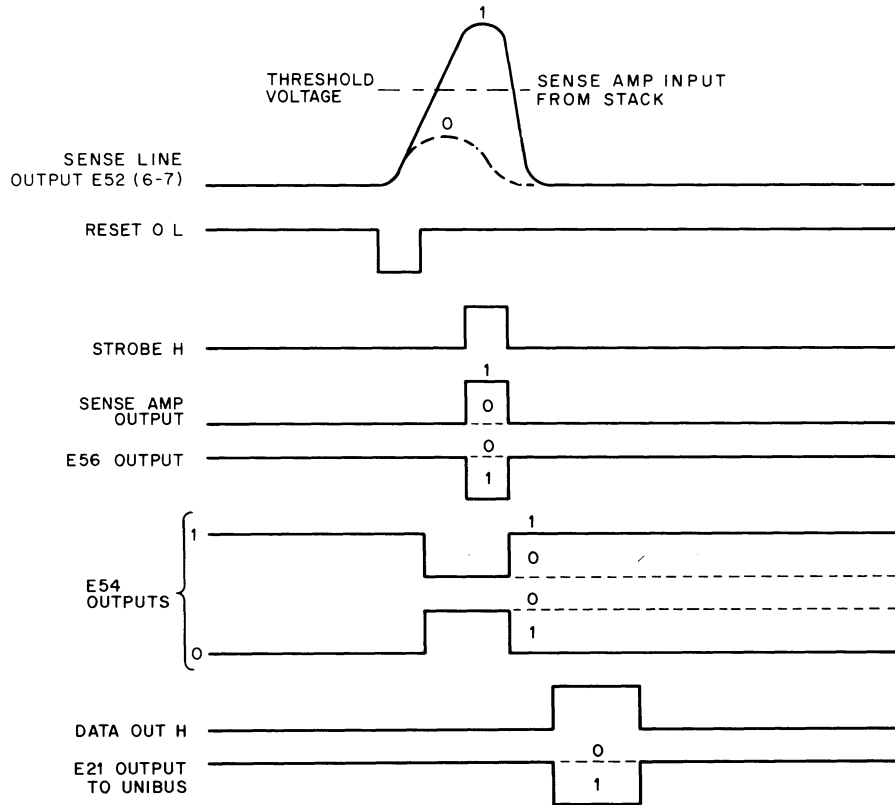
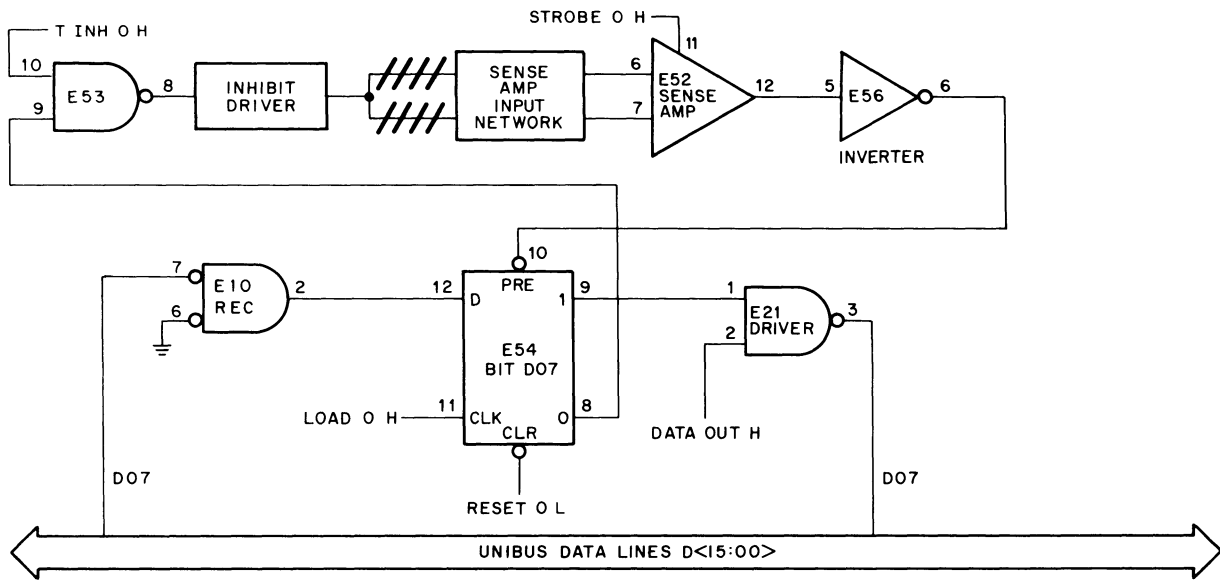

11-1100

Figure 12-14 Interconnection of Unibus, Data Register, Sense Amplifier, and Inhibit Driver

The read/write operation that has been discussed is a read/restore operation (DATI). The requesting device wants to read a word from memory, and as an internal requirement, the memory must restore the word by writing it back into core. In this case, the MDR flip-flops are preset by the sense amplifier outputs when 1s are read from the core. The MDR flip-flop outputs are used in the subsequent write (restore) operation to control the inhibit drivers. If the requesting device wants to write a word into memory (DATO), it must load the data into the MDR flip-flops. The

requesting device then asserts the data on the Unibus, from which it is picked off via Unibus receivers. In this example, bit D07 is sent to pin 7 of Unibus receiver E10. Bit D07 is inverted by the receiver and sent to the D-input (pin 12) of flip-flop E54. At the start of the DATO operation, the control logic generates LOAD O H, which clocks the flip-flop. If the D-input is high, E54 is set and its 0-output is low. Control gate E53 is not asserted by TINHO H, and the inhibit driver is not turned on. A 1 is written into the selected core. If the D-input is low, E54 is reset and its 0-output is high. Control gate E53 is asserted by TINHO H, and the inhibit driver is turned on. A 0 is written into the selected core. Because RESET and STROBE are inactive in this mode, the read operation is used only to magnetically clear all the cores to the 0 state.

12.5.2 X- and Y-Current Generators

Two identical current generators are provided: one each for the X- and Y-drive lines. They generate the current pulses that are used during read and write operations to switch the cores. The current generators and associated reference voltage supply are shown in drawing G231-0-1, sheet 2. Figure 12-15 shows the Y-current generator and reference voltage supply.

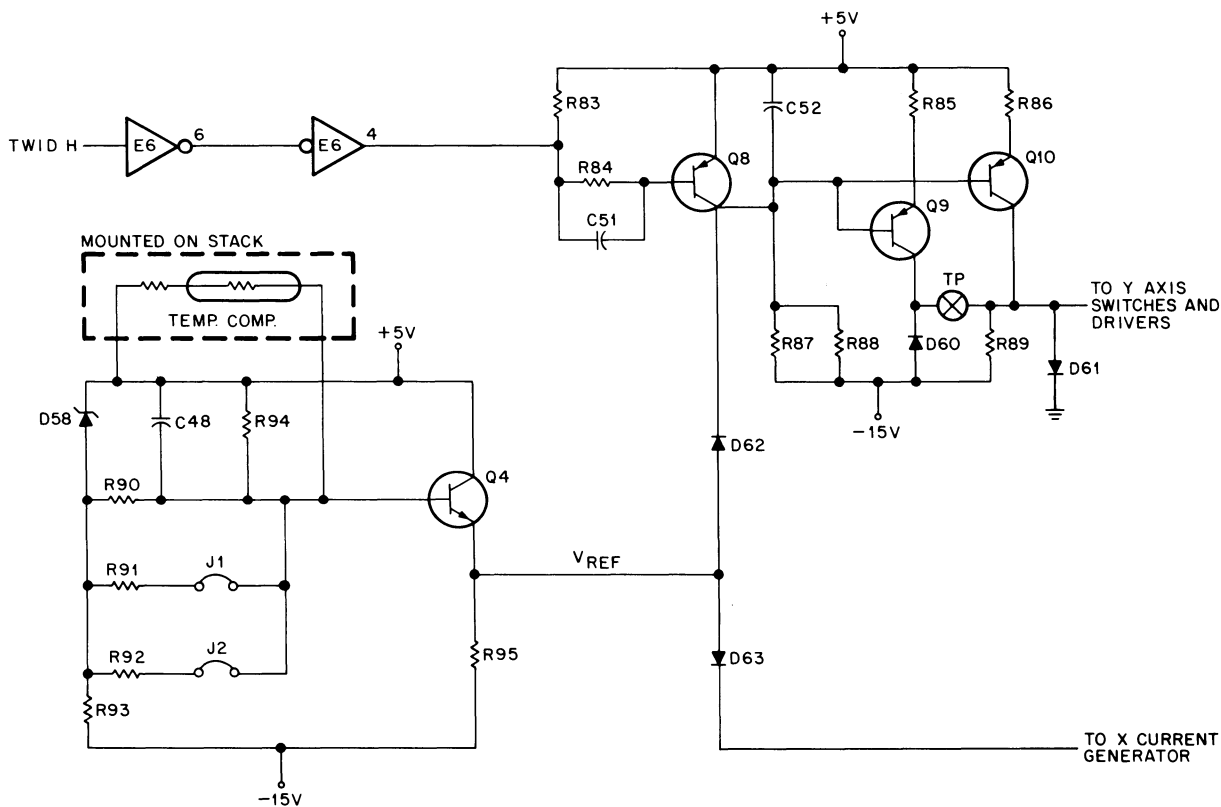

11-1101

Figure 12-15 Y-Current Generator and Reference Voltage Supply

Optimum core switching requires repeatable current pulses of constant amplitude with a linear rise time. The current generator and reference voltage circuit provide current pulses that meet these requirements. The amplitude of the output current pulse is determined by the reference voltage circuit; the rise time is determined by an RC circuit in the current generator; and pulse duration is determined by the length of the triggering pulse TWID H.

During the quiescent state of the current generator, input transistor Q8 is on; its collector voltage is 4.7V, and it is connected to the cathode of diode D62, which reverse biases it. The anode of D62 is connected to the emitter of transistor Q4, which is the output of the reference voltage circuit. In this state, D62 blocks the output from the reference voltage circuit to the current generator. With Q8 on, both output transistors Q9 and Q10 are turned off, and the current generator is off.

Operation of the current generator is triggered by a high TWID H signal from the control logic. TWID H is double inverted by two E6 inverters and sent to the base of Q8, which turns it off. When Q8 is cut off, capacitor C52 starts charging, which provides base drive to output transistors Q9 and Q10 and they begin to conduct. With Q8 off, its collector goes negative until it reaches the forward bias level of D62, which is the value of the reference voltage minus the voltage drop across D62. The rise time of the current pulse is determined by the time constant of C52, R87, and R88. The amplitude of the pulse is determined by the value of the reference voltage. When TWID H goes low again, the current generator is turned off and the output pulse is terminated.

A resistor network in the base circuit of Q4 (in the reference supply) is used to set the amplitude of the current generator to approximately 410 mA. The total resistance of parallel network R90, R91, and R92 is changed by the configuration of jumpers J1 and J2. The amplitude of the current generator output pulse is factory set as close as possible to 410 mA at 25°C. It should not be changed in the field.

The base circuit of Q4 is temperature compensated by a resistor and thermistor that are mounted on the stack. This ensures that the amplitude of the current generator output pulse remains within specified tolerances over a temperature range of 0°C to 50°C. This temperature compensation is approximately -0.8 mA/°C.

12.5.3 Inhibit Driver

A detailed schematic of the inhibit driver for bit D07 is shown in Figure 12-16; it is typical of all 16 inhibit drivers (drawing G110-0-1, sheets 3 and 4).

When the inhibit driver is off, none of the currents shown in the schematic are flowing. Transistor Q7 is held off by the negative voltage on its base. The output of NAND gate E53 goes low (ground) when this inhibit driver is selected. Current i_1 flows into the output circuit of E53 from the +5V supply via resistor R87 and the primary winding (terminals 15 and 16) of transformer T8. An equal current is induced in the base-emitter circuit of Q7, which is connected to the transformer secondary winding (terminals 1 and 2). This base current overcomes the reverse bias voltage and turns on Q7. Current i_1 and therefore induced-current i_2 are determined by resistor R87 and the reflected base-emitter voltage V_{be} of Q7. When Q7 is turned on, current flows from ground through Balun transformer T7, isolation diodes D13 and D14, and the sense/inhibit winding to the common inhibit terminal (07IN). The Balun transformer balances the two inhibit half-currents. At terminal 07IN, the full inhibit current flows through resistor R72 and Q7 to -15V. The value for the inhibit current is calculated as follows:

$$i_{inh} \cong \frac{15V - V_{ce\ sat\ Q7} - V_{be\ diodes}}{R72 + R_{core\ mat}}$$

$$\cong \frac{15 - 0.8 - 1.2}{17.5} = 740\text{ mA}$$

Each leg of the sense/inhibit winding sees half the inhibit current: approximately 370 mA. Capacitor C55 decreases the rise time of the current.

The inhibit driver is turned off when the output (pin 8) of gate E53 goes from low to high. At turn-off time, the back emf caused by the stack inductive reactance tries to drive the collector of Q7 highly positive; however, diode D43 clamps this voltage to ground. When the output of E53 goes high (approximately +3.2V), its output pull-up transistor (an integral part of the gate circuit) tries to drive the turn-off current i_4 in the opposite direction through the transformer primary winding. An equal current induced in the secondary winding removes the forward bias from

the base of Q7 and turns it off. With Q7 off, all dynamic current flow ceases in the circuit and the negative voltage on the base of Q7 keeps the circuit turned off until the output of gate E53 goes low again.

Capacitor C74 allows the gate to pump reverse current i_4 into the transformer primary; it also helps to decrease the turn-on time of Q7. Diode D59 prevents reverse breakdown of the emitter junction of Q7.

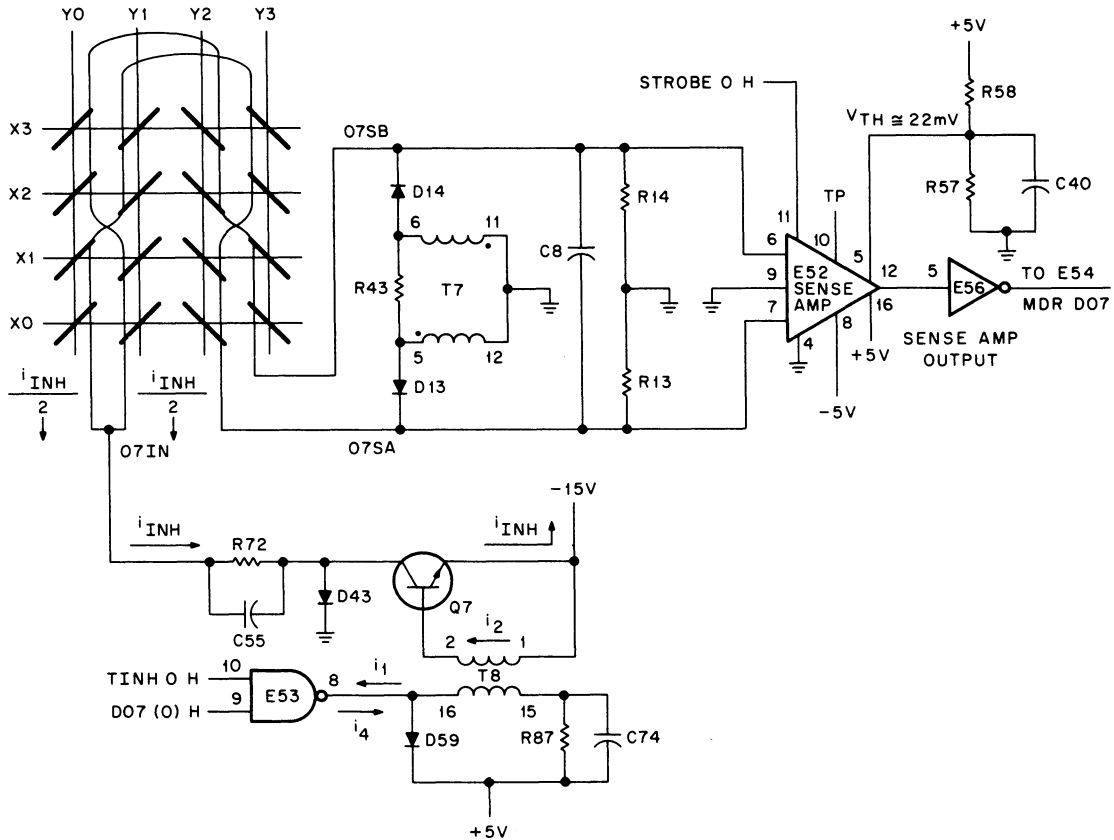

11-1102

Figure 12-16 Sense Amplifier and Inhibit Driver

12.5.4 Sense Amplifier

A detailed schematic of the sense amplifier circuit for bit D07 is shown in Figure 12-16; this circuit is typical of all 16 sense amplifier circuits (drawing G110-0-1, sheets 3 and 4). The circuit consists of the sense amplifier, terminating network for the sense/inhibit winding, and threshold voltage network.

The sense amplifier input (E52, pin 6 and 7) is across the sense/inhibit winding (points 07SB and 07SA). Resistors R13 and R14 are matched to terminate the sense/inhibit line in the desired impedance. Practically speaking, during the sense operation, the inhibit driver connection is an open circuit through the driver transistor Q7. The effect of the inhibit driver circuit, Balun transformer T7, and isolation diodes D13 and D14 can be ignored during the sense operation, because the diodes are reverse biased.

Sense amplifier E52 is one half of a dual IC package (type 7528). A simplified block diagram of the package is shown in Figure 12-17. The two identical circuits are marked 1 and 2. Each one consists of a preamplifier and sense

amplifier. The output of the preamplifier is available as a test point to observe the amplified core signal and to facilitate accurate strobe timing. Both circuits share a reference voltage (or threshold voltage) amplifier (pins 4 and 5). In this application, pin 4 is grounded and a positive threshold voltage of approximately 20 mV is supplied to pin 5. This voltage is obtained from the +5V supply through resistor voltage divider R57 and R58; C40 is a bypass capacitor. Operation of the sense amplifier is discussed in Paragraph 12.5.1.

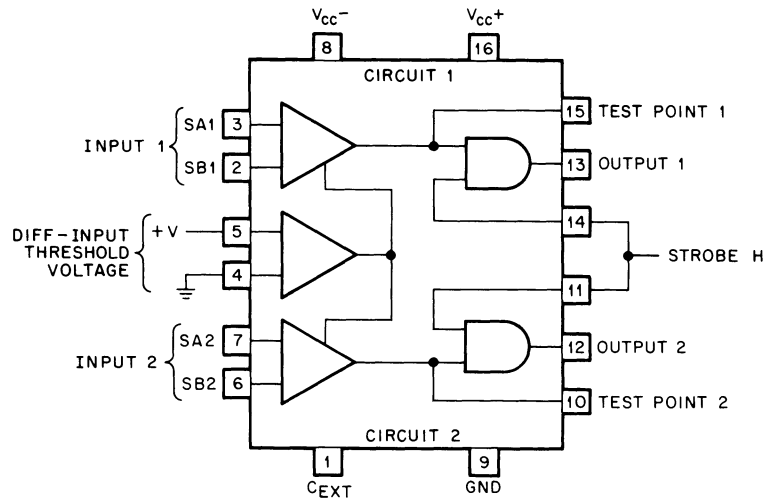

11-1103

Figure 12-17 Type 7528 Dual Sense Amplifiers With Preamplifier Test Points

12.5.5 Memory Data Register

The memory data register (MDR) is a 16-bit flip-flop register that is used to store a word after it is read out of the memory; or to store a word from the Unibus prior to its being written into the memory. The MDR is composed of eight 74H74 dual high-speed D-type flip-flops: bits D00-D07 are shown in drawing G110-0-1, sheet 3 and are identified as E54, E57, E60, and E63; bits D08-D15 are shown in drawing G110-0-1, sheet 4 and are identified as E42, E45, E48, and E51.

At the start of a memory operation, the MDR is cleared directly via the clear input (pin 1 or pin 13) of each flip-flop: the clear signal is RESET 0 L for bits D00-D07 and RESET 1 L for bits D08-D15.

The operation of the MDR during a read/restore operation (DATI) and a write operation (DATO) is discussed in Paragraph 12.5.1.

12.6 STACK DISCHARGE CIRCUIT

The stack discharge circuit assists the stack capacitance in recovering and shortens the rise time of the stack current. It also reduces unwanted currents in the seven unselected lines associated with the selected driver.

Figure 12-18 shows the stack discharge circuit. Its output is taken from the emitter of transistor Q2 and goes to the junction of each X- and Y-read/write switch pair via a resistor. This common interconnection is labeled V_0 . It is desired that $V_0 \cong 0V$ (ground) during a read operation; and $V_0 \cong -15V$ during a write operation. The effective stack capacitance associated with each line is shown as C_{stack} .

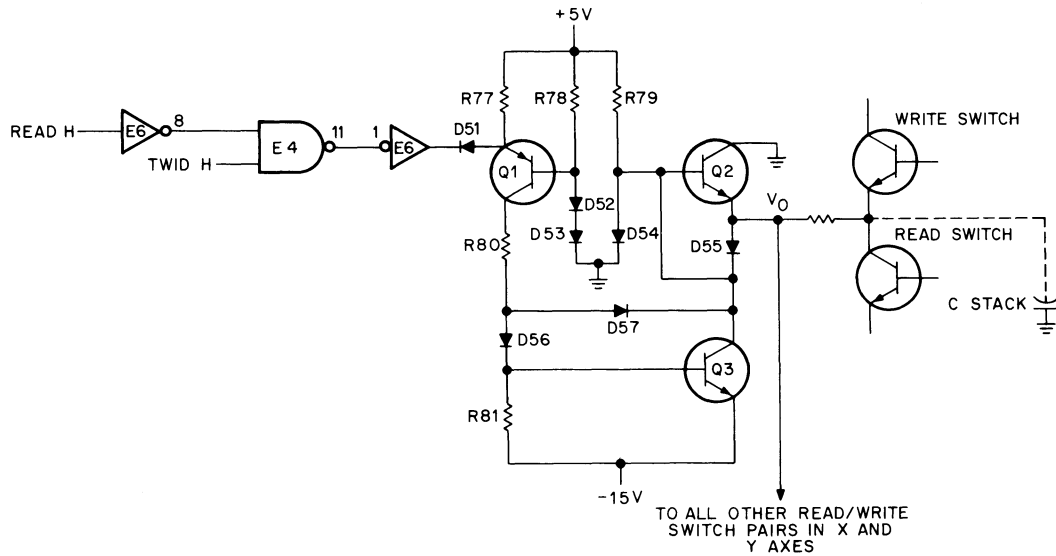

11-1104

Figure 12-18 Stack Discharge Circuit

During a write operation, READ H is low; it is inverted and ANDed with TWID H at NAND gate E4. The low output (pin 11) of E4 is inverted by E6 and sent to the cathode of diode D51, which reverse biases it. The emitter of Q1 becomes more positive, overcomes the constant positive bias, and turns on transistor Q1. When Q1 conducts, it provides base drive for Q3, which also turns on. When Q3 conducts, it reduces the base drive on Q2 and it turns off. The emitter voltage of Q2 goes to approximately $-14V$, which is V_0 on the switch node for the stack. Diode D57 prevents hard saturation of Q3; diode D55 holds Q2 off. During a write operation, $V_0 = -14V$ and the stack discharge circuit is considered to be turned on (input transistor Q1 is on).

During a read operation, READ H is high: it is inverted and ANDed with TWID H at NAND gate E4. The gate is not asserted and its output (pin 11) is high. This signal is inverted by E6 and sent to the cathode of diode D51, which forward biases it. The voltage on the emitter of Q1 produced by the current through R77 and D51 is not enough to overcome the constant positive bias and Q1 is turned off. With Q1 off, Q3 loses its base drive and turns off. Now, D55 cannot hold Q2 off. As long as the stack capacitance is charged negatively, base current exists for Q2 and it remains on. The stack capacitance now charges in the positive direction until it reaches ground potential. During a read operation, $V_0 \cong 0V$ and the stack discharge circuit is considered to be off (input transistor Q1 is off).

Figure 12-13 shows how the stack discharge circuit reduces unwanted currents on the seven unselected lines associated with the selected driver.

During a read operation, the stack discharge circuit is off and $V_0 = 0V$. The current generator drives the read driver node of the stack towards ground; the current generator output is clamped to ground by diode D61. The anodes of the eight read diodes are at ground. The stack discharge circuit is on and the cathodes of the seven unselected diodes are also at ground, which back biases them off. The read switch pulls the cathode of the selected line towards $-14V$, which forward biases it and allows conduction through the diode. Current flows only through the selected line. Reverse biasing of the diodes in the unselected lines prevents current from flowing between the unselected nodes and the selected read driver. The stack discharge circuit performs the same task during the write operation by back biasing the anodes of the diodes in the unselected lines with $-14V$.

12.7 DC LO CIRCUIT

A circuit on the G231 Driver Module (drawing G231-0-1, sheet 2) opens the -15V supply line to the current generators when power is interrupted to the power supply. When power is interrupted, the +5V supply is lost and the operation of all logic is indeterminate. In this state, it is necessary to cut off the -15V supply to the X- and Y-line current generators to prevent them from destroying stored data. The circuit that performs the -15V cutoff is called the DC LO circuit (Figure 12-19).

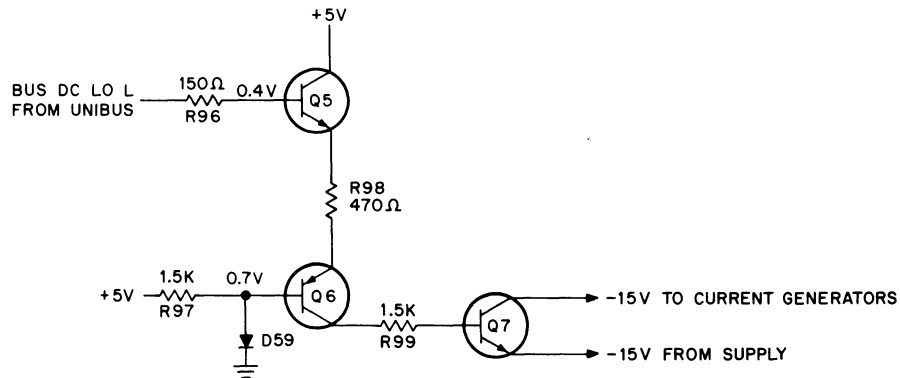

11-1105

Figure 12-19 DC LO Circuit, Schematic Diagram

The -15V supply for the X- and Y-line current generators passes through transistor Q7 in the DC LO circuit. Q7 must be turned on for the -15V to reach the current generators. The circuit monitors BUS DC LO L from the power supply via the Unibus. This signal is sent to the base of transistor Q5. When power is on, BUS DC LO L is high (not asserted).

The voltage across R96 forward biases Q5 and it turns on, which turns on Q6. The conduction through Q5 and Q6 forward biases Q7 which turns it on. The -15V flows through Q7 to the X- and Y-line current generators.

When power is interrupted, BUS DC LO L goes low (asserted). Q5 is now reverse biased and it turns off, which turns off Q6. With Q5 and Q6 off, Q7 is also turned off, which opens the -15V line to the current generators. This circuit still functions when BUS DC LO L is asserted even if the +5V supply drops to zero.

12.8 OPERATING MODE SELECTION LOGIC

When the memory is addressed by the master device, one of four bus transactions is selected. The transaction (or operation) selected is determined by the states of control bits C01 and C00 and address bit A00 as placed on the Unibus by the master device. Table 12-4 shows the states of these bits for each transaction.

The logic that decodes the mode and byte control bits is shown in drawing G110-0-1, sheet 2; it appears at the bottom of the sheet and is identified as the byte masking logic. Bits BUS C01, BUS C00, and BUS A00 are taken from the Unibus to three E29 receivers. One input of each gate associated with C01 and C00 is connected to the output of the PROTECT LOW gate (E29 pin 3). Both inputs to this gate are tied to +5V so that its output is always low. For troubleshooting purposes, a jumper (W11) can be installed that makes the gate output high, which allows only DATI operations to be performed regardless of the states of bits C01 and C00. This jumper hardwires the memory as a read-only device.

**Table 12-4
Selection of Bus Transactions**

Transaction	Mnemonic	Mode Control		Byte Control A00	Function
		C (01:00)	Octal		
Data In	DATI	00	0	X	Data from memory to master. Memory performs operations.
Data In, Pause	DATIP	01	1	X	Data from memory to master. Restore operation is inhibited. Must be followed by DATO or DATOB: Read operation is inhibited.
Data Out	DATO	10	2	X	Data from master to memory (words).
Data Out, High Byte	DATOB	11	3	1	Data from master to memory. High byte on data lines D (15:08).
Data Out, Low Byte	DATOB	11	3	0	Data from master to memory. Low byte on data lines D (07:00).

The outputs of the three E29 receivers (C01, C00, and A00) are sent to the byte masking logic to generate LOAD 0 H and LOAD 1 H and to qualify a group of gates, which are enabled by control signals to generate RESET 0 L, RESET 1 L, STROBE 0 H, STROBE 1 H, and DATA OUT H. The logic also conditions the D-input of the PAUSE flip-flop (E4, pin 12) to allow it to be set or reset. It also applies conditioning signals to the wired-AND that provides the clocking signal to the slave synchronization (SSYN) flip-flop. The PAUSE flip-flop and the SSYN flip-flop are part of the control logic.

The signals generated for each bus transaction are shown in Table 12-5. The memory operational sequences are discussed in subsequent paragraphs. To avoid confusion in interpreting the transactions listed in Table 12-5, the purpose of the PAUSE flip-flop is discussed briefly. During DATIP, the PAUSE flip-flop is set during the read operation, which inhibits the restore (write) operation. The DATIP must be followed by a DATO or DATOB on the same address. The DATO or DATOB that follows a DATIP is shorter than a standard DATO or DATOB because the initial read operation is eliminated. In Table 12-5, the suffix PAUSE L identifies the standard transactions; the suffix PAUSE H identifies the DATO and DATOB transactions that must follow a DATIP.

12.9 CONTROL LOGIC

The control logic generates the precisely timed signals that initiate and stop the memory operations that are requested as a result of the decoding of the bus transaction. The heart of the control logic is the delay line timing circuit. For better understanding, the timing circuit, slave sync circuit, pause/write restart circuit, and strobe generating circuit are described separately. Each bus transaction is also discussed in detail. The discussion is to the detailed logic level but the signals are not traced through each component. The text is referenced to logic drawing G110-0-1, sheet 2 and the timing diagrams in drawing MM11-L-3.

Table 12-5
Generation of Memory Operating Signals

Mode	Byte Control A00	Mode Control		State of PAUSE Flip-Flop	Signals Generated							Operation Sequence
		C01	C00		STROBE 0	STROBE 1	RESET 0	RESET 1	LOAD 0	LOAD 1	DATA OUT H	
DATI	X	0	0	Reset	X	X	X	X			X	Read-Restore.
DATIP	X	0	1	Reset-Set	X	X	X	X			X	Read-Pause. Restore inhibited by PAUSE flip-flop.
DATO PAUSE L	X	1	0	Reset					X	X		Clear-Write.
DATO	X	1	0	Set					X	X		Write. Must follow DATIP.
DATOB PAUSE L	0	1	1	Reset		X		X	X			Clear-Write selected byte 0. Clear-Restore non-selected byte 1.
DATOB PAUSE H	0	1	1	Set		X		X	X			Write selected byte 0. Restore non-selected byte 1. Must follow DATIP.
DATOB PAUSE L	1	1	1	Reset	X		X			X		Clear-Write selected byte 1. Clear-restore non-selected byte 0.
DATOB PAUSE H	1	1	1	Set	X		X			X		Write selected byte 1. Restore non-selected byte 0. Must follow DATIP.

12.9.1 Timing Circuit

The heart of the memory control logic is the timing circuit. When activated, it generates a series of precisely timed signals that control memory operation. The major component of the timing circuit is a delay line (DL1) with multiple 25-ns taps (drawing C110-0-1, sheet 2). The delay line outputs are gated to produce the control signals. Figure 12-20 shows the timing of the delay line outputs and the timing of the control signals obtained by gating these outputs. A brief statement of the function of each control signal is included. Absolute timing is obtained from the engineering timing diagram (drawing MM11-L-3). The discussion is referenced to Figure 12-20 and the control logic drawing G110-0-1.

When the system is turned on, the processor asserts BUS INIT L on the Unibus. This initializing signal is sent to pins 6 and 7 of bus receiver E7. It is inverted by E7 to produce a high, which is sent to pins 9 and 10 of the memory select reset (MSEL RESET) gate E16. The output (pin 8) of E16 is low and is used to clear (reset) MSEL flip-flop E2 via the 100-ns delay DL3. The output of E7 is also inverted by E18 to provide a low that clears read/write (R/W) flip-flop E3. The output of E7 is also inverted by E15 to provide a low that clears PAUSE flip-flop E4. The low

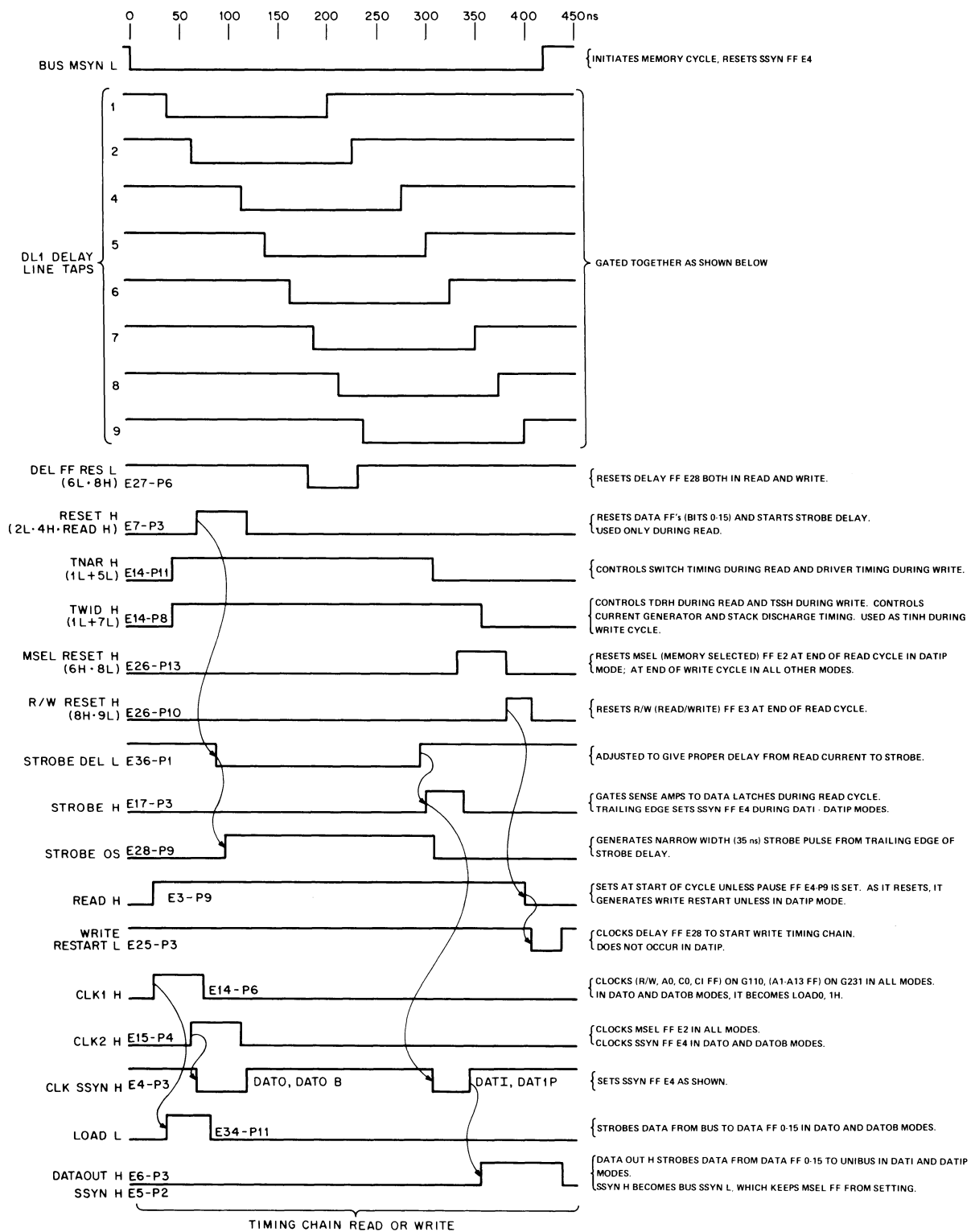

11-1108

Figure 12-20 Basic Timing and Control Signal Functions

output of E15 is double inverted by two E38 gates to clear the DEL flip-flop E28. The master places the address, mode control state, and data (if required) on the Unibus. The device address is decoded and DSEL H is generated and sent to pin 13 of E1, which is one of four input signals (pins 10, 11, 12, and 13). Pin 11 is high via the 0-output of MSEL flip-flop E2. SSSYN flip-flop E4 is preset, making pin 10 of E1 high via its 1-output (pin 5). When the master asserts BUS MSYN L to bus receiver E23, pin 12 of E1 is high also. The output of E1 (pin 8) goes low and is sent to pin 13 of E5, pins 4 and 5 of E14, and pin 1 of delay line DL2. E14 inverts the low from E1 to start the positive CLK 1 H pulse. DL2 provides a 30-ns delay for the low signal from E1, which is inverted by E15 to start the positive CLK 2 H pulse. The output (pin 3) of DL2 is also sent to the preset input (pin 4) of MSEL flip-flop E2, and pin 6 goes low which in turn is fed back to pin 10 of E1 to disable it. The output (pin 8) of E1 is now high, and this signal terminates both clock pulses (CLK 1 H and CLK 2 H) via gates E14 and E15. These pulses are approximately 50-ns wide.

Gate E5 also inverts the low from E1 because pin 12 (WRITE RESTART L) of E5 is high. The positive transition at the output (pin 11) of E5 clocks delay (DEL) flip-flop E28 which sets it. Pin 5 of E28 is high and is connected to pins 1 and 2 of DL1 driver gate E34. The low from the E34 output (pin 3) is the input to delay line DL1. This signal remains low for approximately 225 ns until DEL flip-flop E28 is cleared by DELAY FF RESET L. This provides a negative pulse that propagates through the delay line and can be picked off at 25-ns intervals.

DL1 taps 2, 4, 5, 6, 7, 8, and 9 are used to generate control signals. Figure 12-20 depicts each control signal and relates it to logic drawing G110-0-1, sheet 2.

DELAY FF RESET

Tap 6L is inverted by E15 and sent to pins 3 and 5 of 3-input NAND gate E27; the third input (pin 4) is tap 8H. The output (pin 6) of E27 clears the DEL flip-flop E28; however, it is ORed with INIT L in gate E28 (pins 9 and 10) and inverted by E38, pin 11 so that either (6L . 8H) or BUS INIT L can produce DELAY FF RESET L, which clears E28 via its clear input (pin 1). This signal is generated in both read and write operations.

RESET H

Tap 2L, tap 4H, and signal READ H are gated to generate RESET H, which triggers the strobe delay circuit and generates RESET 0 L and RESET 1 L during the read operation only. Tap 4H and READ H (high during read operation) are ANDed at pins 10 and 9 of E17. The low output of E17 is ANDed with tap 2L in gate E7. The high output (pin 3) is RESET H.

TWID H and TNAR H

The 0-output of DEL flip-flop E28 is ORed with tap 5L and tap 7L in separate gates (E14) to produce signals TWID H and TNAR H. Tap 5L is sent to pin 13 of E14; the other input to this gate (pin 12) is from the 0-output of DEL flip-flop E28. Tap 7L is sent to pin 10 of another E14 gate; pin 9 of this gate is also connected to the 0-output of DEL flip-flop E28. These gates are 2-input NAND gates (type 7437); however, they are shown as logically equivalent negative-input OR gates, because it is desired to have them asserted high (logical 1) when TWID H or TNAR H is asserted.

At the start of a read or write cycle, just before E28 is set, TNAR and TWID are low because both inputs to each gate are high. E28 is set and pins 12 and 9 of E14 go low; TNAR and TWID are both high, which starts the positive TNAR and TWID pulses simultaneously. When taps 5 and 7 go low (E28 is still set), TNAR and TWID remain high. At the end of the read or write cycle, E28 is cleared (taps 5 and 7 are still low) and TNAR and TWID still remain high. When tap 5 is high again, TNAR goes low because both inputs (pins 12 and 13) of E14 are high. This terminates the positive TNAR pulse. Approximately 50-ns later, tap 7 is high again and TWID goes low, terminating the positive TWID pulse. In summary, TNAR H and TWID H are started together by setting DEL flip-flop E28 before taps 5 and 7 are low; TNAR H and TWID H are not effected when taps 5 and 7 go low. Signals TNAR H and TWID H are terminated when taps 5 and 7 return high. The intervening clearing of E28 does not affect TNAR H or TWID H.

Signals TNAR H and TWID H provide various control functions related to the operation of the switches, drivers, current generators, inhibit drivers, and stack discharge circuit. At this point, the discussion digresses to follow TNAR H and TWID H through some additional logic in order to understand their functions. The logic is spread throughout several engineering drawings. To simplify the discussion, all the logic is shown in Figure 12-21.

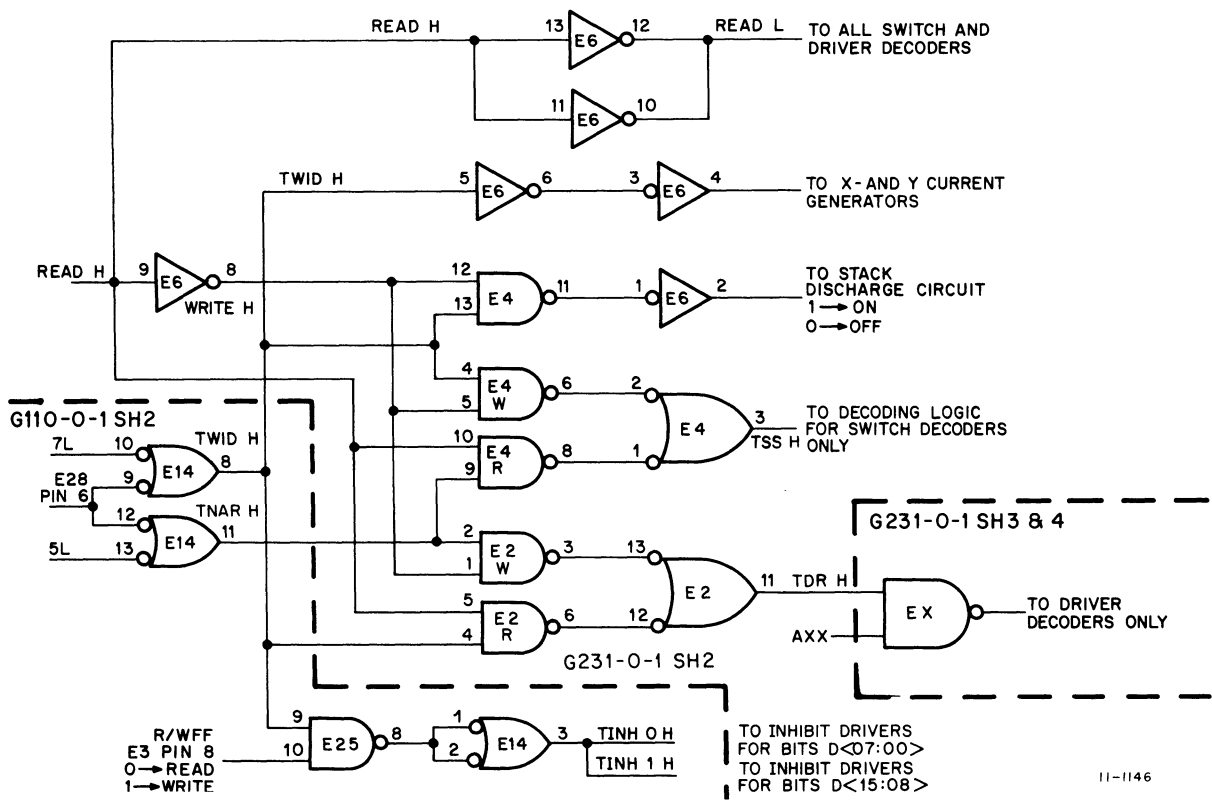

Figure 12-21 TWID H and TNAR H Control Logic

Signal TWID H is ANDed with the 0-output (pin 8) of R/W flip-flop E3 at pins 9 and 10 of gate E25. With TWID H high, E25 is asserted only when E3, pin 8 is high; this occurs only during a write operation. The output (pin 8) of E25 is inverted by E14 to procure TINH 0 H and TINH 1 H. The output of E14 is physically divided into two paths: TINH 0 H activates the inhibit drivers for bits D (07:00), and TINH 1 H activates the inhibit drivers for bits D (15:08). These signals do not leave the control module because the inhibit drivers are also on this module.

Signals TWID H and TNAR H leave the control module (G110) and are sent to the drive module (G231). TWID H is sent to pin-4 of E2R, and TNAR H is sent to pin 2 of E2W. Gates E2 and E4 are marked W and R in Figure 12-21 to show their association with write or read operations. READ H is sent from the 1-output (pin 9) of R/W flip-flop E3 on the control module to pin 9 of inverter E6 on the driver module. READ H is high during a read operation and low during a write operation. Assume that a read operation is selected. READ H is high at pin 9 of E6 and is sent to pin 5 of E2R to be ANDed with TWID H. This gate is asserted and its low output is sent to pin 12 of negative-input NOR gate E2, which inverts it to produce TDR H. This signal is a decoding input for the memory read/write drivers only. Gate E2W is not asserted because WRITE H, which is the inversion of READ H, is low. Therefore, TWID H controls decoding signal TDR H during a read operation. During a write operation, READ H is low and WRITE H is high. Signal TDR H is asserted via the output of gate E2W, using the ANDing of WRITE H and TNAR H. Decoding signal TDR H is controlled by TNAR H during a write operation.

A similar logic network is used to control signal TSS H, which enables six decoding signals that are in turn used to control memory read/write switches only. When gates E4W, E4R, and E4 are used, TSS H is generated at the output (pin 3) of E4. During a read operation, TNAR H controls enabling signal TSS H; signal TWID H controls TSS H during a write operation.

TWID H controls the operation of the X- and Y-current generators. During read and write operations, when TWID H is high, the signal is double inverted by two E6 inverters to turn both current generators on.

The TWID H signal also controls the operation of the stack discharge circuit. It is ANDed with WRITE H at pins 13 and 12 of NAND gate E4. The output (pin 11) of E4 is inverted by E6 to control the stack discharge circuit. This circuit is considered to be turned on when the output (pin 2) of E6 is high. This occurs during a write operation when TWID H and WRITE H are both high.

Although not part of the timing circuit, Figure 12-21 shows READ H inverted by two E6 inverters to become READ L, which is a decoding input to all 8251 decoders for the memory switches and drivers. During a read operation, READ H is high and READ L is low, which selects only read switches and drivers; conversely, during a write operation, READ L is high, which selects only write switches and drivers (Paragraph 12.4.3.2).

MSEL RESET

The memory select (MSEL) flip-flop E2 is cleared (reset) at the end of a read operation in DATIP mode and at the end of a write operation in all other modes (DATI, DATO, and DATOB) by signal MSEL RESET L. The MSEL RESET L signal is generated at the output (pin 8) of gate E16 (a type 74H53 2-2-2-3 input AND-OR-invert gate). Three of its four AND inputs are used to facilitate the various methods used in generating MSEL RESET L (Figure 12-22).

When the system is turned on, the processor asserts BUS INIT L on the Unibus. The output of bus receiver E7 is high; this high output is sent to pins 9 and 10 of E16 to generate MSEL RESET L at its output (pin 8). The MSEL RESET L signal is passed through a 100-ns delay line (DL3) to the clear input (pin 1) of MSEL flip-flop E2, which directly clears (resets) it. All memory operations start with E2 cleared; however, this flip-flop is set approximately 75 ns after the processor asserts BUS MSYN L. It remains set until it is cleared by one of the following operations.

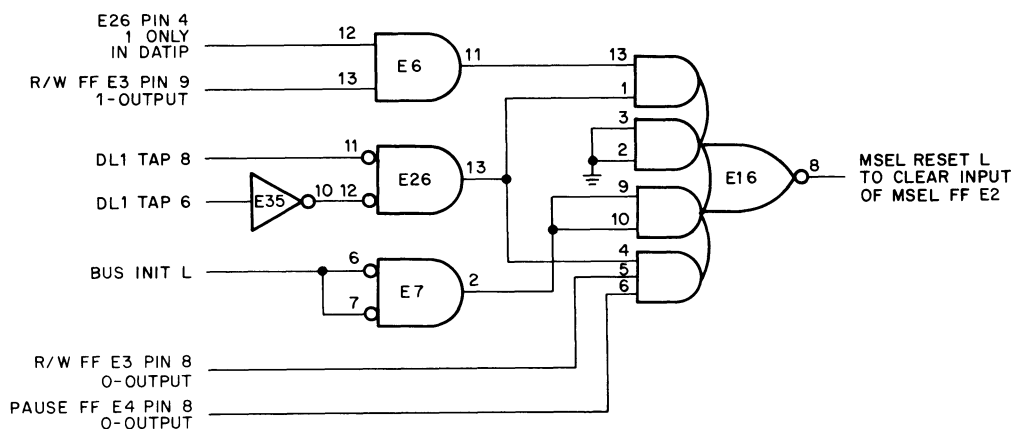

11-1145

Figure 12-22 Generation of MSEL RESET L

In the DATIP mode, pin 12 of AND gate E6 is high; in all other modes, it is low, disqualifying E6. A read operation is performed in DATIP, and R/W flip-flop E3 is set. The 1-output of E3 is sent to pin 13 of E6. At this time, pin 13 is high and a high is generated at the output (pin 11) of E6. This AND input is qualified when pin 1 is also high, which occurs when DL1 tap 6 is high and DL1 tap 8 is low. Tap 6H is inverted by E35 and sent to pin 12 of E26. Tap 8L is sent directly to the other input (pin 11) and the gate is asserted; this gate sends a high to pin 1 of E16, which generates MSEL RESET L at the output (pin 8) of E16. This low signal clears MSEL flip-flop E2 at the end of the read operation (timed by 6H and 8L).

In all other modes (DATI, DATO, and DATOB), signal MSEL RESET L is generated at the end of the write operation (except DATO or DATOB following a DATIP). The R/W flip-flop is set, making its 0-output (pin 8) low, which disqualifies the 3-input (pin 4, 5, and 6) AND gate in E16.

Taps 6H and 8L cannot qualify this AND input or the other AND input (pins 1 and 13) because the memory is not in the DATIP mode. Therefore, the read operation is completed and MSEL RESET L is not generated. The write operation is now started and the R/W flip-flop is cleared, which puts a high on input 5 of E16. Input 6 is high because the PAUSE flip-flop is reset (pin 8 is a 1). Now, when tap 6 is high and tap 8 is low, input 4 of E16 is high. This generates signal MSEL RESET L to clear MSEL flip-flop E2 at the end of the write operation. This circuit performs the function of a memory bus flip-flop.

R/W RESET

The timing for the generation of the signal to clear (reset) R/W flip-flop E3 is obtained from taps 8 and 9 of DL1. Tap 9 is sent directly to pin 8 of E26. Tap 8 is inverted by E35 and sent to pin 9 of E26. When tap 9 is low and tap 8 is high, E26 is asserted (output pin 10 is high). This signal is sometimes called R/W RESET H. It is ANDed with READ H at pins 2 and 1 of NAND gate E18 to generate R/W RESET L. When this signal is a low, it directly resets R/W flip-flop E3 via its clear input (pin 13). READ H is high when the R/W flip-flop is set because it comes from the 1-output (pin 9). The remainder of the control signals shown in Figure 12-20 are discussed in the circuit descriptions contained in Paragraph 12.9.2, Slave Synchronization Circuit; Paragraph 12.9.3, Pause/Write Restart Circuit; and Paragraph 12.9.4, Strobe Generating Circuit.

12.9.2 Slave Synchronization (SSYN) Circuit

Slave synchronization (SSYN) is the response of the slave device to the master, usually a response to master synchronization (MSYN). The master places address information, mode control information, and data (if a DATO or DATOB is selected) on the Unibus. It then asserts BUS MSYN L but only if BUS SSYN L from the slave is cleared, which indicates that the slave can participate in a bus transaction. The slave asserts BUS SSYN L when it has data to send (DATI or DATIP) or when it has received data (DATO or DATOB). The master receives BUS SSYN L in both cases and clears BUS MSYN L. When the slave receives the cleared BUS MSYN L, it clears BUS SSYN L which frees the bus. This brief statement of the SSYN/MSYN interaction is necessary to understand the operation of the memory SSYN circuit. Details of the SSYN/MSYN interaction during all bus transactions can be found in the *PDP-11 Peripherals and Interfacing Handbook*. The SSYN circuit is shown in drawing G110-0-1, sheet 2; however, for clarity, only the SSYN circuit is shown in Figure 12-23 along with appropriate timing diagrams.

During a DATI or DATIP transaction, signal BUS SSYN L is asserted by the memory when the data is placed on the Unibus by the MDR. During a DATO or DATOB transaction, BUS SSYN L is asserted by the memory when it receives data from the Unibus.

At the start of each transaction, the master first places the memory address (device and word) and mode control information on the Unibus. (Data is included if the transaction is DATO or DATOB.) For a DATI or DATIP transaction, BUS C01 L is high at pin 10 of bus receiver E29. The output (pin 14) of E29 is low and is sent to the D-input (pin 6) of C01 latch E30 and to pin 5 of the E5 WRITE gate. Signal BUS MSYN L has not yet been asserted; thus, the output (pin 13) of bus receiver E23 is low. This signal is sent to pin 2 of NOR gate E26: the other input (pin 3) of this gate is always low because MSYN A L is normally not connected. The output (pin 1) of E26 is inverted by E15 to produce SSYN RESET L; this signal sets SSYN flip-flop E4 via its preset input (pin 4). The low 0-output (pin 6) is sent to both inputs of bus driver E5. The output of this gate is the slave synchronization signal (BUS SSYN L) and, at this point, it is not asserted.

As long as BUS MSYN L is not asserted, the SSYN flip-flop is preset. The master now asserts BUS MSYN L, which in turn disables the preset signal to the SSYN flip-flop (SSYN RESET L is high). Clock signal CLK 1 H is generated and clocks C01 latch E30. Latch E30 is reset and its high 0-output (pin 11) is sent to pin 10 of the E5 READ gate in the wired-AND. The wired-AND output CLK SSYN is high, and it remains high as long as both E5 NAND gate outputs are high; this occurs when at least one input of each gate is low. The output of E5 WRITE remains high because input pin 5 is held low by the output of C01 receiver E29. The output of this gate is not changed when the CLK 2 H pulse appears at pin 4. The output of E5 READ remains high until STROBE H goes low again; the wired-AND output is high again. This positive transition clocks the SSYN flip-flop, which now resets because its D-input is tied to ground (low). The high 0-output (pin 6) of the SSYN flip-flop asserts BUS SSYN L at the output (pin 3) of bus driver E5. The master receives the asserted BUS SSYN L signal and clears BUS MSYN L. The memory receives the cleared BUS MSYN L from the master at bus receiver E23 and generates signal SSYN RESET L via gates E26 and E15 to set the SSYN flip-flop. The memory is now ready for the next transaction.

For a DATO or DATOB, the sequence is the same except that BUS C01 L is low at pin 10 of bus receiver E29. This conditions the wired-AND so that the output of E5 READ remains high. In this case, the CLK 2 H pulse generates the CLK SSYN pulse that clocks the SSYN flip-flop via E5 WRITE.

12.9.3 Pause/Write Restart Circuit

The PAUSE flip-flop is used to inhibit the restore (write) operation during a DATIP transaction. This transaction is useful when there is no need to restore data after reading because the location is to have new data written into it. By eliminating the restore operation, memory cycle time is decreased by approximately 50 percent. A DATIP must always be followed by a DATO or DATOB. In this case, the DATO or DATOB is shortened by eliminating the clear (read) operation that is normally performed prior to the restore (write) operation. The location has been cleared previously by the DATIP; consequently, the DATO or DATOB need only perform the restore (write) operation. The pause/write restart circuit is shown in drawing G110-0-1, sheet 2; however, for clarity, only the pause/write restart circuit is shown in Figure 12-24.

At the start of all bus transactions, the PAUSE flip-flop is reset; it remains reset throughout the bus transactions except during a DATIP, in which case it is set during the read operation. The PAUSE flip-flop is clocked by the reset 0-output (pin 6) of the SSYN flip-flop. The state (set or reset) of the PAUSE flip-flop is determined by its D-input (pin 12): the D-input is high to set and low to reset. The state of the D-input is controlled by Unibus mode control bits C01 and C00. (Only the mode control representing a DATIP provides a high to the D-input of the PAUSE flip-flop.) During a DATIP, C01 is high and C00 is low at bus receivers E29, pin 10 and E29, pin 7. These signals are inverted by the bus receivers and applied to the D-input of the C01 and C00 latches: C00 latch E30, pin 3 is high, and C01 latch E30, pin 6 is low. When the latches are clocked by the CLK 1 H signal, latch C01 is reset and C00 is set. This action puts a low on each input of negative input AND gate E26, which generates a high output. This high output is the D-input to the PAUSE flip-flop. The PAUSE flip-flop is now conditioned to set when it is clocked.

Returning to the start of the DATIP operation, the PAUSE flip-flop is reset. Its D-input is conditioned (D is high) but the PAUSE flip-flop has not been clocked; thus, its 0-output (pin 8) is high. This high output goes to the D-input of the Read/Write flip-flop (R/W E3); this flip-flop is clocked early in the sequence by CLK 1 H. The R/W flip-flop is then set which permits a read operation. The low 0-output (pin 8) of the R/W flip-flop is sent to pin 4 of E17. The other input (pin 5) of E17 comes from the 0-output (pin 8) of the PAUSE flip-flop, and it is a high at this time. The output of E17 is a high and is inverted by E15, which puts a low on the clear input of the Write Restart flip-flop (WRRS E2). The output of E15 also goes to input 2 of E25. The WRRS flip-flop is cleared (reset) and its high 0-output (pin 8) is sent to the other input (pin 1) of E25. The output of E25 is the WRITE RESTART L signal. This signal is produced to trigger the timing circuit and to initiate a write operation. Signal WRITE RESTART L is now high, its proper state when a read operation is being performed.

At the end of the read operation, the SSYN flip-flop is clocked which resets it. The positive transition at its 0-output (pin 6) clocks the PAUSE flip-flop, which sets the SSYN flip-flop and puts a low on pin 5 of E17. The timing circuit clears (resets) the R/W flip-flop, which in turn puts a high on pin 4 of E17. The output of E17 remains high, inhibiting the WRITE RESTART L signal and preventing the initiation of a write operation.

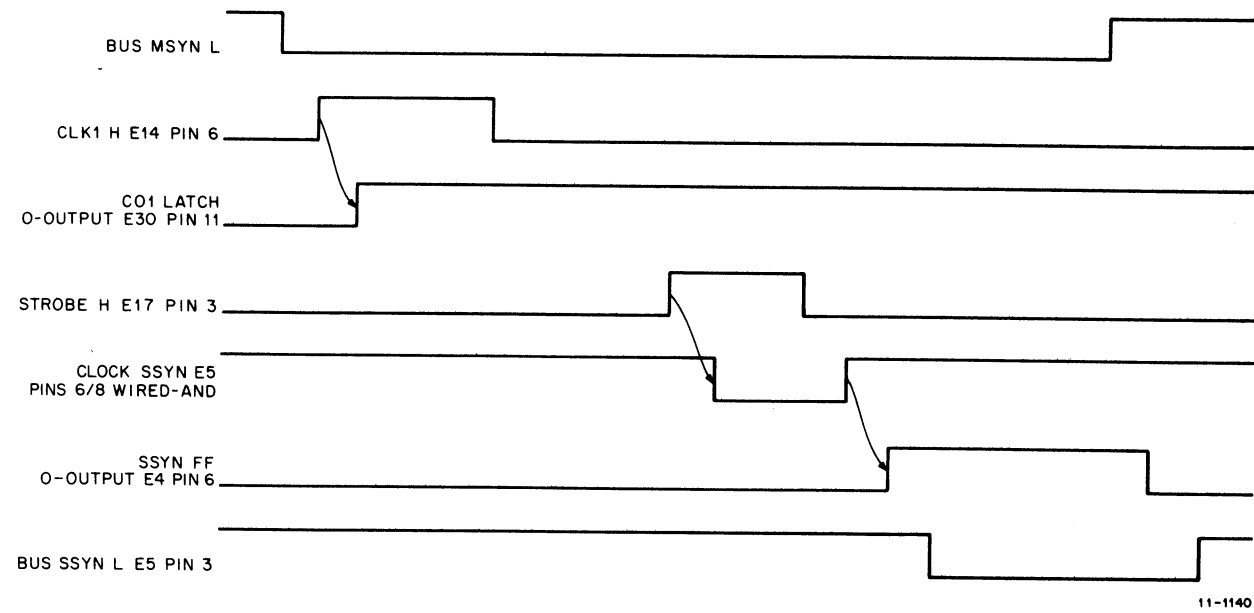

Timing Diagram for SSYN Circuit During DATI and DATIP

11-1140

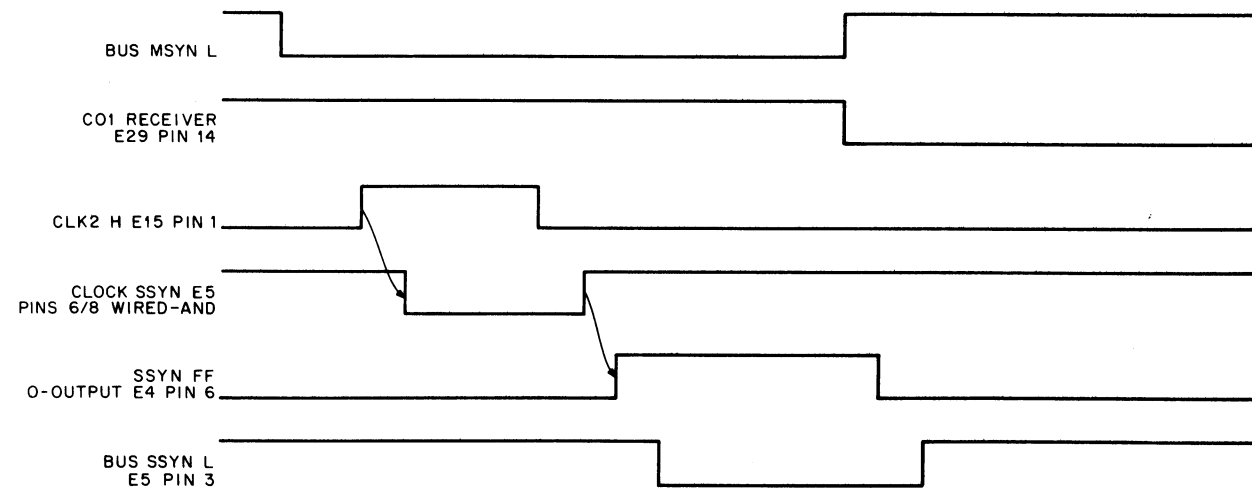

Timing Diagram for SSYN Circuit During DATO and DATOB

11-1141

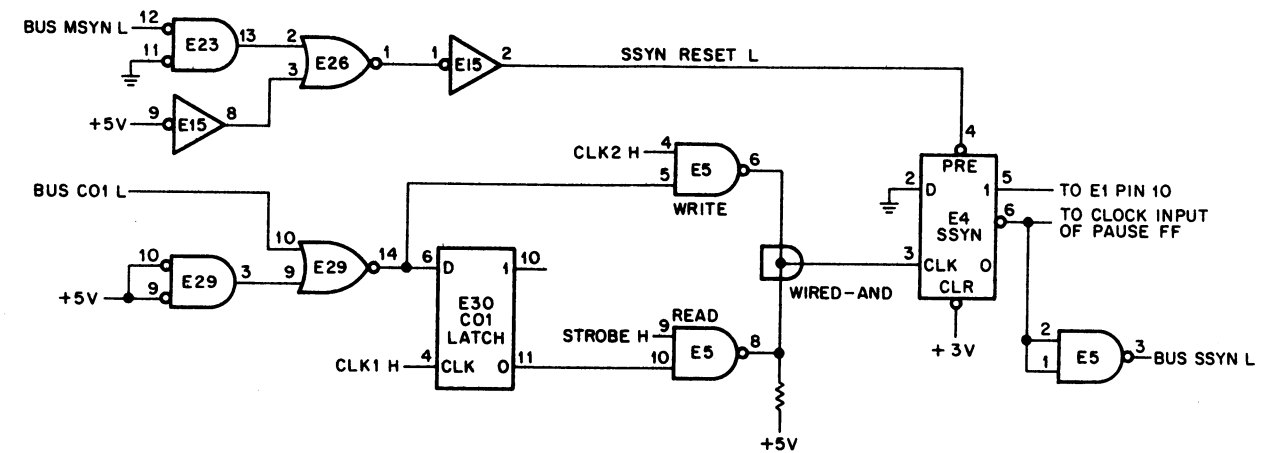

11-1139

Figure 12-23 Slave Sync (SSYN) Circuit

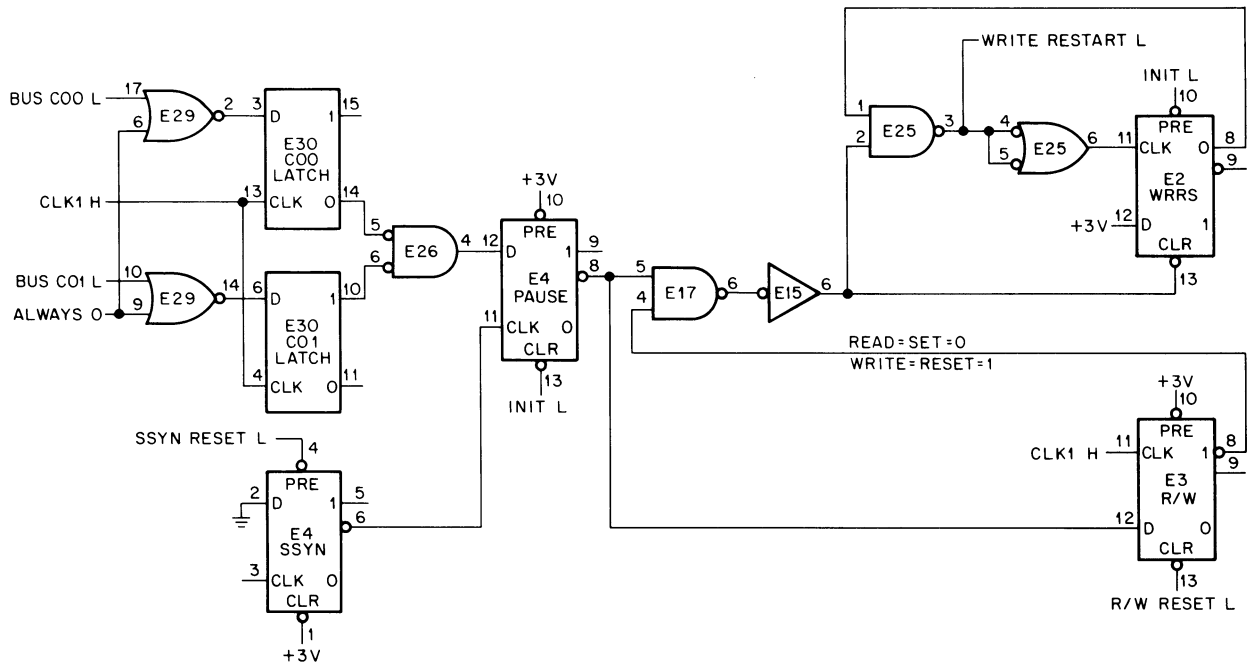

11-1144

Figure 12-24 Pause/Write Restart Circuit

For any transaction other than DATIP (DATI, DATO, or DATOB), the PAUSE flip-flop is not set when it is clocked because its D-input is low. It remains reset which keeps a high on pin 5 of E17.

When the R/W flip-flop is cleared, it puts a high on pin 4 of E17. The low output of E17 is now inverted by E15 and sent to pin 2 of E25. The WRRS flip-flop is reset so that pin 1 of E25 is also high. The output (pin 3) of E25 goes low, which generates WRITE RESTART L. This starts the formation of a low WRITE RESTART L pulse. This output is inverted by E25, pin 6 which clocks the WRRS flip-flop and sets it, because its D-input is connected to +3V. Pin 8 of the WRRS flip-flop now goes low, which is in turn fed to pin 1 of E25. Thus, the output of E25 becomes high again, which terminates the low WRITE RESTART L pulse. This pulse triggers the timing circuit and initiates a write operation.

For a DATO or DATOB following a DATIP, the PAUSE flip-flop is reset by the SSYN flip-flop, because the DATO or DATOB transaction started with the PAUSE flip-flop set previously by the DATIP.

12.9.4 Strobe Generating Circuit

The strobe generating circuit produces a narrow positive pulse (STROBE H) during the read operation to enable the STROBE 0 H and STROBE 1 H signals for the sense amplifiers. The strobe generating circuit is shown in drawing G110-0-1, sheet 2; however, for clarity, only the strobe generating circuit is shown in Figure 12-25 along with an appropriate timing diagram.

During the read operation, the timing circuit generates a positive RESET H pulse. The RESET H pulse is sent to pin 5 of the strobe delay one-shot (ST DEL E36); this 74121 one-shot provides complementary outputs but only the Q (negative pulse) output (pin 1) is used. Pins 3 and 4 of the ST DEL one-shot are connected to ground so that it can be triggered by a positive-going edge at pin 5. Prior to receiving the triggering signal (RESET H), the strobe generating circuit is in the quiescent state. The STROBE OS flip-flop E28 is in the reset state. (When the memory is

powered up, E28 is driven to the reset state by E36 if it did not come up reset randomly.) The low 1-output (pin 9) of E28 is sent to pin 13 of E17. The ST DEL one-shot is inhibited so that its \bar{Q} output (pin 1) is high, which is sent to pin 12 of E17. The output (pin 11) of E17 is high and is inverted by the next E17 gate (pin 3). This is the STROBE H signal, and it is low at this time.

The timing circuit generates a positive RESET H pulse that is sent to pin 5 of E36. The positive edge of RESET H triggers E36, and its \bar{Q} output (pin 1) goes to low. This is the start of a single negative pulse whose duration is determined by an external RC circuit connected to pins 10 and 11 of E36. The output of E36 directly sets STROBE E OS flip-flop E28 via its preset input (pin 10). The 1-output (pin 9) of E28 goes high and is sent to pin 13 of E17. The other input to this gate (pin 12) is now low. E17, pin 11 is high and is inverted so that E17, pin 3 is still low (no strobe pulse yet). When E36 times out, its output (pin 1) goes high again. Pins 12 and 13 of E17 are now both high, and the output (pin 11) of E17 is low. This signal is inverted and E17, pin 3 is high. This is the beginning of the STROBE H pulse. The positive transition of E17, pin 3 also clocks flip-flop E28. E28 is reset because its D-input is connected to ground (low); pin 9 of E28 is now low. It is fed back to pin 13 of E17, which makes E17, pin 3 low again. This terminates the positive STROBE H pulse. The circuit is back to its quiescent state where it remains until another RESET H pulse comes along to trigger ST DEL one-shot E36.

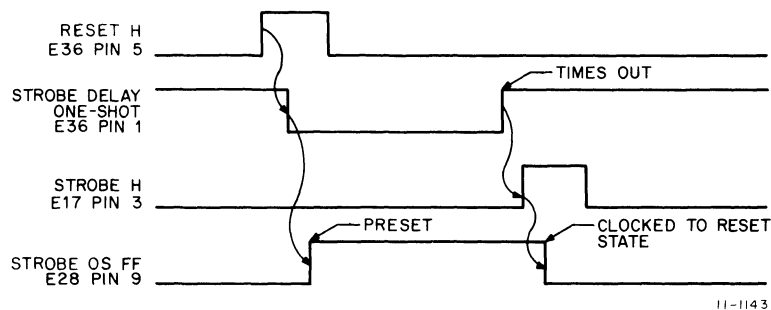
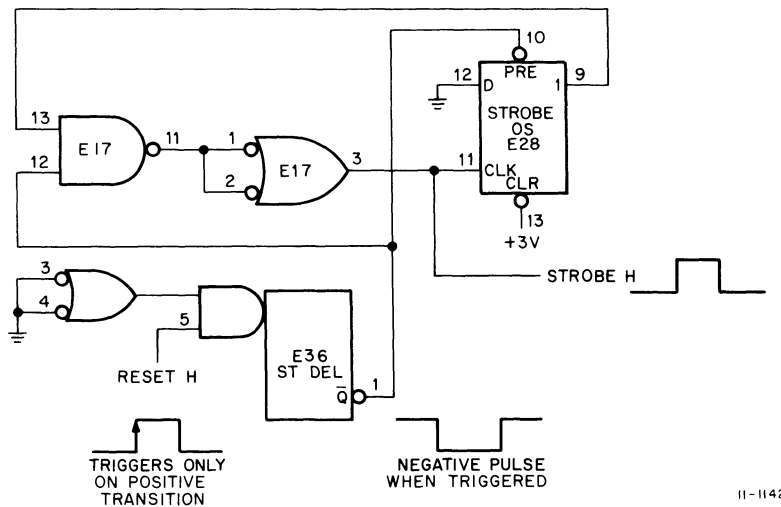

Figure 12-25 Strobe Generating Circuit and Timing Diagram for STROBE H

12.9.5 Data In (DATI) Operation

In the discussion of the DATI operation (as well as the DATIP, DATO, and DATOB operations) signals are not traced through circuit components; rather, various events are integrated to describe a complete memory operating cycle. All the circuits involved have been discussed in detail in the preceding paragraphs of this chapter. Refer to engineering logic drawings G110-0-1, sheets 2, 3, and 4; G231-0-1, sheets 2, 3, and 4; MM11-L-3 (timing diagram); and Figure 12-26, which is a flow chart for memory operation.

In a DATI operation, the master requests that a selected memory location be read and the information transferred to the master via the Unibus. The readout is destructive because the read operation forces all cores in the selected location to 0. However, during readout, the information is temporarily stored in the MDR and is automatically restored to the selected location by a write operation that immediately follows the read operation.

At the start of the DATI, MSEL flip-flop is reset, DEL flip-flop is reset, R/W flip-flop is reset, PAUSE flip-flop is reset, and SSYN flip-flop is set. The address lines and mode control lines (C01 and C00) are decoded. The master asserts the BUS MSYN L signal and the cycle begins. Signal CLK 1 H is generated, the DEL flip-flop is set, and the R/W flip-flop is set. Setting the DEL flip-flop initiates the timing chain via delay line DL1. The timing chain generates TWID H and TNAR H. At the same time, CLK 2 H is generated and it presets the MSEL flip-flop, which prevents the start of another cycle until it is reset. Signal READ H from the R/W flip-flop and signals TNAR H and TWID H go to the driver module to select the appropriate read drivers and switches, turn on the X- and Y-current generators, and control the stack discharge circuit. As a result of these signals, the X- and Y-half currents are directed to the selected memory location, and all 16 cores (one per bit plane) are set to 0. Just prior to this event, the timing chain generates RESET 0 L and RESET 1 L; these signals clear the MDR. The timing chain then generates STROBE H, which asserts STROBE 0 H and STROBE 1 H; these signals are sent to the sense amplifiers. The strobe pulses are timed to arrive at the same time as the pulses induced in the sense/inhibit line. If a selected core is a 1, a pulse is induced in the sense/inhibit line that exceeds the sense amplifier threshold and produces an amplified positive pulse. This output is inverted and presets its associated MDR flip-flop and a 1 is stored in the flip-flop. Signal STROBE H also clocks the SSYN flip-flop which resets. The SSYN flip-flop output asserts DATA OUT H and BUS SSYN L. Signal DATA OUT H gates the output of the MDR to the Unibus. BUS SSYN L is a Unibus signal that informs the master that the memory has read the selected location and placed the data on the Unibus. The master takes the data and clears BUS MSYN L, which in turn generates SSYN RESET L to set the SSYN flip-flop. BUS SSYN L is cleared to indicate that the Unibus is free; however, another bus transaction cannot be initiated even if the master asserts BUS MSYN L because the lockout feature of the MSEL flip-flop is still set. Prior to the assertion of BUS SSYN L, the timing chain generates DELAY FF RESET L, which resets the DEL flip-flop and allows the TNAR H and TWID H pulses to terminate as a function of taps 5 and 7 of the delay line. The timing chain also generates R/W RESET L, which resets the R/W flip-flop.

The memory now enters the write (or restore) cycle. With the R/W flip-flop and PAUSE flip-flop both reset, the pause/write restart circuit generates the WRITE RESTART L signal, which initiates another timing cycle by setting the DEL flip-flop.

The timing chain generates TWID H and TNAR H. These signals, plus a low READ H signal from the R/W flip-flop, go to the driver module to select the appropriate write drivers and switches; turn on the X- and Y-current generators; and control the stack discharge circuit. In addition, TWID H and an output from the R/W flip-flop are ANDed to generate TINH 0 H and TINH 1 H. These signals control the operation of the inhibit drivers. Signals TINH 0 H and TINH 1 H are ANDed with the outputs of the MDR flip-flops. If a 1 is stored in the MDR flip-flop, the associated inhibit driver is not turned on and a 1 is written into this bit of the selected memory location. If a 0 is stored in the MDR flip-flop, the associated inhibit driver is turned on and produces a current that opposes the Y-line current and prevents a 1 from being written into this bit. The timing chain generates DELAY FF RESET L, which resets the DEL flip-flop and allows TNAR H, TWID H, and the inhibit pulses (TINH 0 H and TINH 1 H) to terminate. The timing chain also generates MSEL RESET L, which resets the MSEL flip-flop.

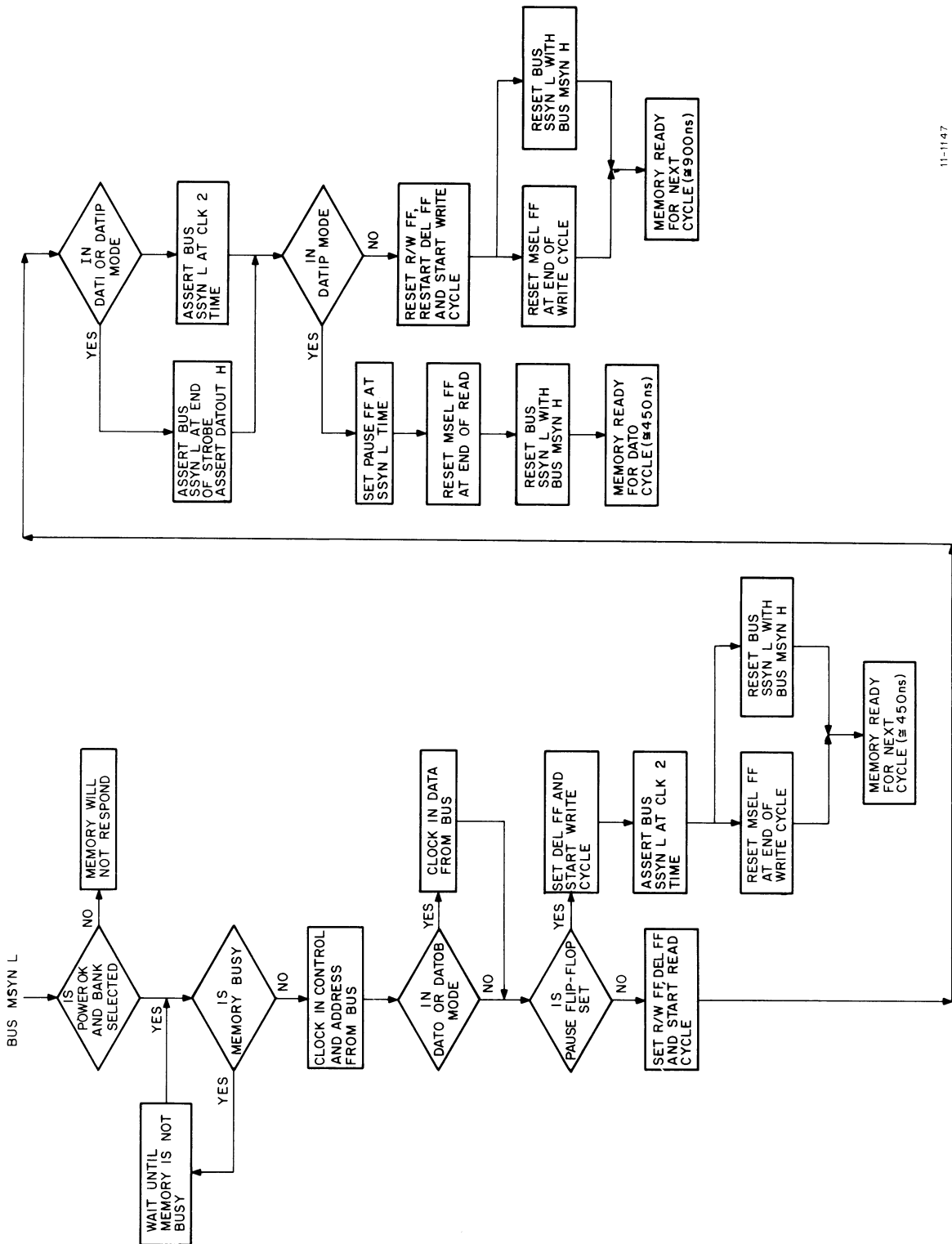

11-1147

Figure 12-26 Flow Chart For Memory Operation

12.9.6 Data In Pause (DATIP) Operation

In a DATIP operation, the master requests that a selected memory location be read and the information transferred to the master via the Unibus. However, unlike the DATI, this information is not to be restored after reading; this location is to have new information written into it. The DATIP performs only a read operation; the write operation is inhibited. A DATIP must always be followed by a write operation (either DATO or DATOB).

The read operation of a DATIP is identical to that of a DATI (Paragraph 12.9.5) until the time the SSSYN flip-flop is reset (clocked by STROBE H). At this time, the SSSYN flip-flop output clocks the PAUSE flip-flop, which sets it because its D-input is a 1 (only during DATIP due to the state of mode control bits C01 and C00). The timing chain generates R/W RESET L which resets the R/W flip-flop. The outputs of the PAUSE flip-flop and R/W flip-flop prevent the pause/write restart circuit from generating WRITE RESTART L. With this signal inhibited, the write operation is not produced. The timing chain generates DELAY FF RESET L, which resets the DEL flip-flop and terminates TNAR H and TWID H. The timing chain also generates MSEL RESET L, which resets the MSEL flip-flop.

The memory is now ready to accept another request from the master. The next operation must be a DATO or DATOB. Normally, a DATO or DATOB starts with a read operation to set all selected cores to zero (clear) before writing new information into them. A DATO or DATOB following a DATIP has this initial clear operation eliminated because the cores have been cleared by the previous DATIP operation.

The DATO or DATOB following a DATIP starts when the master asserts BUS MSYN L. Pulse CLK 1 is generated but it does not set the R/W flip-flop because the PAUSE flip-flop is set. The master places the information to be written on the Unibus where it is picked off by bus receivers and sent to the D-input of the MDR flip-flops. Decoding the mode control bits (C01 and C00) for a DATO or DATOB generates LOAD 0 H and LOAD 1 H, which clock the MDR flip-flops. The outputs of the MDR flip-flops are gated with TINH 0 H and TINH 1 H to control the associated inhibit drivers to write 1s or 0s into the selected memory location. As in the write operation of a DATI, the timing chain generates TWID H and TNAR H which select the appropriate write drivers and switches; turn on the X- and Y-current generators; and control the stack discharge circuit. They also generate inhibit driver control signals TINH 0 H and TINH 1 H. Signal CLK 2 H clocks the SSSYN flip-flop (resets it), which asserts BUS SSSYN L to tell the master that the data has been taken from the Unibus. When the master clears BUS MSYN L, the SSSYN flip-flop is reset, which in turn resets the PAUSE flip-flop. At the end of the write operation, the timing chain generates DELAY FF RESET L and MSEL RESET L to restore the control signals to their original states.

12.9.7 Data Out (DATO) Operation

In a DATO operation, the master sends a 16-bit word to be written into the selected memory location. The transaction starts with a read (clear) operation to set the selected cores to 0 before writing new data into them. The standard DATO consists of a read operation followed by a write operation. (As described in Paragraph 12.9.6, a DATO following a DATIP does not perform the read operation.)

The read operation of a DATO is similar to a read operation of a DATI except that no RESET 0 L, RESET 1 L, STROBE 0 H, and STROBE 1 H pulses are generated. The MDR is not cleared and the sense amplifiers are not strobed. This read operation is required only to clear the memory location by setting all the selected cores to 0; it is not necessary to readout and store the information in the MDR. The information on the Unibus data lines is sent to the inputs of the MDR flip-flops. Decoding the mode control bits (C01 and C00) generates LOAD 0 H and LOAD 1 H, which clock the MDR flip-flops. The MDR outputs (16 bits) are gated with TINH 0 H and TINH 1 H to control the associated inhibit drivers. The timing chain generates the other control signals that provide the selection of the appropriate write drivers and switches and a write operation is initiated. This write operation is the same as that described in Paragraph 12.9.6 for a DATO following a DATIP.

12.9.8 Data Out Byte (DATOB) Operation

In a DATOB operation, the master sends a byte (8 bits) to be written into the selected memory location. A high byte [bits D (15:08)] or a low byte [bits D (07:00)] can be selected. Byte selection is made by the state of address bit A00. A DATOB is the same as a DATO except that the selected and non-selected bits are handled differently.

Assume that the low byte [bits D (07:00)] is selected (A00 = 0). Neither RESET 0 L or STROBE 0 H are generated for the selected byte because new data is to be written into bits D (07:00) (low byte). The LOAD 0 H signal is generated so that the data on Unibus bits D (07:00) can be written into the selected byte location.

The non-selected byte [bits D (15:08)] is to be restored so that RESET 1 L and STROBE 1 H are generated. These signals strobe the byte into the MDR for restoration during the write operation. Restoration is necessary because this byte does not receive new data. The LOAD 1 H signal is not generated; therefore, any data on Unibus bits D (15:08) has no effect on the non-selected byte.

When the DATOB is complete, the selected byte contains new data and the non-selected byte remains unchanged. A DATOB operation following a DATIP is the same, except that the read portion is eliminated.

CHAPTER 13

MEMORY MAINTENANCE

13.1 INTRODUCTION

This chapter provides the preventive and corrective maintenance procedures for the MM11-K and L memories. The user should have a thorough understanding of the normal operation of the memory (Chapter 12). This knowledge plus the maintenance information will aid the user in isolating and correcting malfunctions.

13.2 PREVENTIVE MAINTENANCE

Preventive maintenance consists of specific tasks performed at intervals to detect conditions that could lead to subsequent performance deterioration or malfunction. The following tasks are considered preventive maintenance items.

- a. Visual inspection of modules for broken wires, connectors, or other obvious defects.
- b. +5V and -15V checks: both must be within $\pm 3\%$.
- c. X- and Y-current generator check (Paragraph 13.2.2).

Two pieces of test equipment are recommended for checking and troubleshooting the memory: Tektronix 453 Dual Trace Oscilloscope or equivalent, and Honeywell 33R Digital Voltmeter or equivalent with 0.5 percent accuracy.

13.2.1 Initial Procedures

Before attempting to check, adjust, or troubleshoot the memory, perform the following steps.

NOTE

All tests and adjustments must be performed in an ambient temperature range of 20°C to 30°C (68°F to 86°F).

1. Verify that all modules are properly and securely installed.

CAUTION

Ensure that all power is off before installing or removing modules.

2. Visually check modules and backplane for broken wires, connectors, or other obvious defects.
3. Verify that power buses are not shorted together.
4. Turn on primary power and check that both the -15V and +5V power are present and within tolerances ($\pm 3\%$).

5. Start the system. The memory should operate without errors. If not, check the output of the current generator (Paragraph 13.2.2). If the memory still does not operate properly, a malfunction has occurred. Proceed with corrective maintenance (Paragraph 13.3).

13.2.2 Checking Output of Current Generators

The amplitude of the current pulse from each current generator (X and Y) is factory set at 410 ± 5 mA. It is not adjustable in the field.

The X- and Y-current generators are located on the G231 Driver Module. Each output has a current loop on its output line for attaching a test probe. Loop J5 is for the Y-generator and loop J6 is for the X-generator (drawing G231-0-1, sheet 2). The amplitude of each READ current pulse should be 410 ± 5 mA. At the time of measurement, -15V and +5V power must be within the specified tolerance of ± 3 percent.

13.3 CORRECTIVE MAINTENANCE

This paragraph describes the method of interchanging the positions of the memory modules to gain access to test points. It also describes the strobe delay adjustment, which is a specific corrective maintenance procedure. Further, three aids are included for performing corrective maintenance: a troubleshooting chart and waveforms for the drive and sense/inhibit circuits.

13.3.1 Strobe Delay Check and Adjustment

CAUTION

Strobe delay is factory adjusted and should be adjusted only when one of the three modules is replaced. It is a critical adjustment and must be done carefully.

The strobe must be set while cycling worst-case noise test patterns (MAINDEC-11-DIGA). The proper setting is midway between the two end points where the memory starts to error as strobe time is moved from earliest to latest. As the strobe time is varied, allow adequate time to cycle completely through the worst-case noise test at each strobe position. Figure 13-1 shows the strobe pulse waveform and the READ pulse waveform and the points at which they are picked off for display. Strobe-adjusting potentiometer R120 is on the G110 module next to the large delay line (DL1) and is accessible without putting the module on the extender.

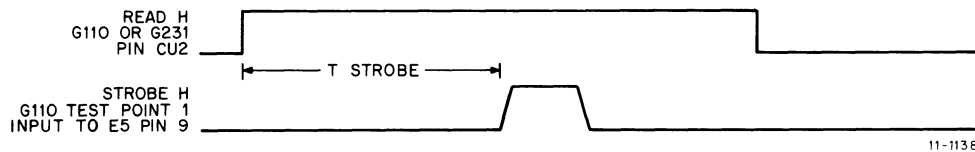

Figure 13-1 Strobe Pulse Waveform

13.3.2 Corrective Maintenance Aids

Figure 13-2 is a troubleshooting chart arranged as a two-axis grid that identifies faults versus cause location. Figure 13-3 illustrates the sense/inhibit waveforms, and Figure 13-4 illustrates the drive waveforms. Both figures include schematics to indicate the points in the circuit where the waveforms occur. In addition to nominal waveforms, dotted lines are used to indicate waveforms that appear if specific components are faulty.

Failure Symptom	Loc.		Possible Circuit																																									
	C	C	-5.1V	Device Selection or Jumpers	DELAY Flip-Flop or DELAY Line	MSEL Flip-Flop	SSYN Flip-Flop	PAUSE Flip-Flop	READ Flip-Flop	Write Restart Flip-Flop	STROBE H	RESET L	LOAD H	TINH H	DATA OUT H	INIT L Circuit	BALUN Transformer	Bus Receiver-Driver	Sense Amplifier or Terminator	Data Latch	Inhibit Driver	20-mV Threshold	Stack S/I Line	Stack X-Y Line	Stack Diode	Stack Resistor-Thermistor	X-Y Volt Reference Circuit	Stack Discharge Circuit	X I Generator	Y I Generator	YDR	YSS	XDR	XSS	TDR-TSSH	DC LO L Circuit	4K-8K Jumper	Backplane	+5V	-15V				
Memory Does Not Respond to MSYNL		X	X	X	X					X	X				X		X																				X	X	X					
Memory Hangs Bus						X																																						
DATO Fails												X			X		C00 C01		X																						X			
DATIP Fails							X								X		C00 C01																											
Many Bits Fail	X													X																										X	X			
Picks Bits	Lo										Lo								X	X							Lo	X	Hi	Hi												Lo		
Drops Bits	Hi										Hi																Hi	X	Lo	Lo														
Byte Failures											X	X	X	X			A0																											
4 Bits Fail																X	X					X																						
2 Bits Fail																		X	X																									
1 Bit Fails																			X	X			X																		X			
Fails All Addresses	X	X													X											X	X	X	X							X	X			X	X	X		
A1-A3 Common																								X	X				X															
A4-A6 Common																							X	X					X															
A7-A9 Common																							X	X					X	X														
A10-A13 Common																							X	X					X															
READ Waveforms Wrong																											X		X	X	X	X	X	X	X	X	X							
WRITE Waveforms Wrong												X															X		X	X	X	X	X	X	X	X								
No Inhibit													X							X			X																				X	

Location { C = G110 Sense Control
S = Stack
D = G231 Driver

X = Indicates Circuit Not Operable
Lo = Measured Parameter Too Low or Early
Hi = Measured Parameter Too High or Late

Figure 13-2 Troubleshooting Chart

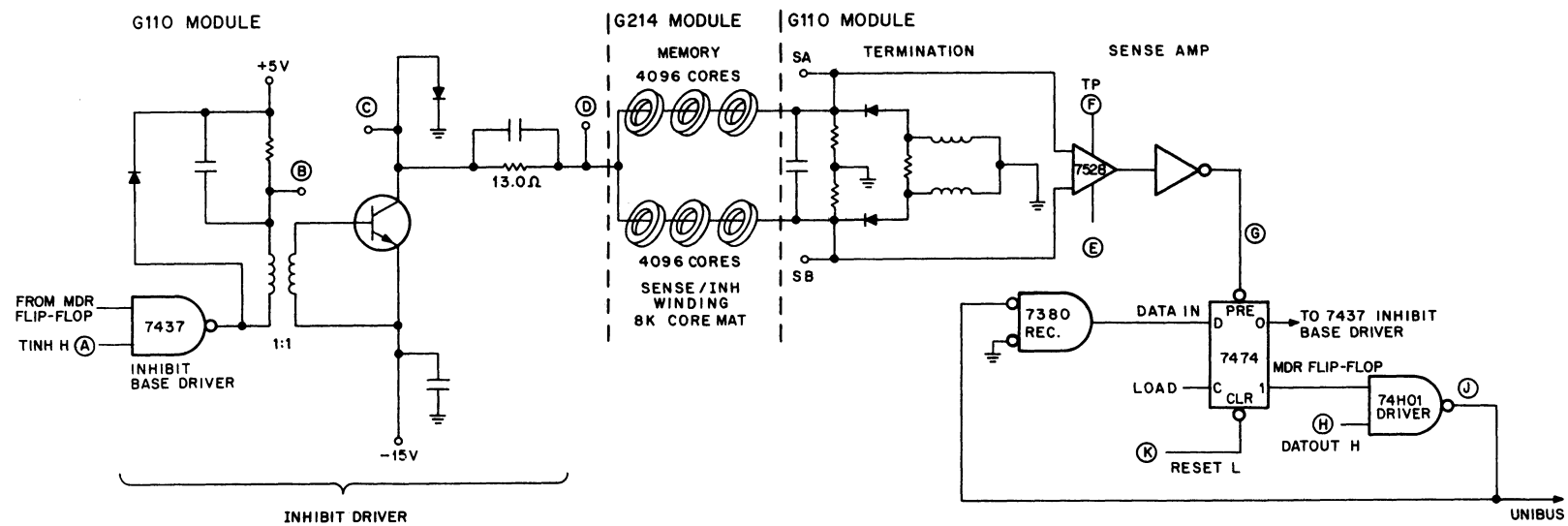

11-1151

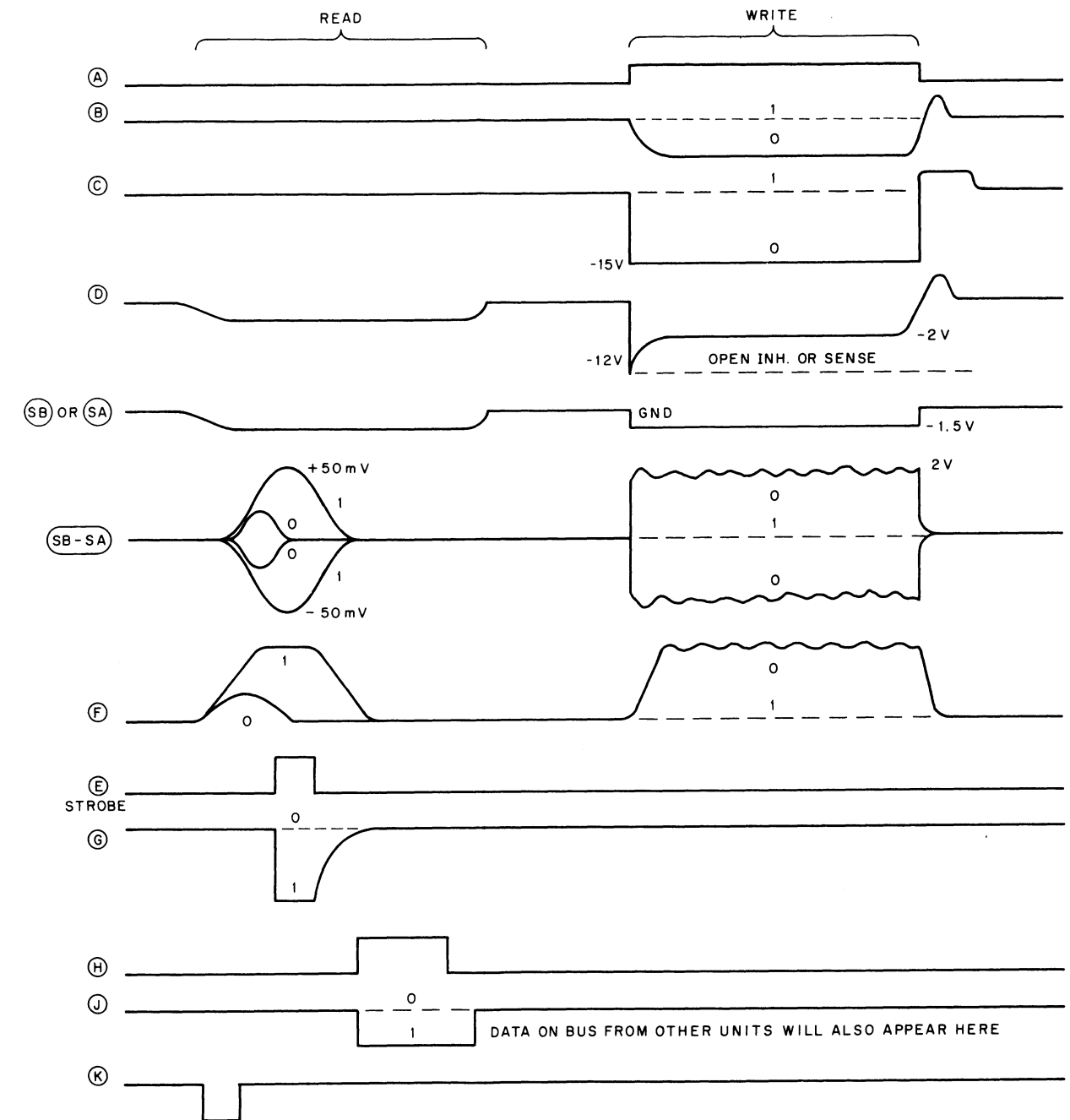

11-1152

Figure 13-3 MM11-K Sense/Inhibit Waveforms

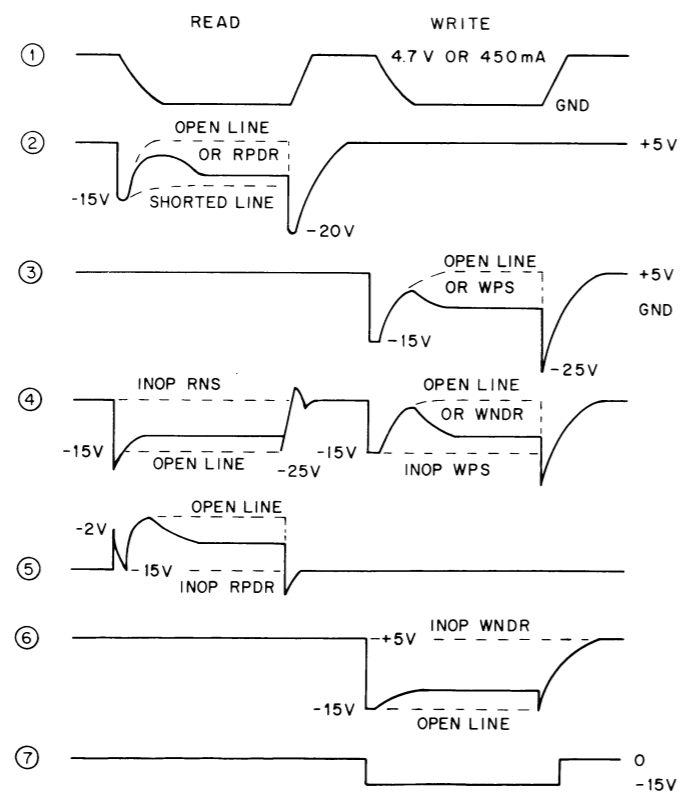

---- Dotted line show possible failure waveforms.

11-1154

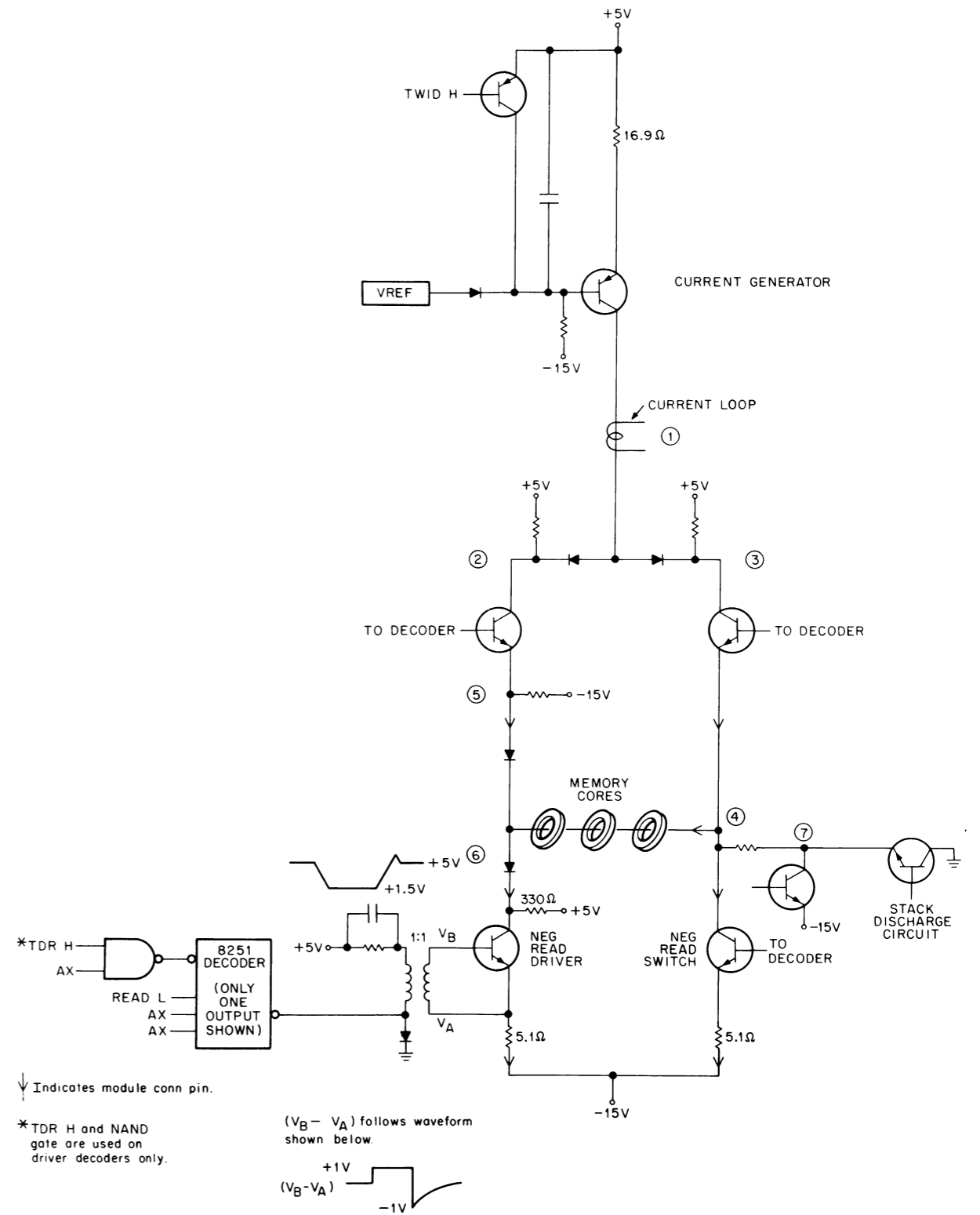

11-1153

Figure 13-4 Drive Waveforms

13.4 PROGRAMMING TESTS

Certain DEC programs may be used to test various memory operations as an aid to troubleshooting. The purpose of each of these memory-related test programs, as well as the program abstract, is given in the following paragraphs. Each program contains instructions for use.

13.4.1 Address Test Up (MAINDEC-11-DIAA)

The purpose of the Address Test Up program is to demonstrate that the selected memory area is capable of basic read and write operations when address propagation is upward through memory. This test program writes the address of each memory location (within the test limits) into itself and then increments through memory until the address corresponding to the high limit is reached. After this location has been written, the memory enters the read cycle. The read cycle starts with the high limit location and reads and compares each word location, decrementing down to the low limit location. The program halts on an error.

The program ensures that all addresses are selectable and can also be used to isolate bad switches, wiring errors, or address selection errors. It will also find double selection errors when two bus addresses select the same core address.

13.4.2 Address Test Down (MAINDEC-11-DIBA)

The purpose of the Address Test Down program is to demonstrate that the selected memory area is capable of basic read and write operations when address propagation is downward through memory. It is a companion test to the Address Test Up program (Paragraph 13.4.1).

This test program writes the address of each location into itself, downward through memory. After writing down, the program reads and checks back up through the memory test area. The program halts on an error.

The Address Test Down program resides in the high portion of core memory. It does not check memory below address 100, as these locations are reserved for trap and vector locations. The program verifies that all modules can perform their basic functions, checks that all addresses are selectable, and can also be used to isolate faulty switches, wiring errors, or address selection errors.

13.4.3 No Dual Address Test (MAINDEC-11-DICA)

The purpose of the No Dual Address Test program is to check the unique selection of each memory address tested. This test is divided into two parts. The first portion of the test fills the test field with 1s and writes 0s into the first test location. This is followed by a read check from this location. The program then checks each field location to ensure there are no variations from the 1s configuration. Upon completion of this test, the test location pointer is incremented. The next location is then write/read exercised with 0s, and the test field rechecked for any change in content. When the selected test field has been tested in this mode, the program sets a flag and the second portion of the test is begun. The program fills the test field with 0s and the field is then tested with a write/read exercised with 1s.

This program checks for faulty switches or wiring errors, checks the complete address selection scheme, and checks all 16 bits in the data field for 1s and 0s operation.

13.4.4 Basic Memory Patterns Test (MAINDEC-11-DIDA)

The Basic Memory Patterns Test program has two main purposes:

- a. Verify that the selected memory test field is capable of writing and reading fixed data patterns.
- b. Verify that the memory plane is properly strung.

This test program writes a specific pattern throughout a given memory zone, then reads the pattern back and compares it with the original for correctness. If the pattern read fails to compare correctly with the original, the program initiates a call to the error subroutine. After completely checking the pattern, the program continues on to the next pattern test.

13.4.5 Worst-Case Noise Test (MAINDEC-11-DIGA)

The purpose of the Worst-Case Noise Test program is to generate the maximum possible amount of plane noise during execution of memory reference instructions to check system operation under worst-case conditions.

This test program is designed to produce the greatest amount of plane noise possible during memory read and write cycles. The noise parameters are affected by a number of factors. The noise generated is distributed across the core plane algebraically and adds to the normal dynamic noise present on the sense lines. This can cause misreading of data (within the plane) that is in the low (1) or high (0) category. The sense windings of most memories are such that worst-case patterns can be caused by alternately writing -1 and 0 data configurations throughout memory. Under these conditions, worst-case noise is generated by performing a read, write, complement operation at each location. The test is repeated after complementing all of the pattern data stored in the memory test zone; thus, all cores are tested for worst-case as both 1s and 0s. The pattern or its complement is written into the memory test zone as determined by the exclusive-OR between address bits 3 and 9.

The Worst-Case Noise Test program is divided into two parts. Part 1 is run first and, during this part of the program, a -1 configuration is written into all locations having an address with an exclusive-OR state between bits 3 and 9. All other locations are loaded with the 0 configuration. After the test zone has been loaded, the memory is rescanned. This time, each location is read, complemented, read, and complemented (RCRC). Any location detected as being disturbed by a previous RCRC operation is flagged as an error. Upon conclusion of the read scan loop, the program automatically switches to Part 2.

During Part 2 of the program, the data patterns stored in memory are complemented. In other words, 0 patterns are stored in locations having addresses with an exclusive-OR between bits 3 and 9. All other locations are loaded with the -1 configuration.

The exclusive-OR pattern distribution for Parts 1 and 2 is summarized for reference as follows:

Part 1
Exclusive-OR (3 and 9) = 1 pattern
No Exclusive-OR (3 and 9) = 0 pattern

Part 2
Exclusive-OR (3 and 9) = 0 pattern
No Exclusive-OR (3 and 9) = -1 pattern

After memory is loaded, it is scanned again with a read, complement, read, complement (RCRC) loop as previously described. Any location detected as being disturbed by a previous RCRC operation is flagged as an error.

Before writing or reading any location (in either part of the program), the program issues a call to subroutine XORCK (exclusive-OR check) that tests bits 3 and 9 and sets the XORFLG if the exclusive-OR condition is present.

Subroutine ERRORA is called for any location disturbed from the -1 configuration; subroutine ERRORB is called for any location disturbed from the 0 configuration.

The program prints out errors and repeats when complete without interruption. Upon completion, the program rings the teletype bell and then halts if switch 12 is present. A continue from the halt initiates another pass.

If the program indicates an error, use the troubleshooting chart as a guide to locate the fault.

PART 4

POWER SUPPLY

Part 4 provides specifications and a general physical description of the power supply. A detailed circuit description and maintenance information are also included. The chapters of Part 4 are:

- Chapter 14 – Power Supply General Description
- Chapter 15 – Power Supply Detailed Description
- Chapter 16 – Power Supply Maintenance

CHAPTER 14

POWER SUPPLY GENERAL DESCRIPTION

14.1 INTRODUCTION

The power supply is a forced air-cooled unit that converts single-phase 115V or 230V nominal, 47-63 Hz line voltage to the three regulated output voltages required by the computer. The output voltages and their principal uses and characteristics are:

Voltage	Use	Characteristics
+15V	Communication Circuits	Series regulated and overcurrent protected.
+5V	IC Logic	Switching regulated and overvoltage and overcurrent protected.
-15V	Core Memory	Switching regulated and overvoltage and overcurrent protected.

The power supply is used in conjunction with the BC05HXX (115V) or BC05JXX (230V) Power Control Assemblies, which contain a line cord, circuit breaker, and RFI capacitors. Line cord length is specified in the part number; e.g., 115V, 6 feet is designated BC05H06.

The power circuitry also generates BUS AC LO L and DC LO L power fail early warning signals, and the LTC L real-time clock synchronizing signal.

A thermal control mounted on the heat sink will interrupt the ac input should the heat sink temperature become excessive due to fan failure or other cause.

14.2 PHYSICAL DESCRIPTION

The power supply comprises three major subassemblies and two cables: the power control unit, power chassis assembly, dc regulator module, dc cable, and ac cable.

14.2.1 Power Control Unit

The power control unit (drawing H400-0-0) is mounted to the rear of the computer by two screws. It contains line cord, circuit breaker, RFI capacitors, 115V or 230V connections for the power supply transformer, and an output 6-socket Mate-N-Lok connector. Physically, it consists of a sheet metal bracket and a slide-on cover that is locked in place by one screw. A single pole thermal breaker and a line cord strain-relief grommet are mounted on the flange of the bracket, making the line cord and breaker reset button accessible on the rear of the computer.

A small printed circuit card is mounted directly to the breaker terminals. This card interconnects and mounts the RFI dual-disc ceramic capacitor, the output Mate-N-Lok connector and three fast-tabs for ac input and ground connections. A dual fast-tab is connected directly to the bracket. The black and white line cord wires are connected via fast-tab to the PC card; the green (ground) line cord wire is connected to the dual fast-tab, which in turn is connected to the third fast-tab on the PC card.

The 115V and 230V models differ in only two respects: breaker current rating and (printed circuit) jumpers for parallel or series connection of the power supply transformer primaries. Power control part numbers are: BC05HXX - 115V, 7A; and BC05JXX - 230V, 4A; where XX denotes line cord length; e.g., BC05H06 has a 6 foot line cord.

14.2.2 Power Chassis Assembly

The 700 8731 Power Chassis Assembly (Figures 14-1 and 14-2) consists of a long, inverted U-shaped chassis, 700-8726 power transformer, and a 5-inch fan. It is secured to the bottom of the computer by four 8-32 by 3/8 inch Phillips pan-head bolts.

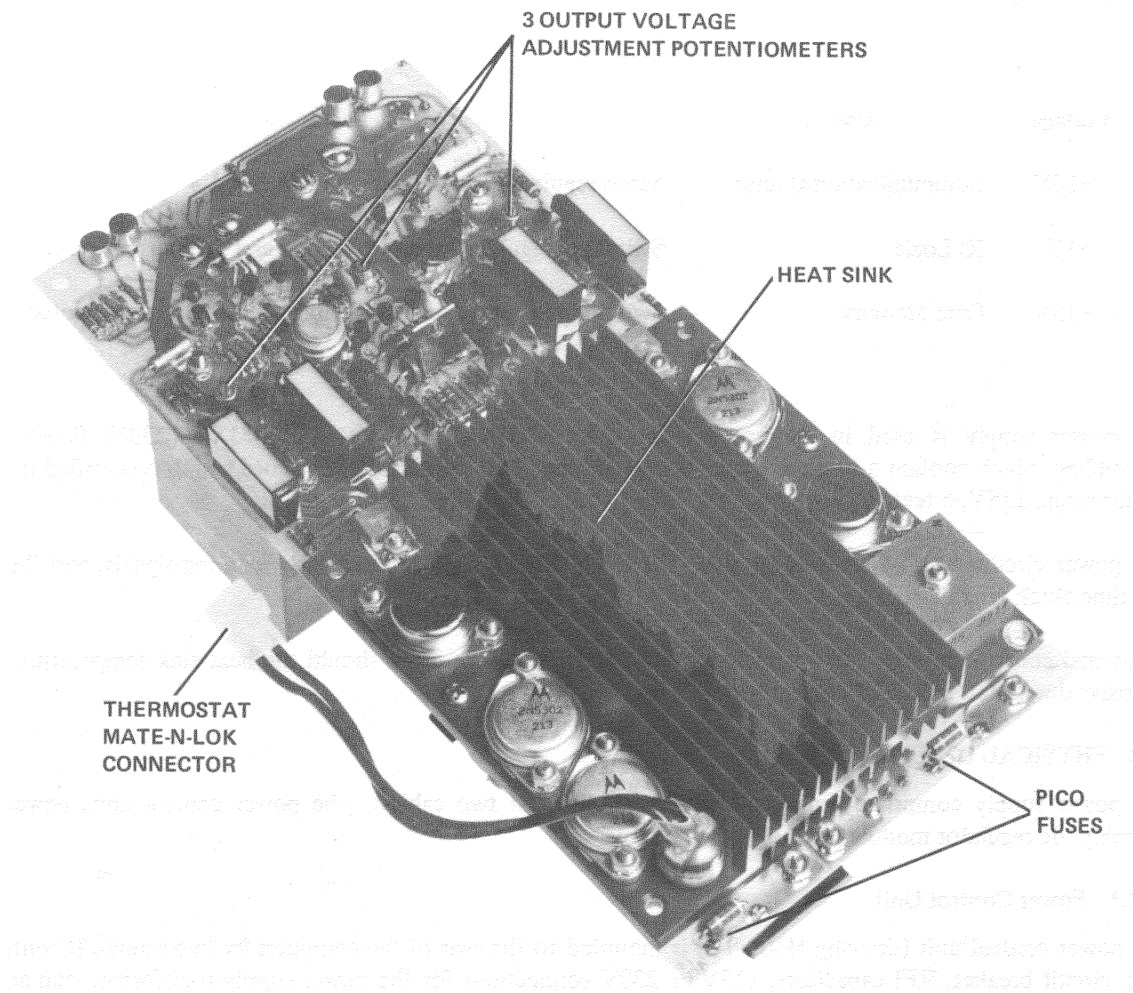

Figure 14-1 Power Chassis Assembly (with DC Regulator Module)

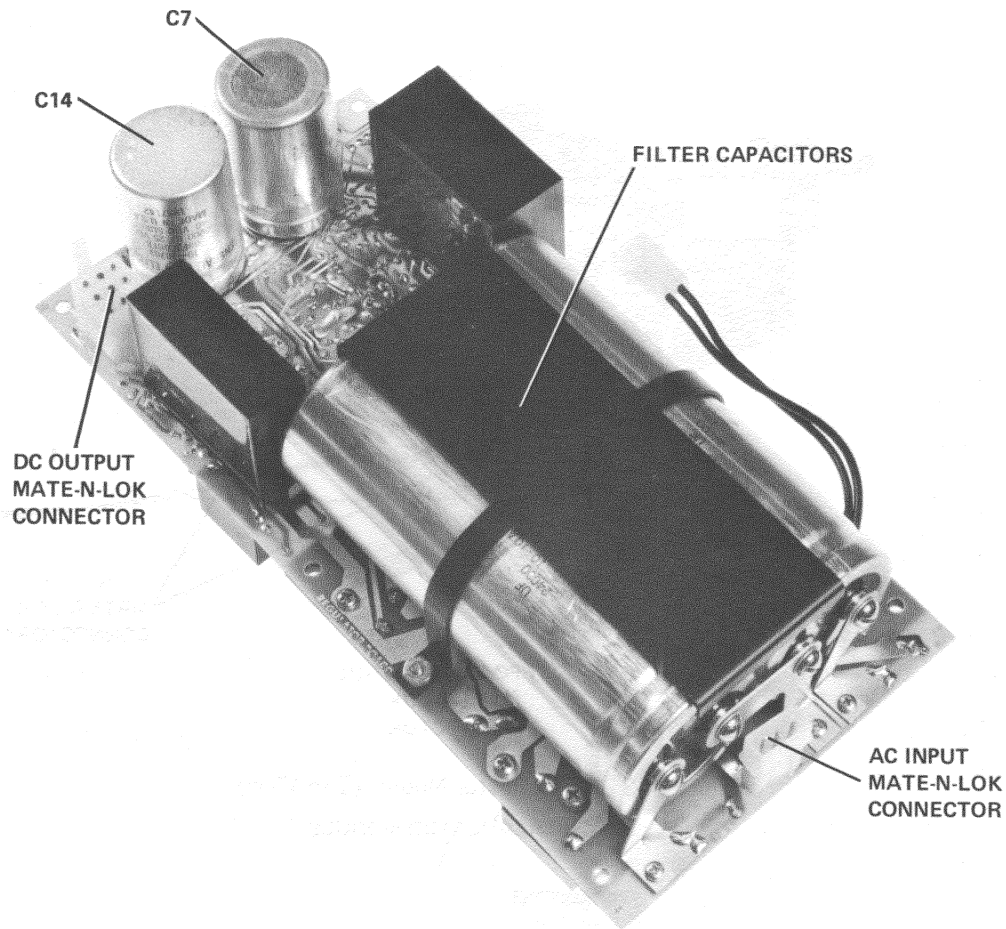

Figure 14-2 Power Supply Assembly (with DC Regulator Module Removed)

The chassis is mounted to the right of the connector blocks, when viewed from the front, and airflow is from front to rear. The fan is held to one end of the chassis by two screws; the transformer is held to the other end by four mounting studs. The transformer may be removed by loosening four nuts, which are accessible through large holes on the bottom of the power chassis.

The dc regulator module is mounted to the chassis assembly by six screws and must be removed for cable access. The dc cable enters a slot on the connector block side of the chassis; the ac cable enters a slot on the other side.

Connections to the fan are made by small fast-tabs; connections to the transformer are made via Mate-N-Lok connectors: 6-pin for primary, 3-socket for secondary.

14.2.3 DC Regulator Module

The 5409728 DC Regulator Module (Figures 14-3 and 14-4) is a printed circuit assembly, mounted to the power chassis assembly by four 6-32 by 9/16 inch and two 6-32 by 1/4 inch Phillips pan-head screws.

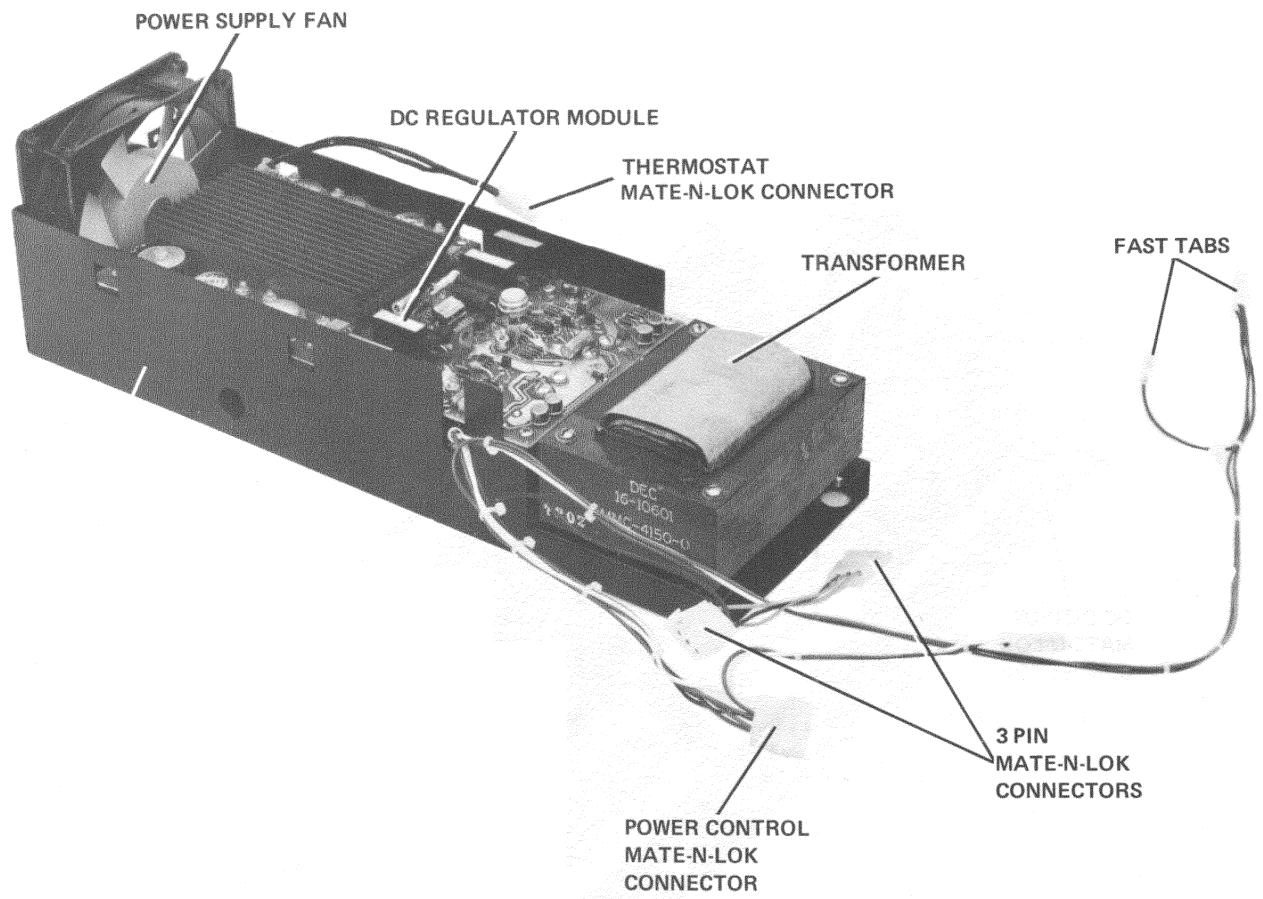

Figure 14-3 DC Regulator Module (Top View)

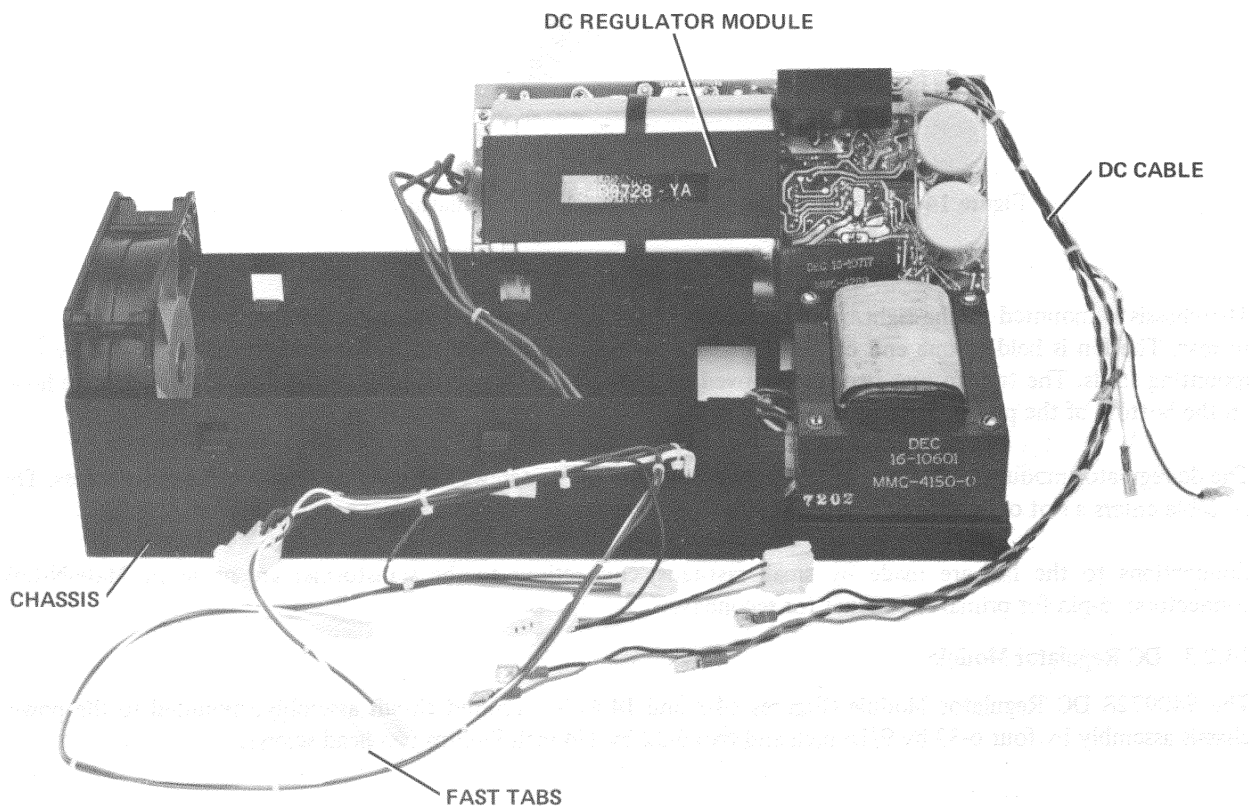

Figure 14-4 DC Regulator Module (Bottom View In Mounting Box)

Computers that were shipped during the first three or four months of production use a dc regulator module designated 5409728-YA-0; later shipments use a module designated 5409728-0-0, E revision. There are differences in component values on the two modules. The discussion of the dc regulator module circuits in this manual is directed to the later module, designated 5409728-0-0. Engineering drawings applicable to the module used are shipped with the equipment. These drawings provide schematics and component values of the dc regulator module.

This module contains all the circuitry between the transformer secondary winding and the power supply output cable. The transformer secondary 3-socket Mate-N-Lok connector is plugged into a mating connector that is soldered directly to the printed circuit board and is accessible underneath it. The 9-pin Mate-N-Lok connector on the dc output cable to the computer is similarly mated to a connector underneath the other end of the board.

The dc regulator module may be probed for troubleshooting purposes from the top; all points on the circuit are available. It may also be removed from the top for cable access and for parts replacement by removing the six mounting screws.

The printed circuit is approximately 5 by 10 inches, with about half of the top surface devoted to the heat sink. The power transistors and power rectifiers are bolted to two shelves on the sides of the heat sink and make contact with the circuit board directly underneath via solder and screw connections. The heat sink is hard anodized for electrical insulation.

The other half of the top surface is devoted to interconnecting and mounting the balance of the circuit. Three small output voltage adjustment potentiometers are accessible on this top portion of the board.

Two small pico fuses are mounted on the top of the PC board on the fan end. These fast-acting fuses will typically only blow when some component is defective or when the +5V or -15V is too high. The two input filter capacitors are held to the underside of the board by a bracket and are connected to the circuit via jumper tabs on the fan end.

The +5V and -15V output filter capacitors and inductors are also mounted under the board, the former by screws and the latter by nuts.

Care must be taken to ensure that all electrical and mechanical connections are secure. In manufacturing, the hardware is tightened with a torquing device set to 12 inch-pounds.

14.2.4 DC Cable

This is a simple cable connecting the computer module to the dc power module via a 9-pin Mate-N-Lok. The latter is made accessible by loosening the six mounting screws and lifting out the dc module. Cable access is through a slot on the computer module side of the power chassis.

14.2.5 AC Cable

This cable interconnects all ac portions of the computer chassis (Figures 14-1 through 14-4). The ac portions of the computer chassis are as follows:

- a. Power Supply Fan – two fast-tabs
- b. Power Supply Thermostat – one 2-pin Mate-N-Lok
- c. Memory Section Fan – two fast-tabs
- d. Transformer Primary – one 6-socket Mate-N-Lok
- e. Power Control – one 6-pin Mate-N-Lok
- f. PDP-11 System AC Power Control – two 3-pin Mate-N-Lok connectors on rear of computer.

The ac cable is located on the right-hand side and rear of the computer and is inherently shielded by the power supply chassis and the computer chassis.

14.3 Specifications

Tables 14-1, 14-2, and 14-3 list all the power supply specifications according to input, output, and mechanical and environmental specifications.

Table 14-1
Power Supply Input Specifications

Parameters	Specifications
*Input Voltage (1 phase, 2 wires and ground)	95–135/190–270V
Input Frequency	47–63 Hz
Input Current	5/2.5A RMS
Input Power	325W at full load
Inrush	80/40A peak, 1 cycle
Rise Time of Output Voltages	30 ms max. at full load, low line
Input Overvoltage Transient	180/360V, 1 sec 360/720V, 1 ms
Storage After Line Failure	25 ms min., starting at low line, full load
Input Breaker (part of BC05 Power Control)	7A/4A single-pole, manually reset, thermal
Thermostat Mounted on Heat Sink (opens transformer and fan power)	277V 7.2A contacts Opens 98–105°C Automatically resets 56–69°C
Input Connections	Line cord on BC05 Power Control, length and plug type specified with BC05 (Paragraph 2.2.1.1)
Turn-On/Turn-Off	Application or removal of power
Hipot (input to chassis and output)	2.1 kV/dc, 60 sec

*Input voltage selection, 115V or 230V, is made by specifying the appropriate AC Input Box, DEC Model BC05. All specifications are with respect to the BC05 input.

**Table 14-2
Power Supply Output Specifications**

Parameter	Specification
+15V	
Load Range	
Static	0–1A
Dynamic	0–1A
Max. Bypass Capacitance in load for 30 ms turn-on	500 mF
Overvoltage protection	None
Current limit at 25°C	1.3A to 1.7A (-6.2 mA/°C)
Backup Fuse	15A (also used for +5V)
Adjustment	±5% min.
Regulation (All causes including line, load, ripple, noise, drift, ambient temperature)	±5%
+5V	
Load Range	
Static	0–15A
Dynamic #1	±5A (within 0–17A load range)
Dynamic #2	No load – full load
Max. Bypass Capacitance in load for 30-ms turn-on	2000 μF
Overvoltage Crowbar (blows fuse)	5.7–6.8V actuate (7V abs. max. output)
Current Limit at 25°C	24–29.4A (-0.1A/°C)
Backup Fuse (series with raw dc)	15A
Adjustment Range	±5% min.
Regulation	
Line	±0.5%
Static Load	3%
Dynamic Load #1	±2%
Dynamic Load #2	±10%
Ripple and Noise	4% peak-to-peak
1000 Hour Drift	±0.25%
Temperature (0–60°)	±1%

Table 14-2 (Cont)
Power Supply Output Specifications

Parameter	Specification
-15V	
Load Range	
Static	0–7A
Dynamic #1	$\Delta I = 5A (0.5A/\mu s)$
Dynamic #2	No load – full load (0.5A/ μs)
Max. Bypass Capacitance in load for 30-ms turn-on	1000 μF
Oversvoltage Crowbar (blows fuse)	17.4–20.5V (22V abs. max. output)
Current Limit at 25°C	10–13.3A (–0.03A/°C)
Backup Fuse (series with raw dc)	5A
Adjustment Range	$\pm 5\%$ min.
Regulation	
Line and Static Load	$\pm 1\%$
Dynamic Load #1	$\pm 2.5\%$
Dynamic Load #2	$\pm 3\%$
Ripple and Noise	3% peak-to-peak
1000 Hour Drift	$\pm 0.25\%$
Temperature (0–60°C)	$\pm 1\%$
BUS DC LO L and BUS AC LO L	
<i>Static Performance at Full Load</i> (for 230V connection, double below voltages)	
BUS DC LO L goes to high	74–80 Vac line voltage
BUS AC LO L goes to high	8–11V higher
BUS AC LO L drops to low	80–86 Vac line voltage
BUS DC LO L drops to low	7–10V lower
Hysteresis (contained in above specifications)	3–4 Vac
Output voltages still good	70 Vac line voltage

Table 14-2 (Cont)
Power Supply Output Specifications

Parameter	Specification
BUS DC LO L and BUS AC LO L (Cont)	

Dynamic Performance

Worst case on power-up is high line, full load.

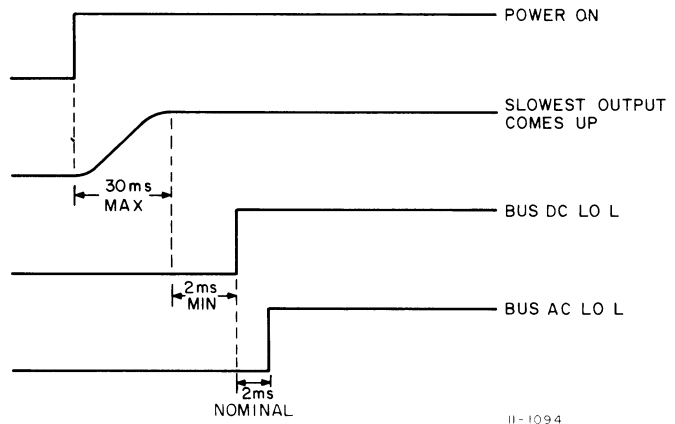

Worst case on power-down is low line, full load.

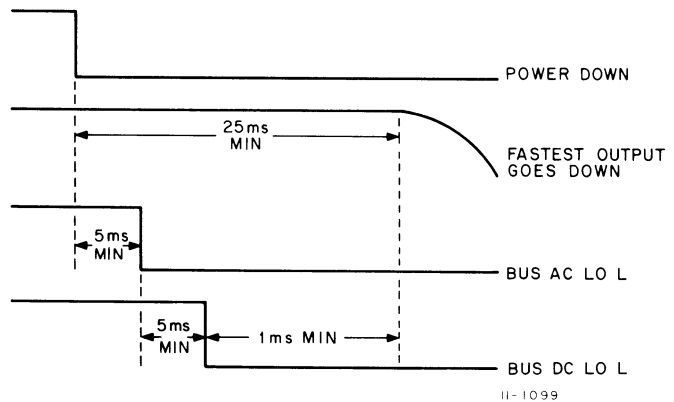

Output Characteristics

Open Collector	50 mA sinking capability +0.4V max. offset
Pull-Up Voltage on Unibus	5V nominal, 180Ω impedance
Rise and Fall Times	1 μs max. Outputs shall remain in 0 state subsequent to power failure until power is restored despite Unibus pulling voltages remaining.

**Table 14-3
Mechanical and Environmental Specifications**

Parameter	Specification
Weight	
DC Regulator	7 lb approx.
Power Chassis Assembly including AC Regulator Module	18 lb approx.
Dimensions	16.50 in. length 5.19 in. width 3.25 in. height
Cooling Means	Integral 5 in. fan
Minimum Cooling Requirements	375 CFM through heat sink 250 CFM over caps, chokes, and transformer
Rated Heat Sink Temperature	95°C max.
Shock, Non-Operating	40G (duration 30 ms) 1/2 sine in each of six orientations
Vibration, Non-Operating	1.89G RMS average, 8G peak; varying from 10 to 50 Hz, 8 dB/octave roll-off 50–200 Hz; each of six directions
Ambient Temperature	0 to +60°C operating -40 to +71°C storage
Relative Humidity	95% max. (without condensation)
Altitude	10K ft

Output parameters are specified at the pins of the 9-pin Mate-N-Lok connector (Figure 14-5) which plugs into the output connector on the 5409728 module. All output voltages are given with respect to the common ground pin on this connector. IR drops in the distribution wiring are minimized to achieve good regulation at the load.

- Pin 1 BUS AC LO L
- Pin 2 Common
- Pin 3 +5V output
- Pin 4 LTCL (Clock Signal)
- Pin 5 +15V output
- Pin 6 BUS DC LO L
- Pin 7 Not used
- Pin 8 Not used
- Pin 9 -15V output

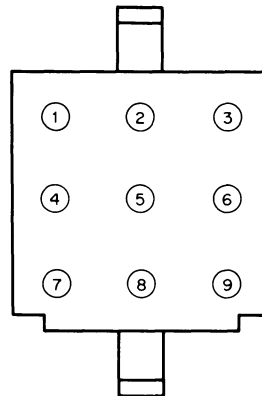

- NOTES:
1. The circuit connected to pins 7 and 8 is not used in the PDP-11.
 2. Pin 2 is not connected to chassis within the power supply. Chassis ground is made at the backplane.

Figure 14-5 Output Connector, 5409728 Regulator Module

CHAPTER 15

POWER SUPPLY DETAILED DESCRIPTION

15.1 INTRODUCTION

The power supply is divided into two sections: the ac input circuit and the dc regulator module. A detailed description to the circuit level is provided for each section. The ac input circuit description discusses the power supply interconnections, power control, power switch, transformer, power control circuit breaker, and the power supply thermostat. The dc regulator module operation description discusses the generation at the circuit level of each of the five power supply outputs.

15.2 AC INPUT CIRCUIT

A detailed ac interconnection diagram is shown in Figure 15-1. Figures 15-2 and 15-3 give this information in schematic form.

The line cord, single pole breaker, RFI capacitors, and connections for transformer 115V or 230V wiring are contained in the power control unit. To select 115V input or 230V input, use the BC05H or BC05J power control unit, respectively.

A 3-section managed keyswitch is employed and mounted on the console. One section interrupts the power to the transformer primary. A second section is wired to two 3-pin Mate-N-Loks; if the PDP-11 cabinet power control bus is plugged into one of these connectors, the keyswitch will turn on the whole cabinet as well as the computer. The other three-pin Mate-N-Lok is provided for daisy-chaining in the cabinet power control system. The third section of the keyswitch is for Panel Lock and is described in Chapter 4.

The transformer is rated for 47-63 Hz and is equipped with two windings that are connected by the power control in parallel for 115V operation and in series for 230V. The fans are connected across half of the primary so that they are always provided with 115V nominal. There is an electrostatic shield between primary and secondary of the transformer.

The power control circuit breaker contains a single-pole thermal circuit breaker that protects against input overload and is reset by pressing a button on the rear of the computer.

The thermostat is mounted on the power supply heat sink. If the heat sink temperature rises to about 100°C, the thermostat will open one side of the primary circuit and de-energize the power supply. It will automatically reset at about 64°C.

15.3 DC REGULATOR MODULE OPERATION

The discussion of the DC Regulator Module circuits in this manual is directed to the module designated 5409728-0-0, rather than the earlier module designated 5409728-YA-0. A block diagram of this module is shown in Figure 15-4. The center tapped output of the power transformer is applied to positive and negative rectifier and filter circuits. The rectifier circuits produce +28V and -28V nominal raw dc voltages which are unregulated but well filtered by the input storage capacitors.

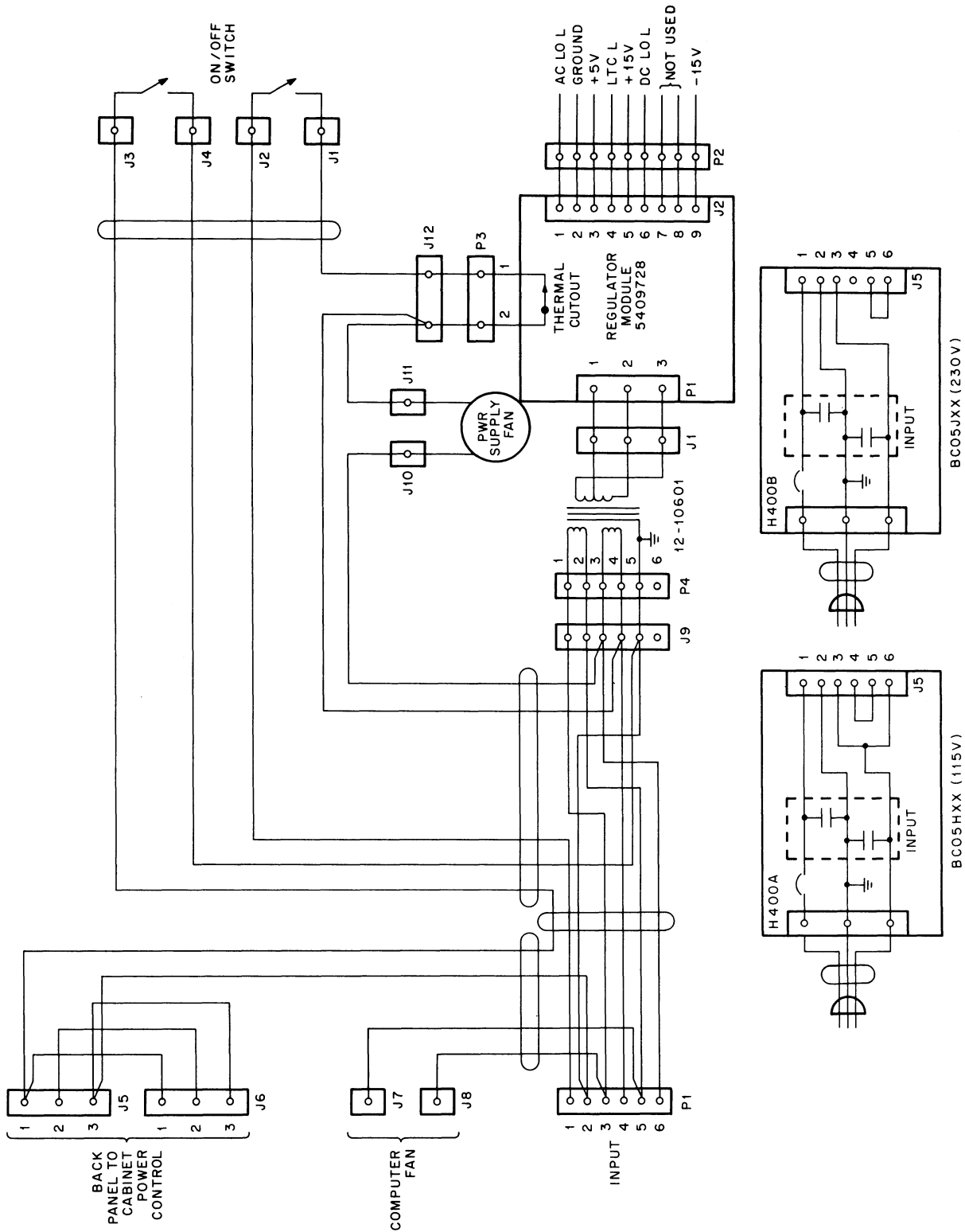

11-1045

Figure 15-1 Detailed AC Interconnection Diagram

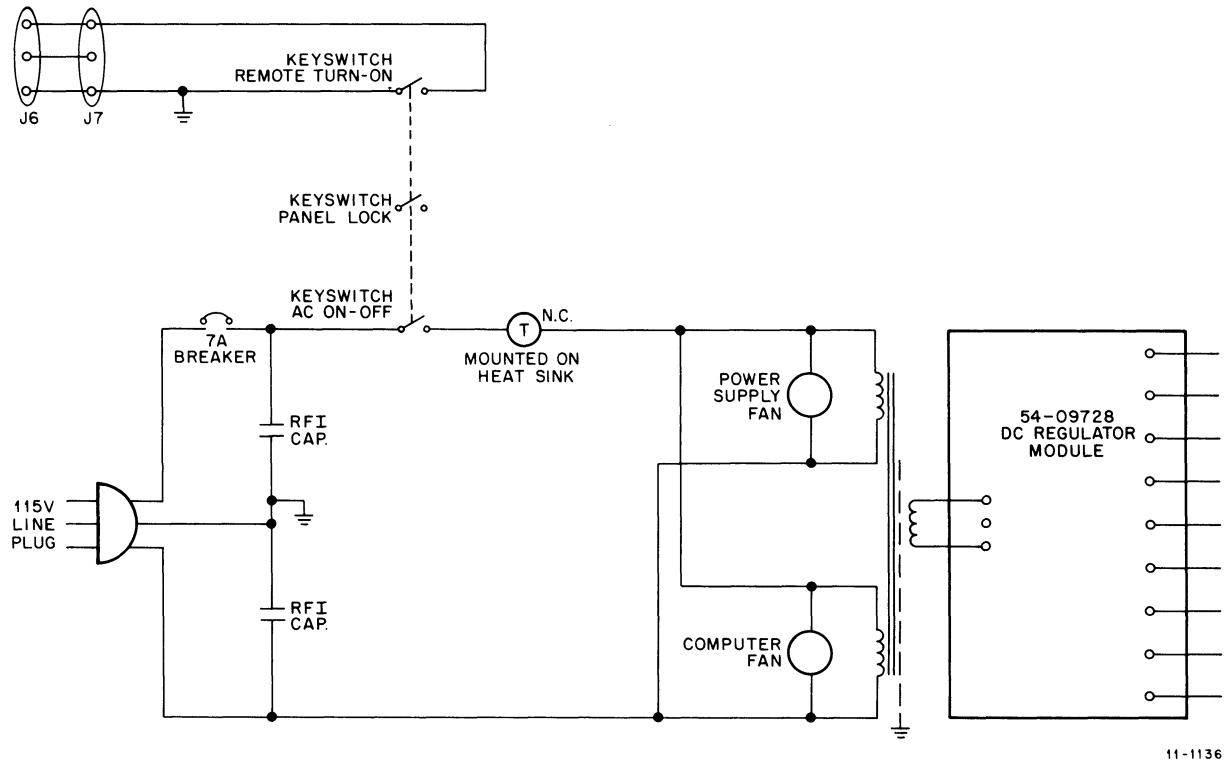

Figure 15-2 115V Connections – Simplified Schematic Diagram

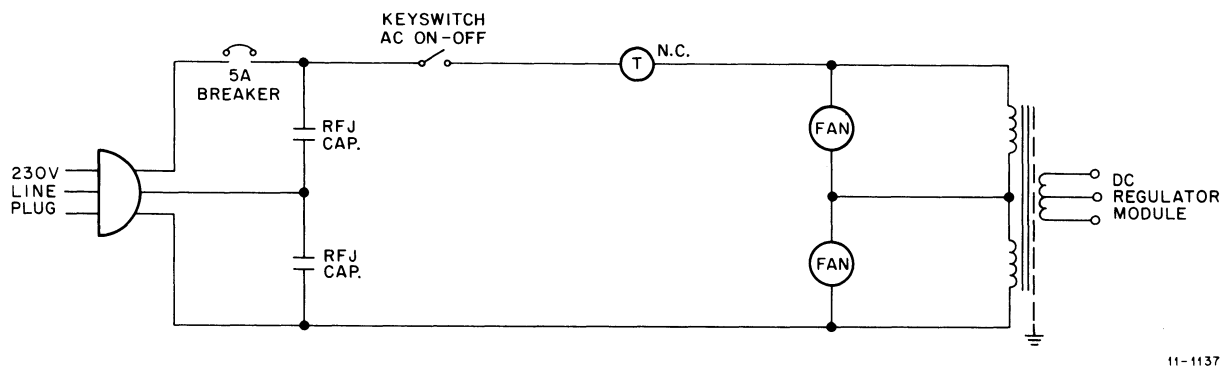
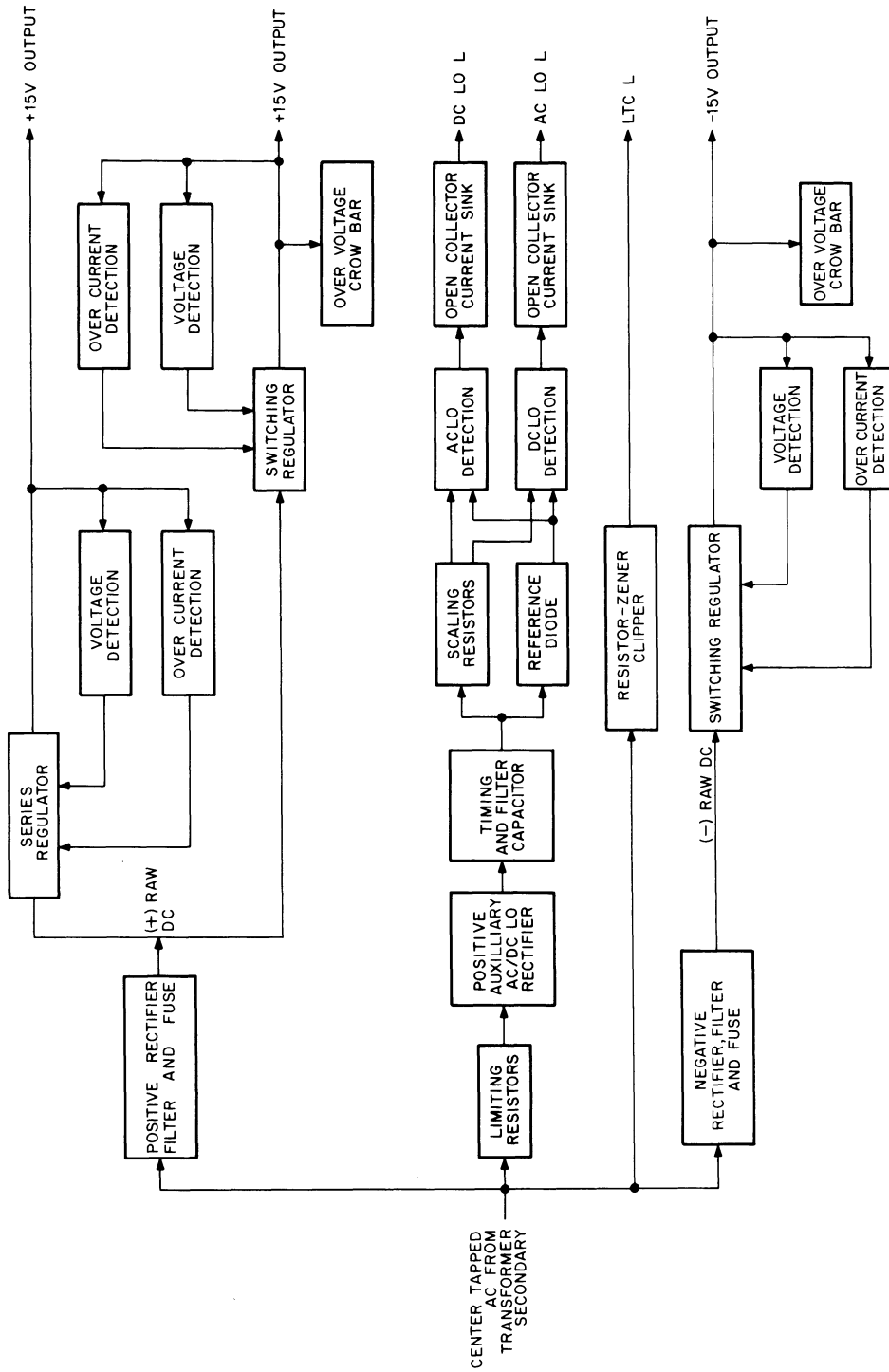

Figure 15-3 230V Connection Diagram



11-1046

Figure 15-4 Regulator Module Block Diagram

The +28V dc is used by an efficient switching regulator circuit to produce the +5V dc output. Provisions for overcurrent detection are incorporated in the regulator circuit so that excess current is limited when there is a malfunction in the load. The +5V output is also protected against overvoltage by a crowbar circuit which limits the output to under 7V; before the output gets to this value the crowbar circuit blows the fuse in the output circuit of the rectifier.

The -28V dc is used by the -15V circuit, which is similar in operation to the +5V regulator circuit. The -15V crowbar circuit limits the output to 22V.

The LTC L Real-Time Clock synchronizing signal is generated by a simple Zener clipper that is fed from the transformer secondary.

The BUS AC LO L and BUS DC LO L signals are used to warn the Unibus of imminent power failure. Circuits on the regulator module detect the transformer secondary voltage and generate two timed TTL-compatible open-collector signals that are used for power fail functions by devices on the Unibus.

15.3.1 Generation of \pm Raw DC

As stated in the previous paragraph, the centertapped transformer secondary voltage is rectified and filtered prior to being fed to the three dc regulators.

The circuitry involved is shown in Figure 15-5. The bridge rectifier D14 is mounted on the heat sink and the input capacitors C1 and C2 are mounted on the bottom of the regulator module. These capacitors filter the input dc and are large enough to provide at least 25-ms storage when the input power is shut off or fails.

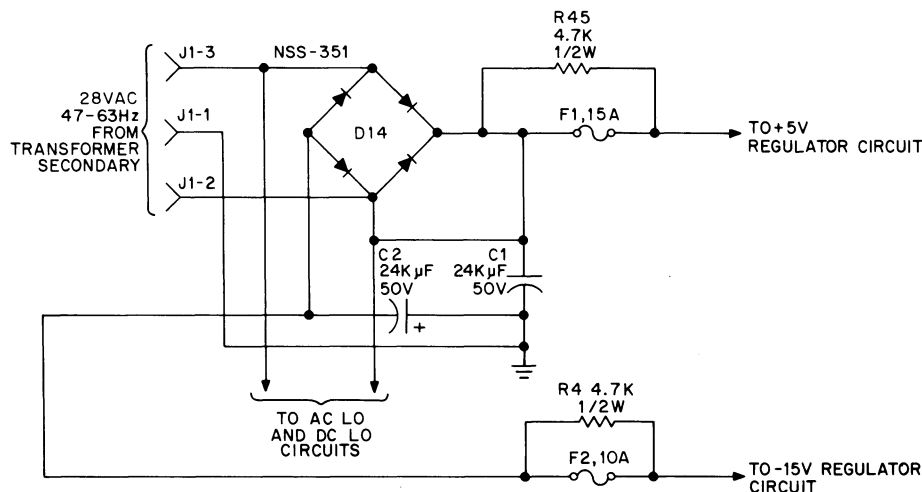

11-1177

Figure 15-5 Rectifier and LTC L Circuits

A fuse is used on each output to protect the regulator and load during faults. The fuses will not normally blow when a regulator output is shorted because the three outputs are electronically overcurrent protected. However, the appropriate fuse will blow in case of +5V or -15V overvoltage crowbar or in case of failure in one of the overcurrent circuits.

The resistor across each fuse provides a slow (100 - 150 seconds) discharge of C1 or C2 after the power is turned off in case a fuse blows. The capacitors are placed ahead of the fuse to limit the energy in any fault and thus better protect the outputs.

15.3.2 LTC L Circuit

The LTC L Real-Time Clock synchronizing signal (Figure 15-3) is generated by a Zener clipper circuit. The output waveform is a square (clipped sine) wave at line frequency. For one polarity of output sine wave, D13 clips at about +3.9V and in the other polarity D13 clips at its forward voltage of -0.7V.

15.3.3 BUS AC LO L and BUS DC LO L Circuits

The circuitry shown in Figure 15-6 is employed to generate the timed Unibus power status signals specified in Table 14-2. These are used for power fail functions. The transformer secondary voltage is rectified by D1 and D2 and filtered by C9 and R1, R14.

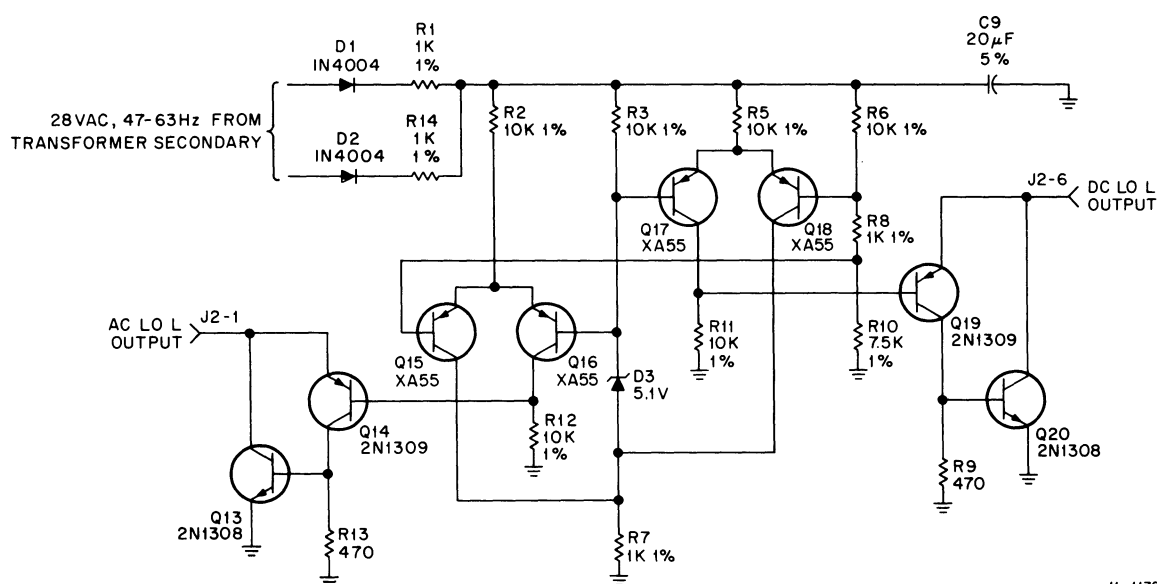

Figure 15-6 BUS AC LO and BUS DC LO Circuits

Circuit parameters are chosen so that the voltage across C9 will rise slower than the three regulated output voltages on power-up, and will decay faster than the three regulated output voltages on power-down.

Two differential amplifier circuits are used to detect power status: Q17, Q18 is used to generate BUS DC LO L; and Q15, Q16 is used to generate BUS AC LO L. The differential amplifiers share a common reference Zener diode D3, which is fed approximately 1 mA by R3.

As C9 charges subsequent to power-up, first Q17, Q18, and then Q15, Q16 change state; the reverse is true during power-down. When C9 starts to charge, Q17 and Q16 are on and Q15 and Q18 are not conducting. As C9 charges further, Q18 starts to conduct into R7 and raises the voltage on cathode D3. This acts as positive feedback and snaps Q17 off and Q18 on more solidly. A few milliseconds later, the voltage across C9 has risen sufficiently for the same process to take place in differential amplifier Q15, Q16. The status of each differential amplifier is followed by the germanium transistor open-collector output stages Q19, Q20 for BUS DC LO L, and Q13, Q14 for BUS AC LO L. These stages clamp the Unibus at about +0.4V until the differential amplifier circuits sequentially signal them across R11 and R12 that power is up. The outputs then rise to about +5V as dictated by the Unibus loading and pull-up termination resistors.

The sequence is as follows:

- power-up → then BUS DC LO L = 0 → then BUS AC LO L = 0
 0 = High (+3V)
- power-down → BUS AC LO L = 1 → BUS DC LO L = 1
 1 = low (+0.4V)

Any time that BUS DC LO L or BUS AC LO L go low, there is sufficient storage in capacitors C1 and C2 to maintain output voltage long enough to permit the power fail circuit to operate. The open collector stages are designed to clamp the Unibus to 0.4V maximum, even when there is no ac input to the regulator. They are inherently biased on by R11 and R12 until the differential amplifiers signal that power is OK.

15.3.4 +15V Regulator Circuit

The +15V regulator shown in Figure 15-7 is a simple series regulator. The pass transistor Q1 is a high-gain power Darlington and is mounted on the heat sink. Base drive current is supplied to Q1 via R38. Q3 acts to limit the value of this current to the required value by shunting it away from the Q1 base. Q4, the voltage detector amplifier, biases on Q3 and thus limits current in Q1. The +15V output voltage is sampled on the viewing chain R34, 35, 36 and compared to the voltage across reference Zener D8, which is fed by R37. If the output should try to increase from the regulated value, the emitter of Q4 is made more negative (relatively) than its base and conduction through Q4 increases. This increases the conduction through Q3 and causes Q1 to shut down sufficiently to restore the output voltage to the regulated value. Ambient temperature compensation of the voltage detector is essentially flat since D8 has a +2 mV/°C temperature coefficient and the base emitter junction of Q4 has a -2 mV/°C temperature coefficient.

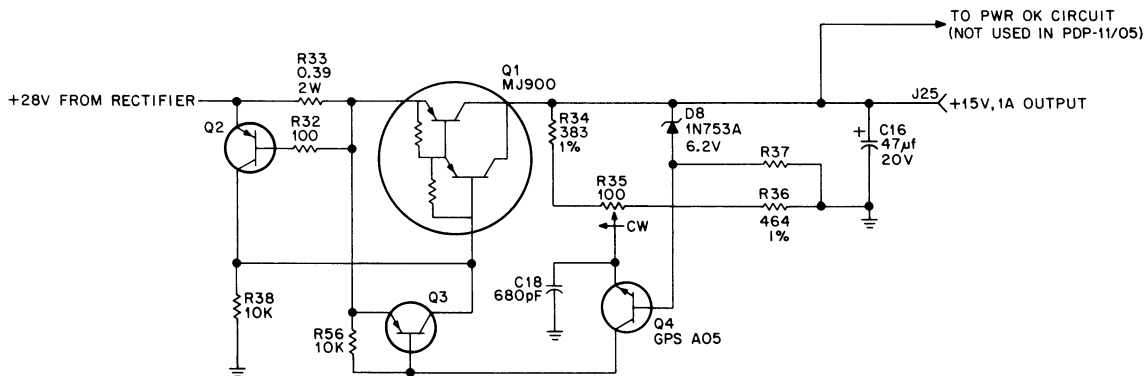

11-0968

Figure 15-7 +15V Regulator Circuit

R35 acts as the +15V voltage adjustment potentiometer. C18 is a high frequency stabilization capacitor. Q2 is the overload detector; when the output current reaches 1.5A nominal, the voltage across R33 is sufficient to cause Q2 to conduct. This removes base drive from Q1 and causes the regulator to current limit.

15.3.5 +5V Regulator Circuit

The +5V regulator is similar to the +15V regulator in that the sampled output voltage is compared to the voltage across a reference Zener by a voltage detector transistor, which in turn controls the drivers for the main pass transistor. The +5V regulator circuit is shown in Figure 15-8. An over-current circuit is likewise employed.

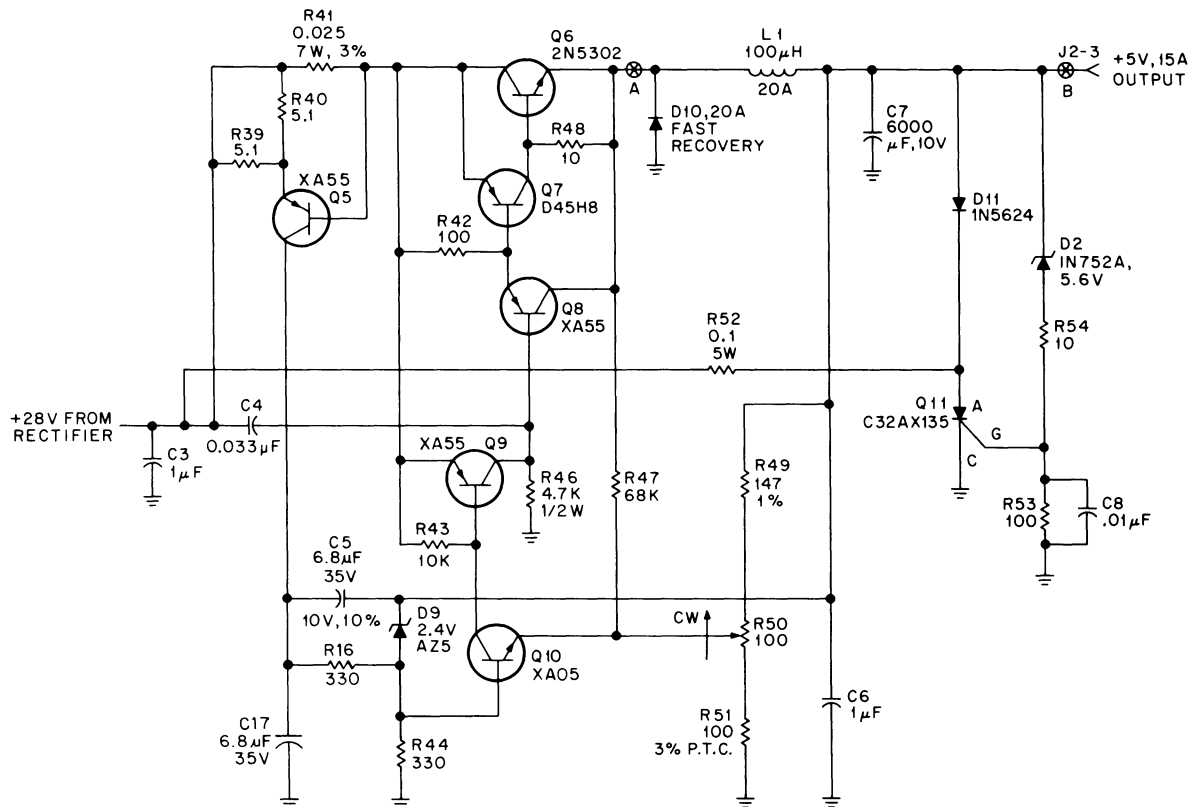

Figure 15-8 +5V Regulator Circuit

The viewing chain consists of R49, 50, 51 and the reference Zener is D9, which is fed by R44. Q10 is the detector amplifier. The pass transistor Q6 and first stage driver Q7 are mounted on the heat sink. The predriver Q8 is turned on by R46. The current is diverted from the base of Q8 by off-driver Q9, which is controlled by Q10. The +15V and +5V regulators are similar in operation; i.e., a tendency for the output voltage to rise results in more conduction through Q10 and resultant limiting of conduction through Q6.

Here the similarity ends. The +5V circuit is a regulator that operates in the switching mode for increased efficiency. To get the regulator to switch, positive feedback is applied to the voltage detector input via R47. Thus the whole regulator acts as a power Schmitt trigger and is either completely turned on or turned off, depending on whether the output voltage is too high or too low. When Q6 is on, it supplies current through filter choke L1 to the output smoothing capacitor C7 and the load. When Q6 is off, the L1 current decays through commutating diode D10, which becomes forward biased by the back emf of L1. The waveform across D10 is a 30V nominal rectangular pulse train. The filtered output across C7 is thus +5 Vdc with about a 200-mV peak-to-peak 10-kHz nominal sawtooth of super-imposed ripple. At the crest of the ripple, Q6 turns off and at the valley Q6 turns on. This switching mode of operation limits the dissipation in the circuit to the saturated forward losses of Q6 and D10 and the switching losses of Q6. The resultant high efficiency allows the heat sink to be small and the number 8 power semiconductors to be few.

R50 is the voltage adjustment potentiometer. R51 is a positive temperature coefficient wire-wound resistor that compensates for the fact that the Q10 base-emitter junction and the reference diode D9 both have negative voltage temperature coefficients. Q5 current, limited by R39, 40, detects the overcurrent signal generated across resistor R41, which is in series with the Q6 collector.

Output fault current is limited to a safe value because conduction of Q5 makes the reference voltage across D9 decrease to zero. This causes Q10 to conduct and shuts down the regulator. C5 is an averaging capacitor, which is necessary in the circuit because the current through R41 is pulsating.

High frequency bypass capacitors are used on input and output of the regulator, C3 and C6, respectively. C4 is used to slow down the turn-on of Q6 to allow D10 to recover from the on state without a large reverse current spike.

In the event a malfunction causes the output voltage to increase beyond about 6.8V nominal, Zener diode D2 will conduct and fire silicon-controlled rectifier Q11. This will crowbar the output voltage to a low value through D11 and will blow fuse F1 in the rectifier circuit through R52.

15.3.6 -15V Regulator Circuit

The -15V regulator circuit is shown in Figure 15-9. It is essentially the complement of the +5V regulator circuit and differs only in minor detail.

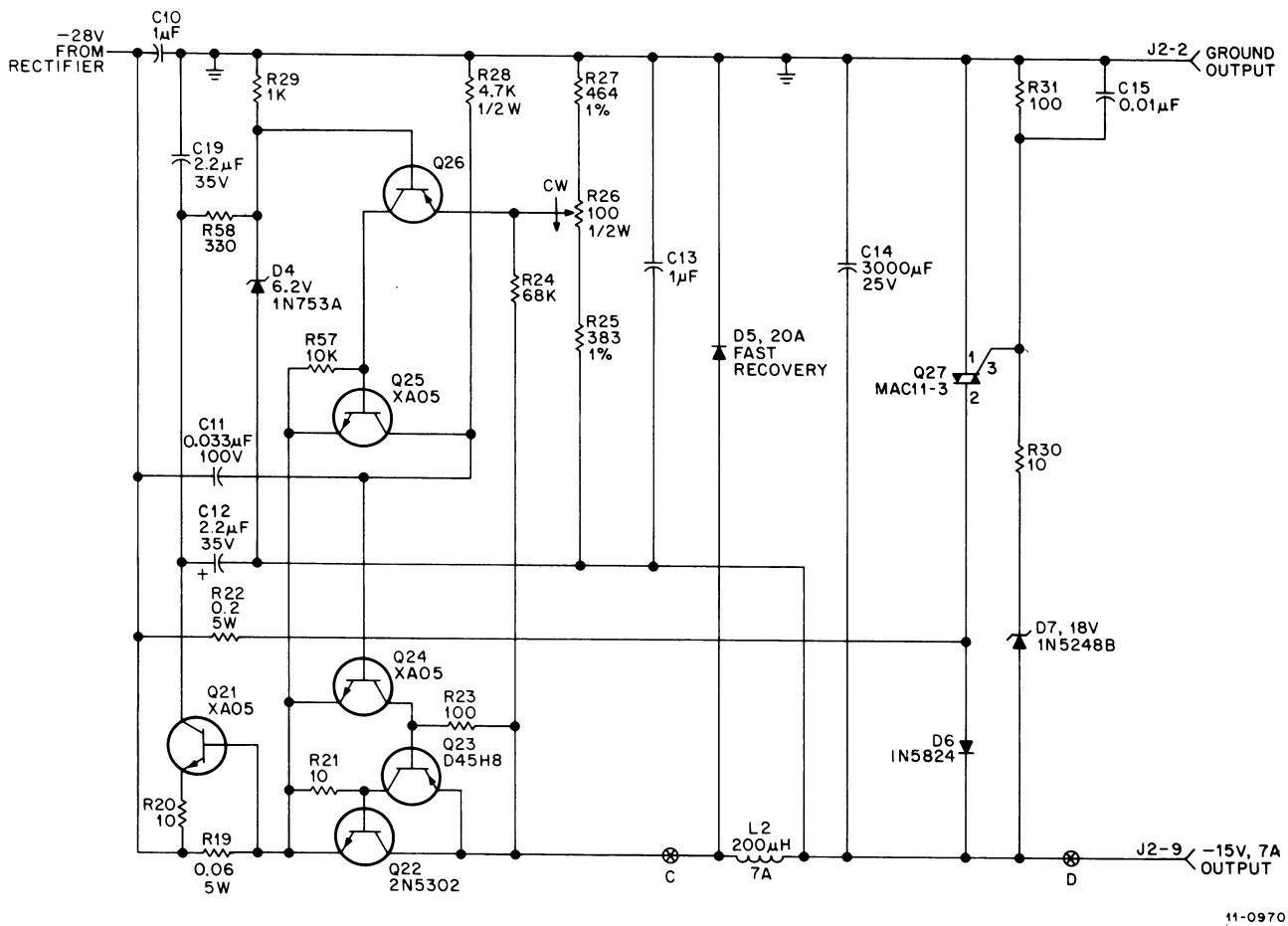

Figure 15-9 -15V Regulator Circuit

The crowbar device is a Triac Q27 instead of an SCR. No temperature compensating resistor is required because Q26 and D4 track each other, as in the +15V regulator (Paragraph 15.3.4). The detailed interconnection of the drivers and the circuit values are different. The -15V output voltage is adjusted by potentiometer R26.

CHAPTER 16

POWER SUPPLY MAINTENANCE

16.1 INTRODUCTION

Information is provided in this chapter to maintain the power supply. This consists of adjustments, circuit waveforms, troubleshooting, and parts identification. The adjustments consist of three output potentiometers. The circuit waveforms provide a guide to proper operation at various places in the circuit. The troubleshooting section provides rules, hints, and a troubleshooting chart as a maintenance aid in isolating power supply malfunctions. Finally, the parts identification section provides a directive to obtaining parts information for the entire power supply unit through a parts location directory to the mechanical engineering drawings in the *Engineering Drawing Manual*.

16.2 ADJUSTMENTS

Three adjustments to the power supply adjust the three dc output voltages: +15V, +5V, and -15V. A small screwdriver is all that is required. Clockwise adjustment of any of the potentiometers increases voltage, and the potentiometers are located on the top side of the dc regulator module. The potentiometer designations are:

- a. R35 – +15V
- b. R50 – +5V
- c. R26 – -15V

In performing any of these adjustments note the following:

CAUTION

1. **Do not adjust voltages beyond their 105 percent rating and adjust slowly in order to avoid overvoltage crowbar, which will blow dc output fuses.**
2. **Do use a calibrated voltmeter; preferably a digital voltmeter. Voltages should be adjusted to their center values: +15.0, +5.0, and -15.0, all under load at the dc cable termination on the system unit.**

16.3 CIRCUIT WAVEFORMS

The two basic regulator circuits used on the dc regulator module generate +5V and -15V. Figure 16-1 shows six waveforms of the +5V regulator circuit taken at two points (A and B) in the circuit (Figure 14-6). Waveforms a, b, and c are taken at point A, which is the +5V circuit, Q6 transistor output. Waveforms d, e, and f are taken at point B, which is +5V power supply output (J2-3). Figure 16-1 also indicates the load conditions and time scales for each waveform. Figure 16-2 shows six waveforms of the -15V regulator circuit taken at two points (C and D) in the circuit (Figure 14-7). Waveforms a, b, and c are taken at point C, which is the -15V power supply output (J2-9). The load conditions and time scales of the respective waveforms are indicated in Figure 16-2. These waveforms were taken on a Tektronix Model 453 Oscilloscope. All waveforms are with respect to J2-2, power common.

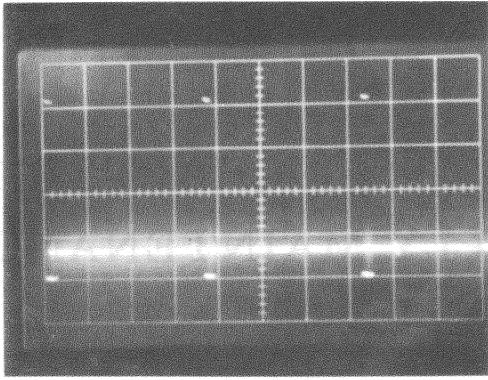

a) Point A, No load,
2 ms/div, and
10V/div.

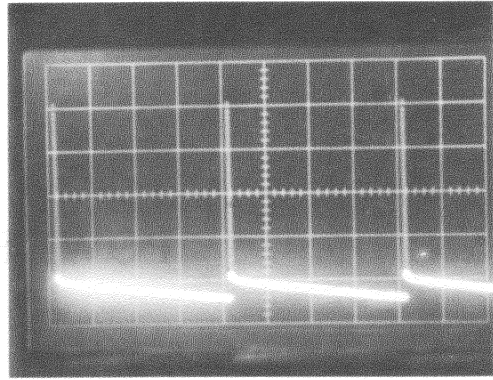

d) Point B, No load,
2 ms/div, and
50 mV/div.

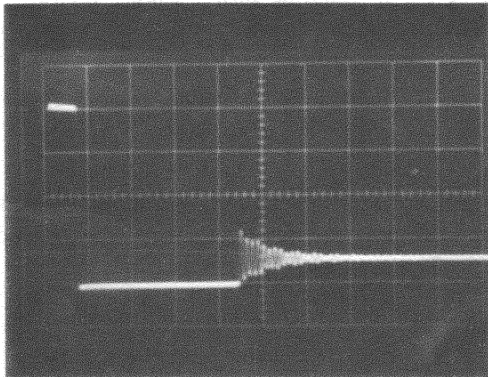

b) Point A, No load,
20 μ s/div, and
10V/div.

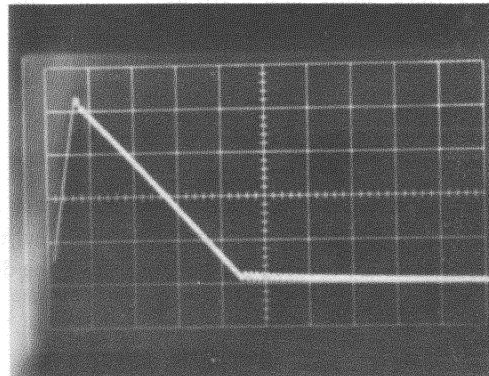

e) Point B, No load,
20 μ s/div, and
50 mV/div.

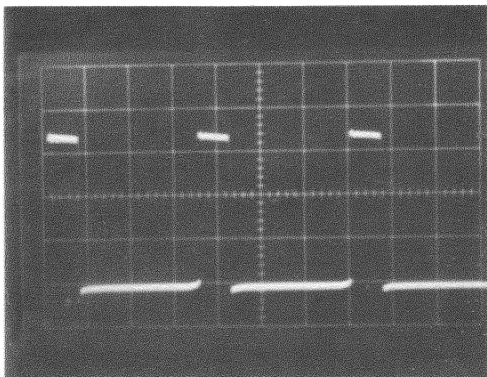

c) Point A, 20A load,
20 μ s/div, and
10V/div.

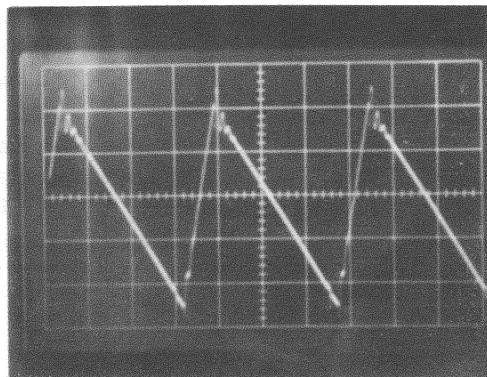

f) Point B, 20A load,
 μ s/div, and
50 mV/div.

Figure 16-1 +5V Regulator Circuit Waveforms

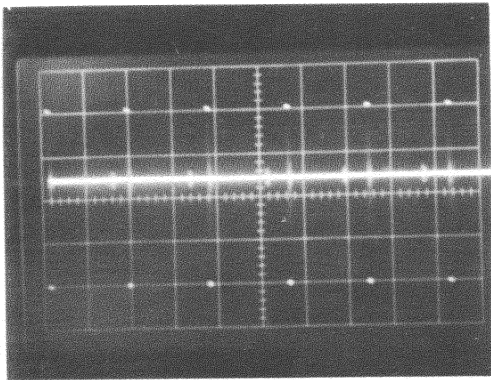

a) Point C, No load,
5 ms/div, and
10V/div.

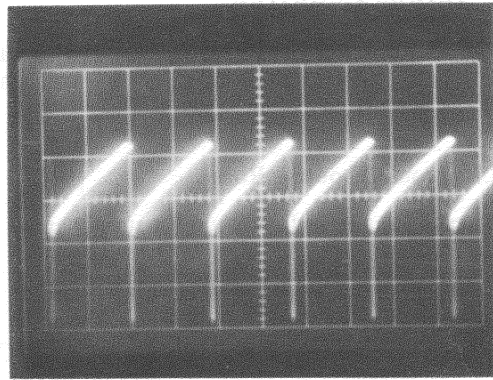

d) Point D, No load,
5 ms/div, and
50 mV/div.

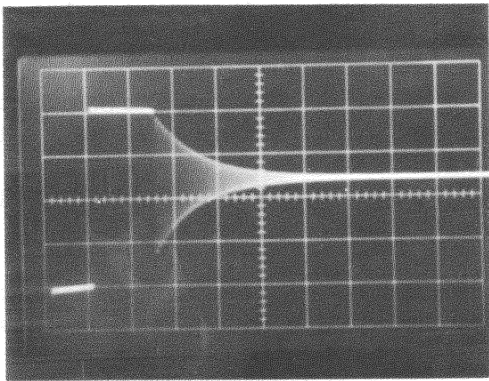

b) Point C, No load,
50 μ s/div, and
10V/div.

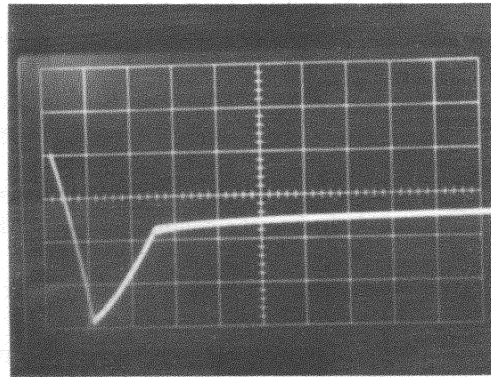

e) Point D, No load,
50 μ s/div, and
50 mV/div.

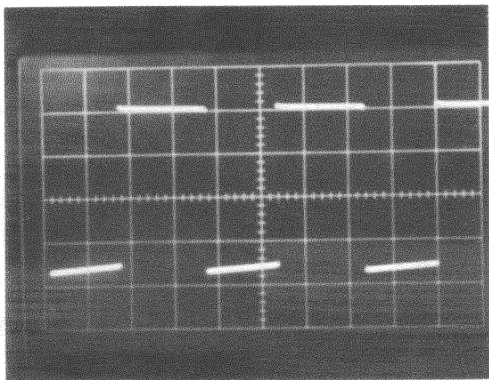

c) Point C, 5A load,
50 μ s/div, and
10V/div.

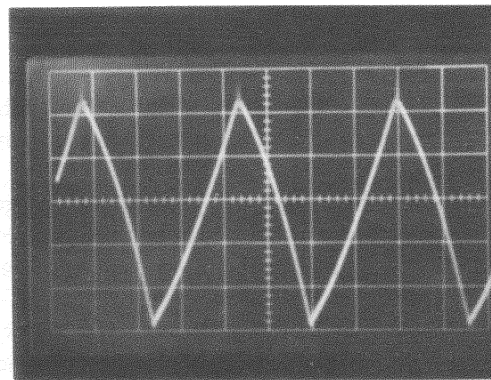

f) Point D, 5A load,
50 μ s/div, and
50 mV/div.

Figure 16-2 -15V Regulator Circuit Waveforms

16.4 TROUBLESHOOTING

Troubleshooting information for the power supply consists of troubleshooting rules, hints, and a troubleshooting chart. This information provides a maintenance aid to isolating power supply malfunctions (drawing D-CS-5409728-0-1).

16.4.1 Troubleshooting Rules

Troubleshooting rules for the power supply are as follows:

- a. Make certain that power is turned off and unplugged before servicing the power supply.
- b. Ensure that input capacitors C1 and C2 are discharged before servicing the power supply. A 10 to 100 Ω , 10W resistor can be used to hasten the discharge of the capacitors. (Be sure power is off.)
- c. The dc regulator module is not internally grounded to the chassis; therefore, shorts to ground can be located after disconnecting the dc output cable to the system unit.
- d. The dc output fuses F1 and F2 can be replaced without removing the dc regulator module. Before unsoldering fuses, observe cautions described in Steps a and b.
- e. For proper operation, all hardware must be secured tightly to about 12 inch-pounds (i.e., capacitors, chokes, semiconductors). All hardware should be replaced with identical hardware replacement parts.
- f. The dc regulator module may be removed from the top of the power chassis assembly while the latter is still bolted to the computer chassis. The dc regulator module is held in place by six screws.
- g. When replacing power semiconductor components that are secured to the heat sink, apply a thin coat of Wakefield #128 compound or Dow Silicon Grease to the heat sink contact side (bottom) of the semiconductor. Insulating wafers are not required.

16.4.2 Troubleshooting Hints

CAUTION
Unplug computer before servicing.

The most likely source of power supply malfunction is the dc regulator module. A quick remedy for a malfunction may be to replace this entire module. The problem, however, could be a short in the system unit or possibly a defective component or other problem in the ac input circuit.

The +5V and -15V regulators contain overvoltage detection circuitry. If R50 or R26 are adjusted too far clockwise, the corresponding crowbar circuit will trip and blow fuses. To correct this condition: adjust the potentiometer fully counterclockwise, replace the blown fuse, and re-adjust per Paragraph 16.2.

Make a visual examination of the circuitry. Check for burnt resistors, cracked transistors, burnt printed circuit board etch, oil leaking from capacitors, and loose connections. A visual check can be a quick method of locating the cause of a malfunction.

16.4.3 Troubleshooting Chart

In checking the various areas of the power supply, the rules listed in Paragraph 16.4.1 should be followed. The waveforms referenced in Paragraph 16.3 provide a comparison for the troubleshooting readings. Table 16-1 provides the dc regulator troubleshooting chart.

**Table 16-1
Troubleshooting Chart**

Problem	Cause
No +5V and +15V output	F1 opened* D14 or transformer opened* +5V adjusted too high*
+5V Output Too Low	Q5, D9, Q10, Q9, Q11, D12, or D10 Shorted C5 or C7 shorted R49, R50, R46, or R44 opened Q6, Q7, Q8, or D11 shorted A9, Q10, or D9 opened* R51, or R50 opened
+15V Output Too High	Q1 shorted E8 opened R35 or R36 opened
No -15V Output	F2 opened D14 or transformer opened
-15V Output Too Low	-15V adjusted too high* Q25, D4, Q26, Q21, Q27, D7 or D5 shorted C14 or C12 shorted R22, R26, R25, or R29 opened Q22, Q23, Q24, or D6 shorted Q25, Q26, or D4 opened
BUS AC LO L Will Not Go High	Q13, Q14, or Q15 shorted Q16 or D3 opened R7, R3, R6, or R8 opened C9 shorted
BUS AC LO L Will Not Go Low and/or acts erratically on power-on/power-off	Q13, Q14, or Q16 opened Q15 or D3 shorted R12, R13, R7, or R10 opened
BUS DC LO L Will Not Go High	Q19, Q20, or Q18 shorted Q17 or D3 opened R7, R2, or R6 opened C9 shorted
BUS DC LO L Will Not Go Low	Q19, Q20, or Q17 opened Q17 or D3 opened R7, R3, or R6 opened C9 shorted

*These causes make the crowbar fire, which in turn, blows the appropriate fuse.

**Table 16-1 (Cont)
Troubleshooting Chart**

Problem	Cause
BUS DC LO L Will Not Go Low and/or acts erratically on power-on/power-off	Q19, Q20, or Q17 opened Q18 or D3 shorted R9, R10, R11, or R8 opened
No LTC L Signal	R55 opened D13 shorted
LTC L Going Too High	D13 opened

16.5 PARTS IDENTIFICATION

Parts identification for the power supply is provided in the *Engineering Drawing Manual*. This includes the assembly drawings with associated parts lists, which list the respective unit parts, their part designation, and their DEC part numbers. These drawings and the respective drawing numbers are as follows:

- a. Power Supply Chassis: E-1A-5309816-0-0
- b. Power Control Board 115V: C-IA-5409824-0-0
230V: C-IA-5409825-0-0
- c. DC Regulator Module: E-IA-5409728-0-0
D-CS-5409728-0-1 (schematic)
- d. Power Supply Assembly and Fan: D-AD-7003731-0-0
- e. AC Input Box Assembly: D-UA-H400-0-0
- f. Line Set 115 Vac 7A: C-UA-BC05H-0-0
230 Vac 5A: C-UA-BC05J-0-0

APPENDIX A

INTEGRATED CIRCUIT DESCRIPTIONS

A.1 INTRODUCTION

The MSI and LSI integrated circuits (ICs) which are shown in the engineering drawings are discussed in the following paragraphs. The descriptions include a pin location diagram, simplified logic diagram, and truth table. These descriptions are intended as maintenance aids for troubleshooting to the IC level. Table A-1 lists the ICs by part number, name, and respective paragraph number.

Table A-1
Integrated Circuits

Manufacturer Part Number	DEC Part Number	Name	Para.
8266	19-09934	2-Input, 4-Bit Digital Multiplexer	A.2
7413	19-09989	Dual NAND Schmitt Triggers	A.3
7473	19-05587	Dual J-K Master-Slave Flip-Flops	A.4
7474	19-05547	Dual D-Type, Edge-Triggered Flip-Flops	A.5
7475	19-09050	4-Bit Bistable Latch	A.6
7489	19-10396	64-Bit Read/Write Memory	A.7
74121	19-10230	Monostable Multivibrator	A.8
74150	19-10153	Data Selector Multiplexer	A.9
74153	19-09927	Dual 4-Line-to-1-Line Data Selectors/Multiplexers	A.10
74154	19-09701	4-Line-to-16-Line Decoders/Demultiplexers	A.11

Table A-1 (Cont)
Integrated Circuits

Manufacturer Part Number	DEC Part Number	Name	Para
74157/74S158	19-10655/ 19-10656	Quadruple 2-Line-to-1-Line Multiplexer	A.12
74174/74175	19-10652/ 19-10651	D-Type Flip-Flops, Hex/Quad with Clear	A.13
74181	19-09982	Arithmetic Logic Unit/Function Generator (ALU)	A.14
74182	19-10019	Look-Ahead Carry Generator	A.15
74193	19-10018	Synchronous 4-Bit Up/Down Counter (Dual Clock with Clear)	A.16
74194	19-10623	4-Bit Bidirectional Universal Shift Registers	A.17
7528	19-10687	Dual Sense Amplifiers with Preamplifier Test Points	A.18
9602	19-09374	Dual Retriggerable Monostable Multivibrator with Clear	A.19

A.2 8266 2-INPUT, 4-BIT DIGITAL MULTIPLEXER

Truth Table

Select Lines		Output t_n (0,1,2,3)
S_0	S_1	
0	0	B_n
0	1	B_n
1	0	\overline{A}_n
1	1	1

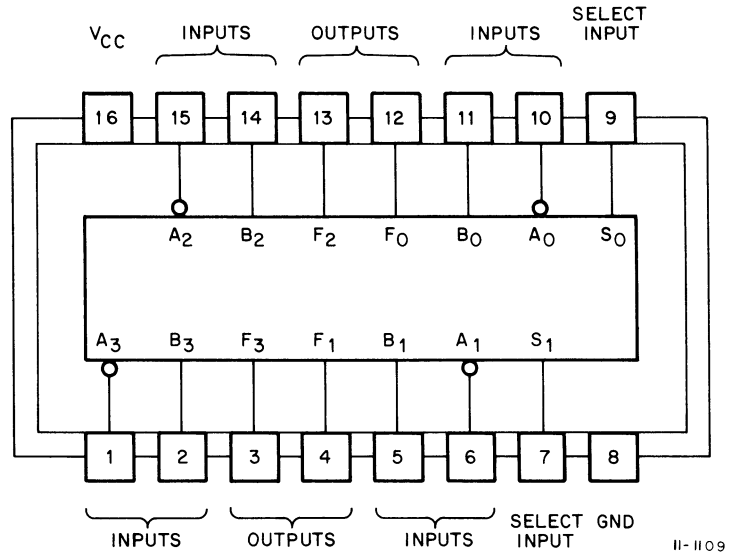

11-1109

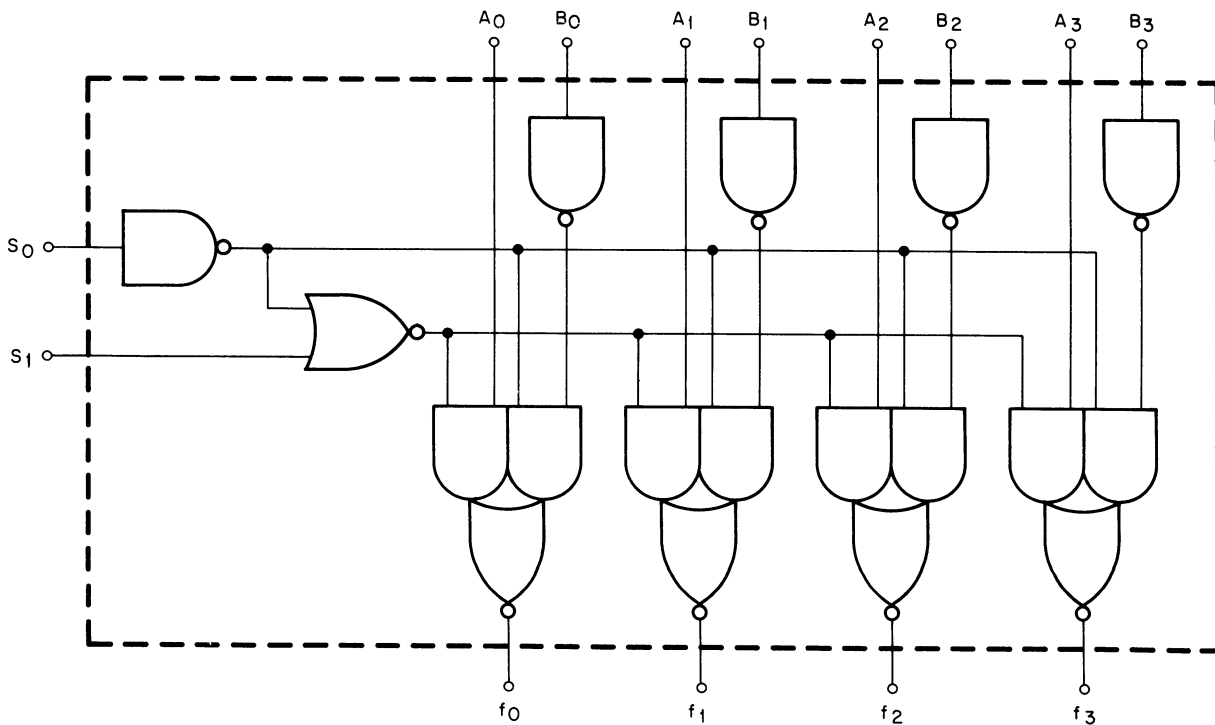

11-0632

A.3 7413 DUAL NAND SCHMITT TRIGGERS

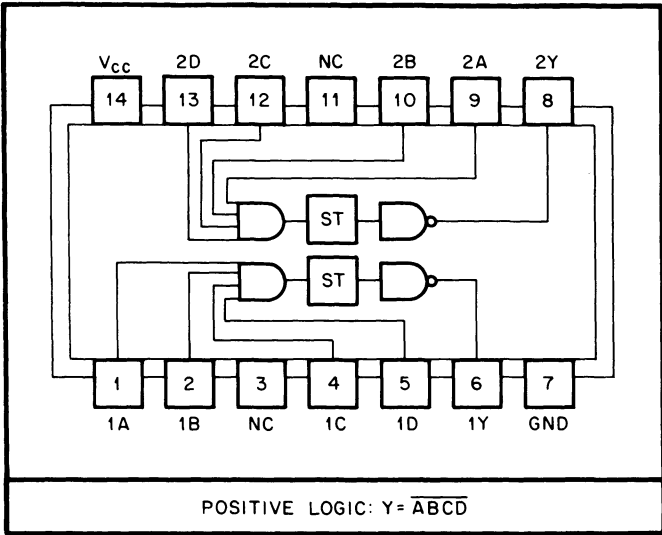

11-1114

A.4 7473 DUAL J-K MASTER-SLAVE FLIP-FLOPS

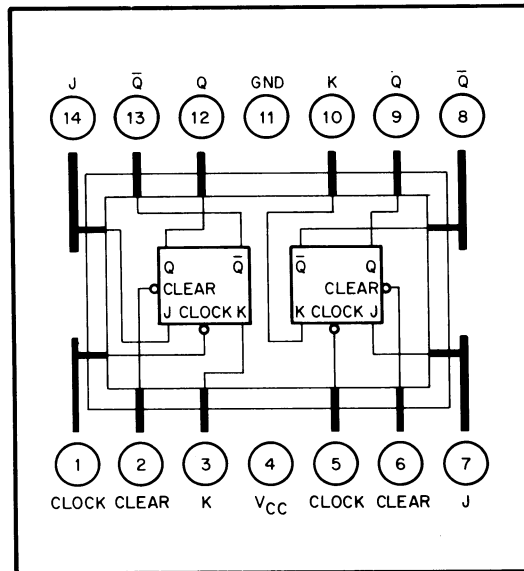

TRUTH TABLE (EACH FLIP-FLOP)		
t_n		t_{n+1}
J	K	Q
0	0	Q_n
0	1	0
1	0	1
1	1	\bar{Q}_n

t_n = Bit time before clock pulse.
 t_{n+1} = Bit time after clock pulse.

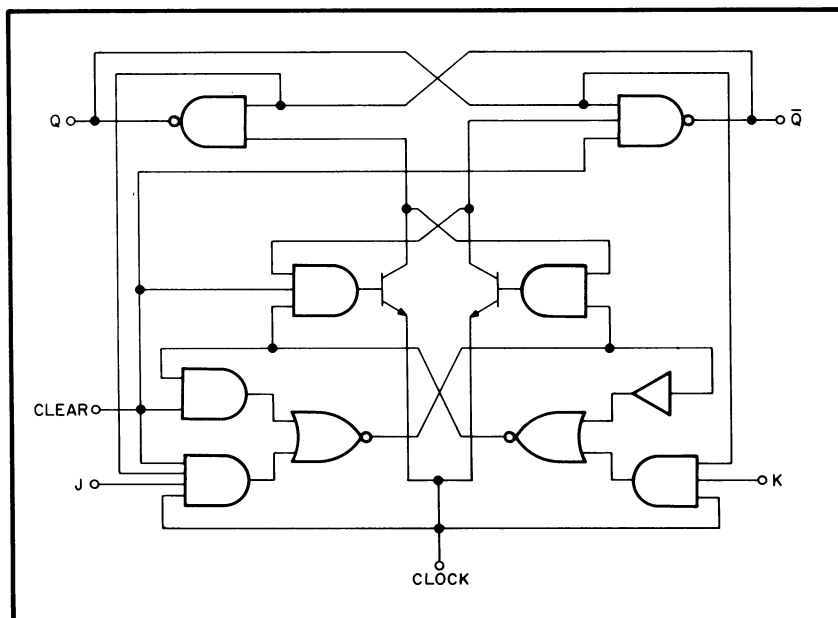

11-1128

A.5 7474 DUAL D-TYPE EDGE-TRIGGERED FLIP-FLOPS

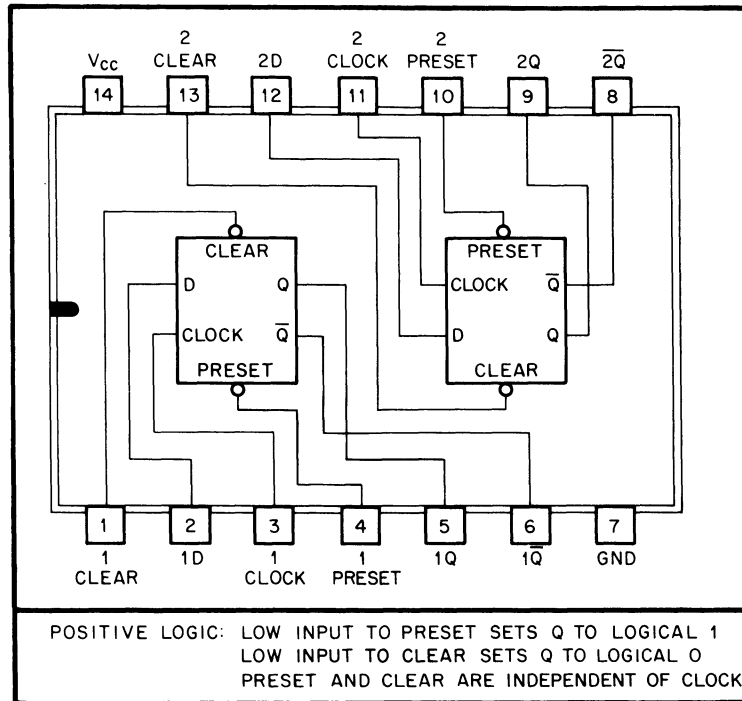

11-0766

Truth Table (Each Flip-Flop)

t_n	t_{n+1}	
	Output Q	Output \bar{Q}
Input D		
0	0	1
1	1	0

- Notes: 1. t_n = bit time before clock pulse.
 2. t_{n+1} = bit time after clock pulse.

A.6 7475 4-BIT BISTABLE LATCH

**Truth Table
(Each Latch)**

t_n	t_{n+1}
D	Q
1	1
0	0

- NOTES:
1. t_n = bit time before clock negative-going transition.
 2. t_{n+1} = bit time after clock negative-going transition.

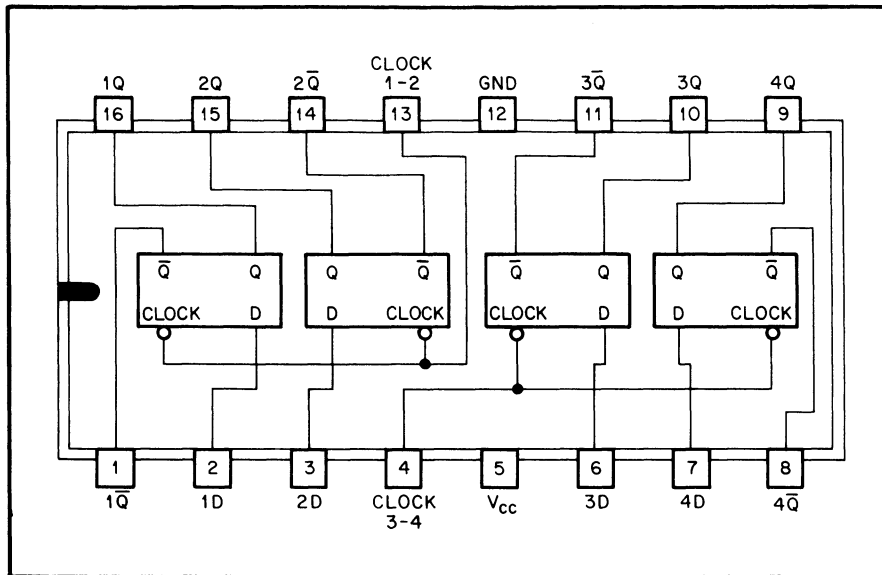

11-0894

A.7 7489 64-BIT READ/WRITE MEMORY

Function Table

ME	WE	Operation	Condition of Outputs
L	L	Write	Complement of Data Inputs
L	H	Read	Complement of Selected Word
H	L	Inhibit Storage	Complement of Data Inputs
H	H	Do Nothing	High

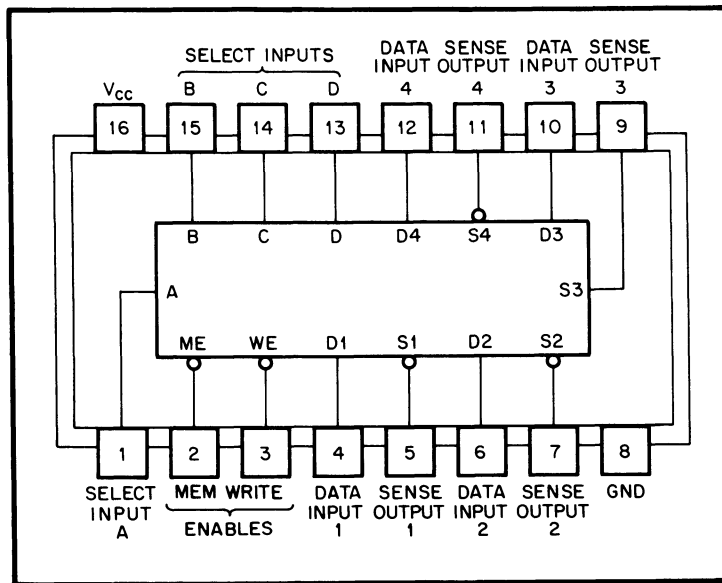

11-1117

A.8 74121 MONOSTABLE MULTIVIBRATOR

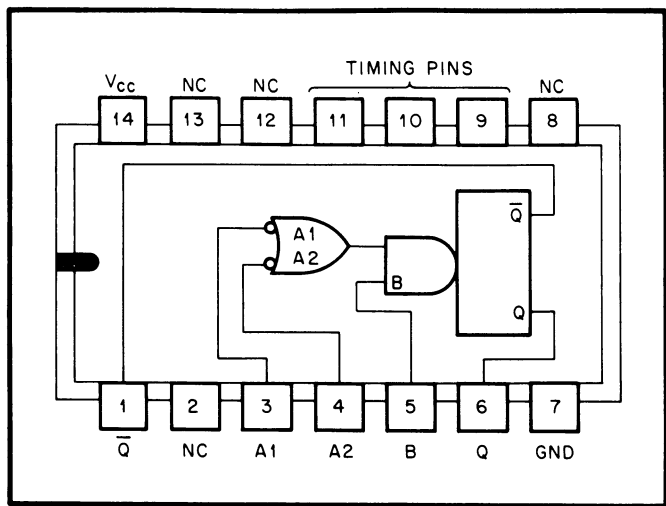

11-1119

TRUTH TABLE

t_n INPUT			t_{n+1} INPUT			OUTPUT
A1	A2	B	A1	A2	B	
1	1	0	1	1	1	INHIBIT
0	X	1	0	X	0	INHIBIT
X	1	0	X	0	0	INHIBIT
0	X	0	0	X	1	ONE SHOT
X	0	0	X	0	1	ONE SHOT
1	1	1	X	0	1	ONE SHOT
1	1	1	0	X	1	ONE SHOT
X	0	0	X	1	0	INHIBIT
0	X	0	1	X	0	INHIBIT
X	0	1	1	1	1	INHIBIT
0	X	1	1	1	1	INHIBIT
1	1	0	X	0	0	INHIBIT
1	1	0	0	X	0	INHIBIT

1 = $V_{in}(1) \geq 2V$

0 = $V_{in}(0) \leq 0.8V$

A.9 74150 DATA SELECTOR MULTIPLEXER

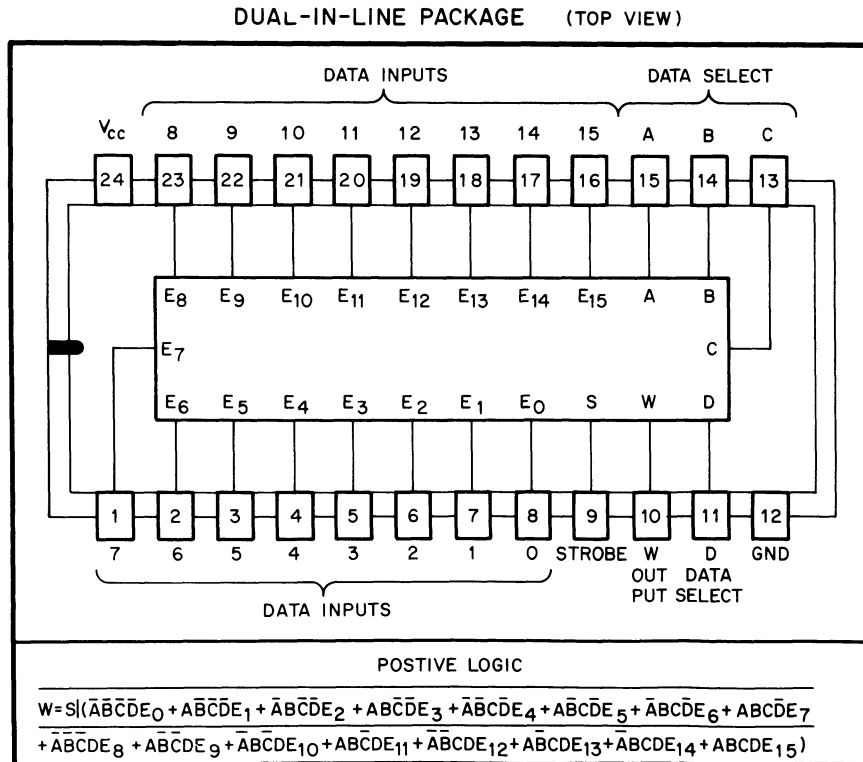

12-0324

TRUTH TABLE

Inputs																					Output
D	C	B	A	Strobe	E ₀	E ₁	E ₂	E ₃	E ₄	E ₅	E ₆	E ₇	E ₈	E ₉	E ₁₀	E ₁₁	E ₁₂	E ₁₃	E ₁₄	E ₁₅	W
x	x	x	x	1	x	x	x	x	x	x	x	x	x	x	x	x	x	x	x	x	1
0	0	0	0	0	0	x	x	x	x	x	x	x	x	x	x	x	x	x	x	x	1
0	0	0	0	0	1	x	x	x	x	x	x	x	x	x	x	x	x	x	x	x	0
0	0	0	1	0	x	0	x	x	x	x	x	x	x	x	x	x	x	x	x	x	1
0	0	0	1	0	x	1	x	x	x	x	x	x	x	x	x	x	x	x	x	x	0
0	0	1	0	0	x	x	0	x	x	x	x	x	x	x	x	x	x	x	x	x	1
0	0	1	0	0	x	x	1	x	x	x	x	x	x	x	x	x	x	x	x	x	0
0	0	1	1	0	x	x	x	0	x	x	x	x	x	x	x	x	x	x	x	x	1
0	0	1	1	0	x	x	x	1	x	x	x	x	x	x	x	x	x	x	x	x	0
0	1	0	0	0	x	x	x	x	0	x	x	x	x	x	x	x	x	x	x	x	1
0	1	0	0	0	x	x	x	x	1	x	x	x	x	x	x	x	x	x	x	x	0
0	1	0	1	0	x	x	x	x	x	0	x	x	x	x	x	x	x	x	x	x	1
0	1	0	1	0	x	x	x	x	x	1	x	x	x	x	x	x	x	x	x	x	0
0	1	1	0	0	x	x	x	x	x	x	0	x	x	x	x	x	x	x	x	x	1
0	1	1	0	0	x	x	x	x	x	x	1	x	x	x	x	x	x	x	x	x	0
0	1	1	1	0	x	x	x	x	x	x	x	0	x	x	x	x	x	x	x	x	1
0	1	1	1	0	x	x	x	x	x	x	x	1	x	x	x	x	x	x	x	x	0
1	0	0	0	0	x	x	x	x	x	x	x	x	0	x	x	x	x	x	x	x	1
1	0	0	0	0	x	x	x	x	x	x	x	x	1	x	x	x	x	x	x	x	0
1	0	0	1	0	x	x	x	x	x	x	x	x	x	0	x	x	x	x	x	x	1
1	0	0	1	0	x	x	x	x	x	x	x	x	x	1	x	x	x	x	x	x	0
1	0	1	0	0	x	x	x	x	x	x	x	x	x	x	1	x	x	x	x	x	0
1	0	1	0	0	x	x	x	x	x	x	x	x	x	x	x	0	x	x	x	x	1
1	0	1	1	0	x	x	x	x	x	x	x	x	x	x	x	1	x	x	x	x	0
1	1	0	0	0	x	x	x	x	x	x	x	x	x	x	x	x	0	x	x	x	1
1	1	0	0	0	x	x	x	x	x	x	x	x	x	x	x	x	1	x	x	x	0
1	1	0	1	0	x	x	x	x	x	x	x	x	x	x	x	x	0	x	x	x	1
1	1	0	1	0	x	x	x	x	x	x	x	x	x	x	x	x	1	x	x	x	0
1	1	1	0	0	x	x	x	x	x	x	x	x	x	x	x	x	x	0	x	x	1
1	1	1	0	0	x	x	x	x	x	x	x	x	x	x	x	x	x	1	x	x	0
1	1	1	1	0	x	x	x	x	x	x	x	x	x	x	x	x	x	x	x	0	1
1	1	1	1	0	x	x	x	x	x	x	x	x	x	x	x	x	x	x	x	1	0

When used to indicate an input condition, x = logical 1 or logical 0.

A.10 74153 DUAL 4-LINE-TO-1-LINE DATA SELECTORS/MULTIPLEXERS

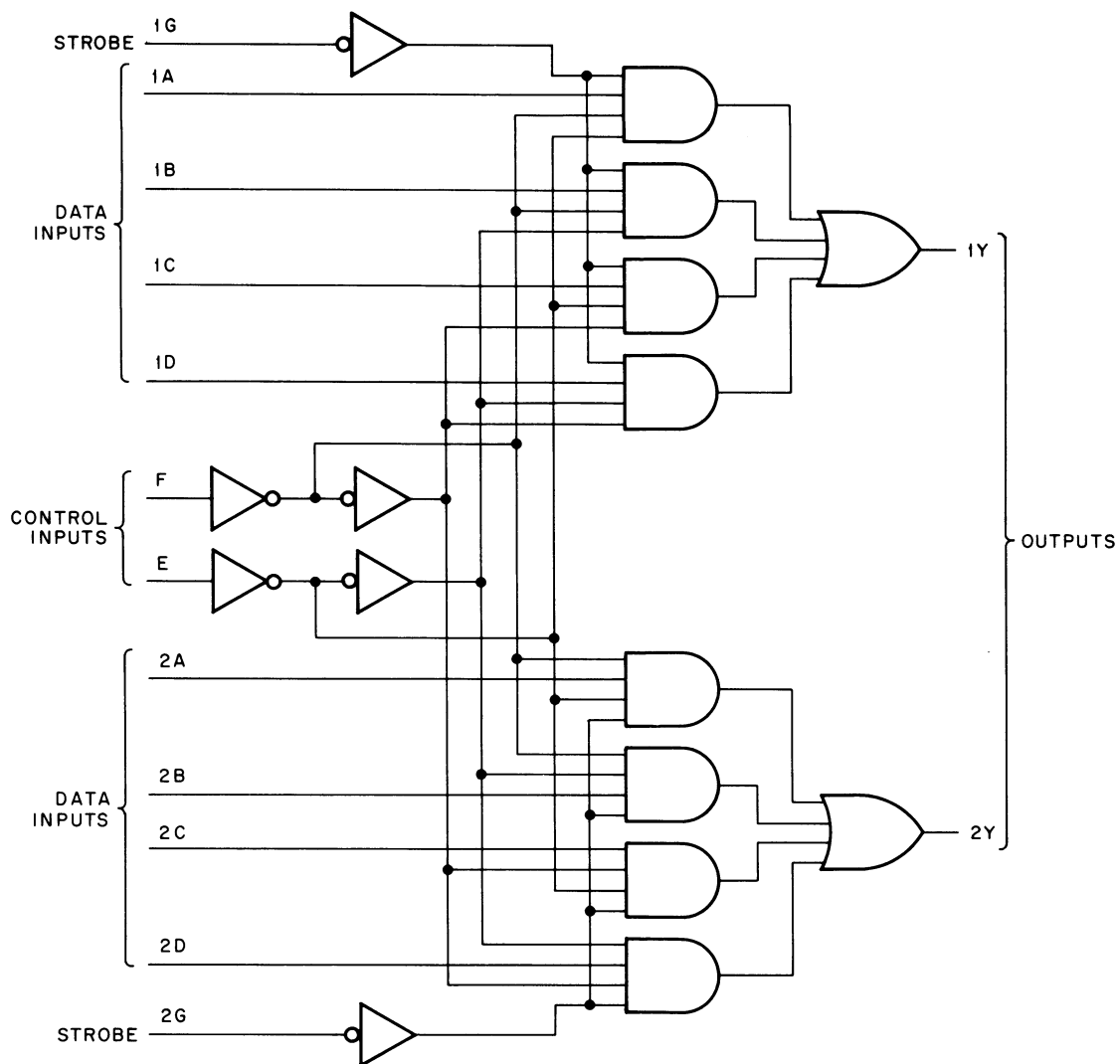

LOGIC DIAGRAM

CONTROL INPUT		STROBE	OUTPUT
E	F	G	Y
LOW	LOW	LOW	A
HIGH	LOW	LOW	B
LOW	HIGH	LOW	C
HIGH	HIGH	LOW	D
DON'T CARE		HIGH	LOW

TRUTH TABLE (EACH HALF)

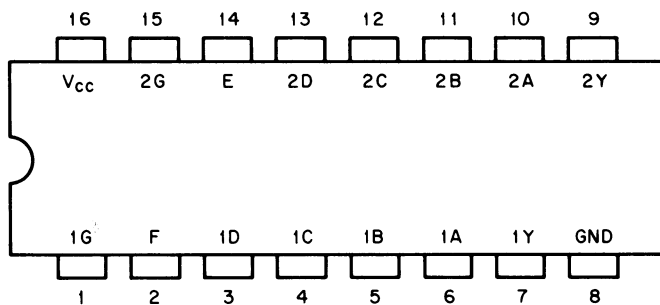

PIN LOCATOR
(TOP VIEW OF IC)

8E-0138

A.11 74154 4-LINE-TO-16-LINE DECODERS/DEMULTIPLEXERS

DUAL-IN-LINE PACKAGE (TOP VIEW)

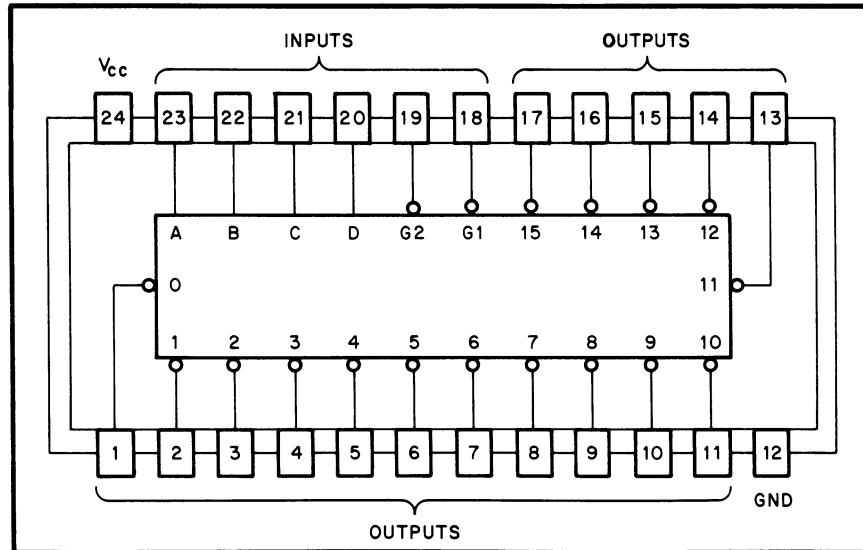

II-0636

TRUTH TABLE

Inputs					Outputs																	
G1	G2	D	C	B	A	0	1	2	3	4	5	6	7	8	9	10	11	12	13	14	15	
L	L	L	L	L	L	L	H	H	H	H	H	H	H	H	H	H	H	H	H	H	H	H
L	L	L	L	L	H	H	L	H	H	H	H	H	H	H	H	H	H	H	H	H	H	H
L	L	L	L	H	L	H	H	L	H	H	H	H	H	H	H	H	H	H	H	H	H	H
L	L	L	L	H	H	H	H	L	H	H	H	H	H	H	H	H	H	H	H	H	H	H
L	L	L	H	L	L	H	H	H	H	L	H	H	H	H	H	H	H	H	H	H	H	H
L	L	L	H	H	L	H	H	H	H	H	L	H	H	H	H	H	H	H	H	H	H	H
L	L	L	H	H	H	H	H	H	H	H	H	L	H	H	H	H	H	H	H	H	H	H
L	L	H	L	L	L	H	H	H	H	H	H	H	L	H	H	H	H	H	H	H	H	H
L	L	H	L	H	L	H	H	H	H	H	H	H	H	H	L	H	H	H	H	H	H	H
L	L	H	H	L	L	H	H	H	H	H	H	H	H	H	H	H	L	H	H	H	H	H
L	L	H	H	L	H	H	H	H	H	H	H	H	H	H	H	H	H	L	H	H	H	H
L	L	H	H	H	L	H	H	H	H	H	H	H	H	H	H	H	H	H	L	H	H	H
L	L	H	H	H	H	H	H	H	H	H	H	H	H	H	H	H	H	H	H	L	H	H
L	H	X	X	X	X	H	H	H	H	H	H	H	H	H	H	H	H	H	H	H	H	H
H	L	X	X	X	X	H	H	H	H	H	H	H	H	H	H	H	H	H	H	H	H	H
H	H	X	X	X	X	H	H	H	H	H	H	H	H	H	H	H	H	H	H	H	H	H

H = high, L = low, X = irrelevant

A.12 74157/74S158 QUADRUPLE 2-LINE-TO-1-LINE MULTIPLEXER

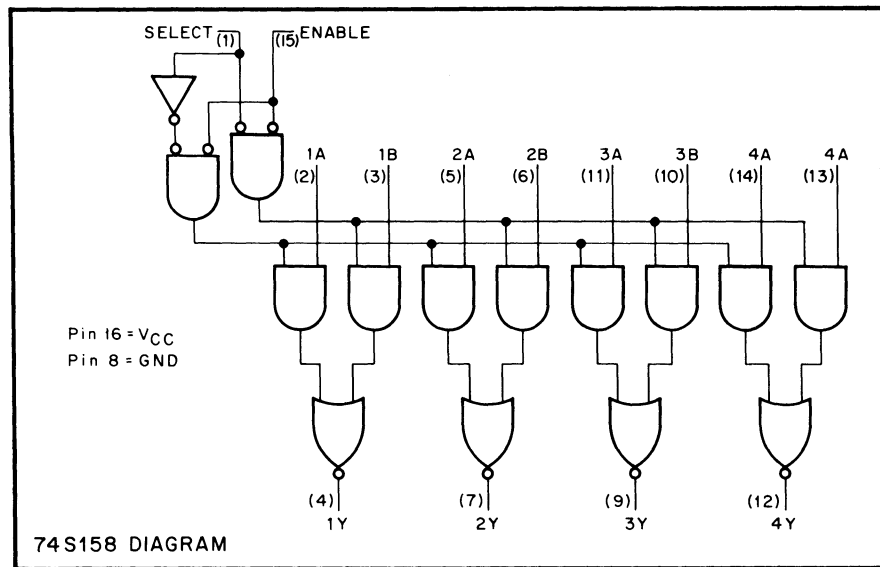

TRUTH TABLE

INPUTS			OUTPUT Y	OUTPUT W
ENABLE	SELECT	A B	74157	74S158
H	X	X X	L	H
L	L	L X	L	H
L	L	H X	H	L
L	H	X L	L	H
L	H	X H	H	L

H=High level, L=Low level, X=Irrelevant

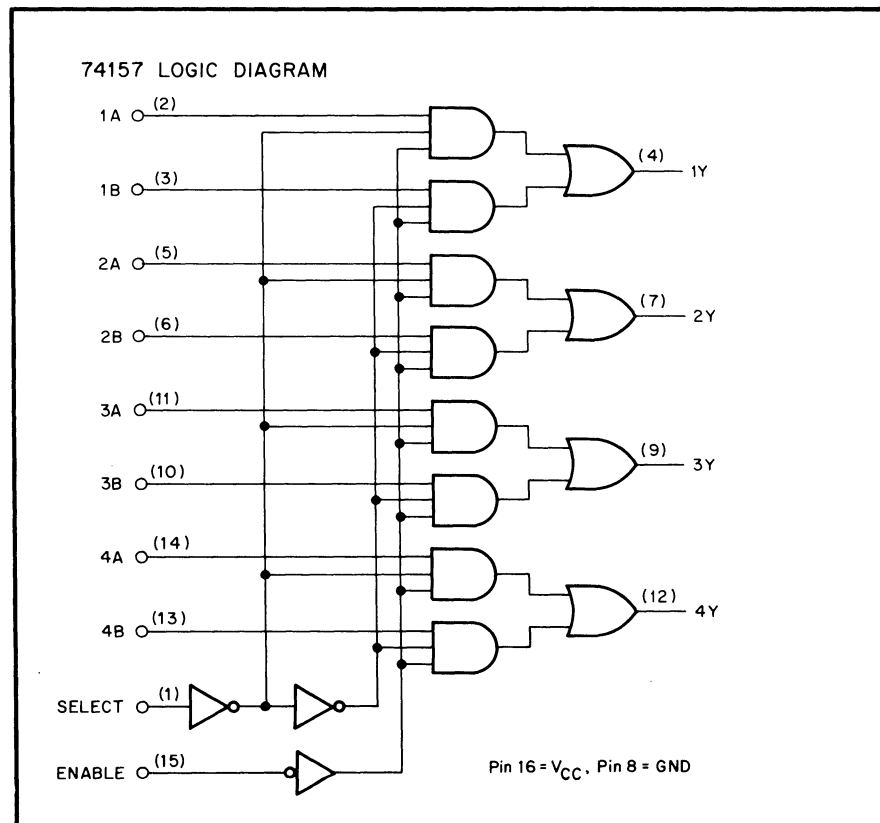

11-1131

A.13 74174 HEX/74175 QUAD D-TYPE FLIP-FLOPS WITH CLEAR

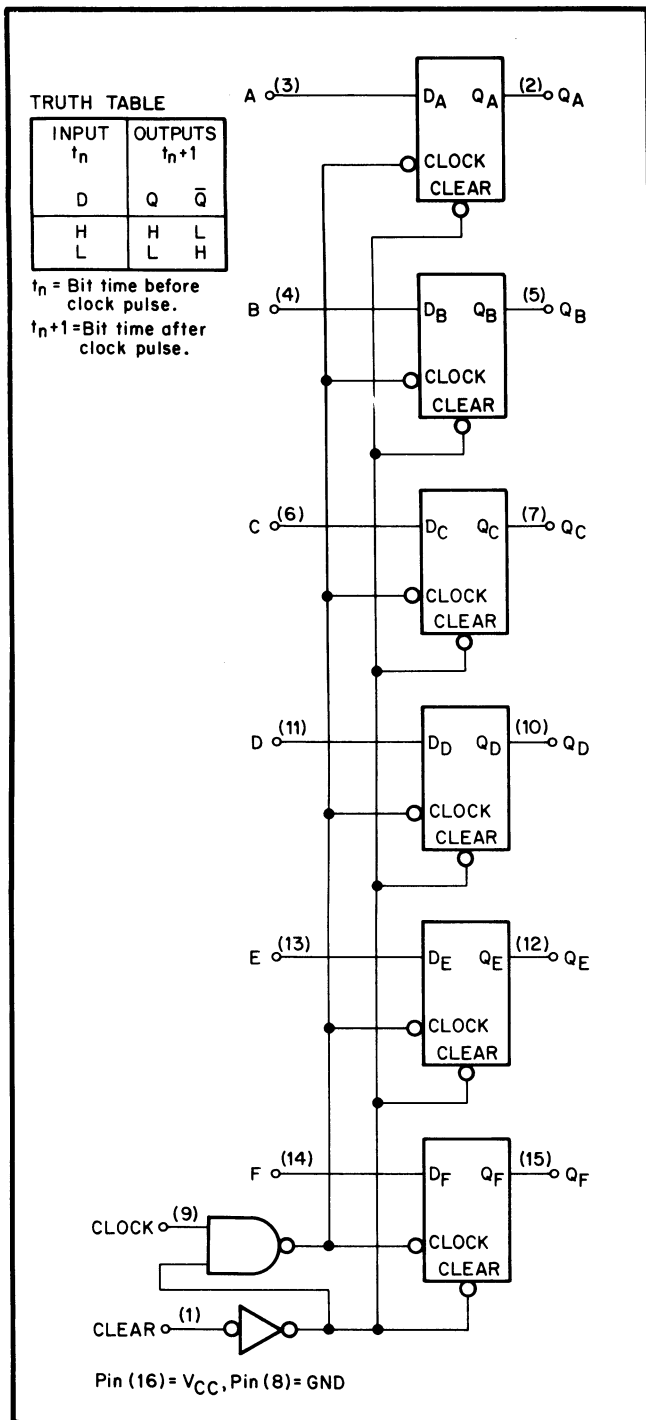

11-1112

74174 Diagram

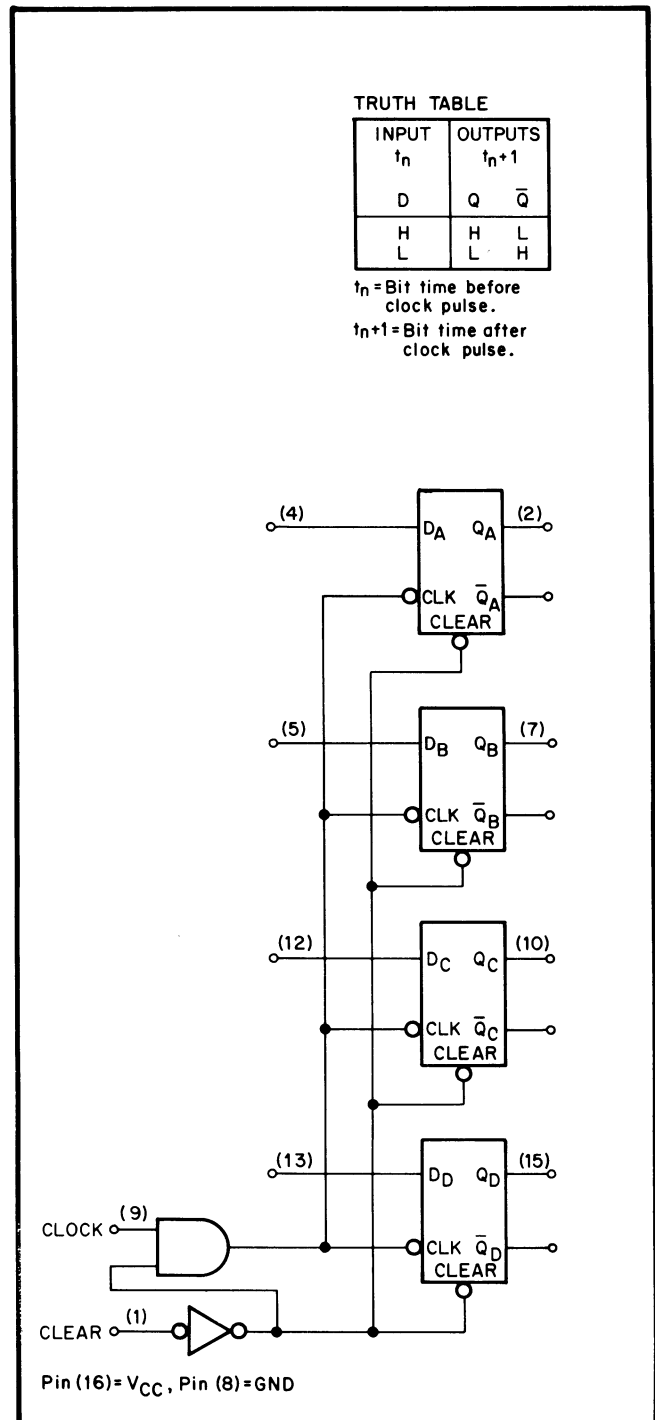

11-1113

74175 Diagram

A.14 74181 ARITHMETIC LOGIC UNIT/FUNCTION GENERATOR (ALU)

Selection S ₃ S ₂ S ₁ S ₀				Active-Low Data		
				M = H Logic Functions	M = L; Arithmetic Operations	
					C _n = 0 C _n = 0 = L	C _n = 1 C _n = 1 = H
L	L	L	L	$F = \overline{A}$	F = A MINUS 1	F = A
L	L	L	H	$F = \overline{AB}$	F = AB MINUS 1	F = AB
L	L	H	L	$F = \overline{A} + B$	F = \overline{AB} MINUS 1	F = \overline{AB}
L	L	H	H	F = 1	F = MINUS 1 (2's COMP)	F = ZERO
L	H	L	L	$F = \overline{A + B}$	F = A PLUS (A + \overline{B})	F = A PLUS (A + \overline{B}) PLUS 1
L	H	L	H	$F = \overline{B}$	F = AB PLUS (A + \overline{B})	F = AB PLUS (A + \overline{B}) PLUS 1
L	H	H	L	$F = A \oplus \overline{B}$	F = A MINUS B MINUS 1	F = A MINUS B
L	H	H	H	$F = \overline{A + B}$	F = A + \overline{B}	F = (A + \overline{B}) PLUS 1
H	L	L	L	$F = \overline{AB}$	F = A PLUS (A + B)	F = A PLUS (A + B) PLUS 1
H	L	L	H	$F = A \oplus B$	F = A PLUS B	F = A PLUS B PLUS 1
H	L	H	L	F = B	F = \overline{AB} PLUS (A + B)	F = \overline{AB} PLUS (A + B) PLUS 1
H	L	H	H	F = A + B	F = A + B	F = (A + B) PLUS 1
H	H	L	L	F = 0	F = A PLUS A	F = A PLUS A PLUS 1
H	H	L	H	$F = \overline{AB}$	F = AB PLUS A	F = AB PLUS A PLUS 1
H	H	H	L	F = AB	F = \overline{AB} PLUS A	F = \overline{AB} PLUS A PLUS 1
H	H	H	H	F = A	F = A	F = A PLUS 1

PIN DESIGNATIONS

Designation	Pin No.	Function
$\bar{A}3, \bar{A}2, \bar{A}1, \bar{A}0$	19, 21, 23, 2	WORD A INPUTS
$\bar{B}3, \bar{B}2, \bar{B}1, \bar{B}0$	18, 20, 22, 1	WORD B INPUTS
S3, S2, S1, S0	3, 4, 5, 6	FUNCTION-SELECT INPUTS
C_n	7	CARRY INPUT
M	8	MODE CONTROL INPUT
$\bar{F}3, \bar{F}2, \bar{F}1, \bar{F}0$	13, 11, 10, 9	FUNCTION OUTPUTS
A = B	14	COMPARATOR OUTPUT
P	15	CARRY PROPAGATE OUTPUT
C_{n+4}	16	CARRY OUTPUT
\bar{G}	17	CARRY GENERATE OUTPUT
V_{CC}	24	SUPPLY VOLTAGE
GND	12	GROUND

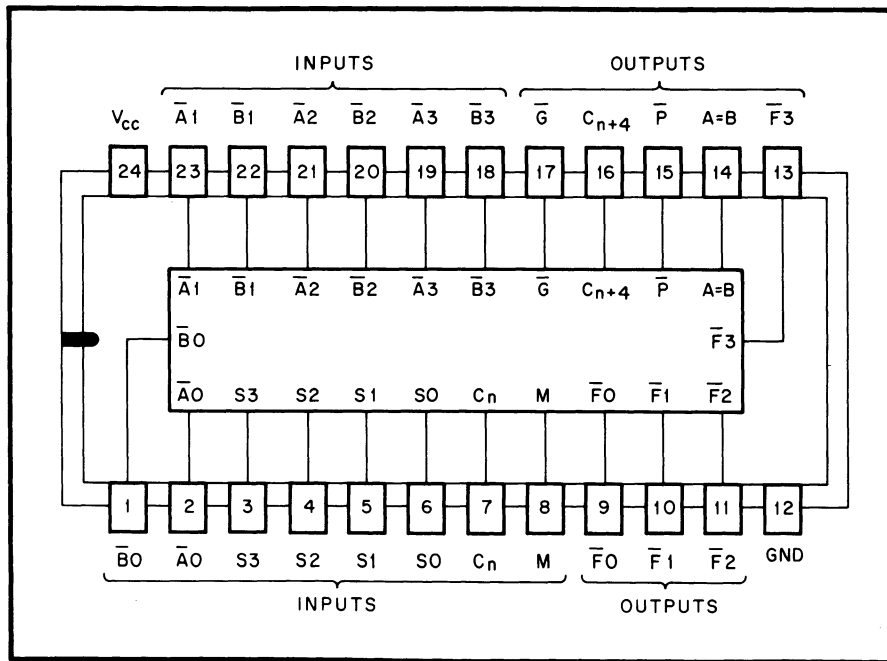

12-0321

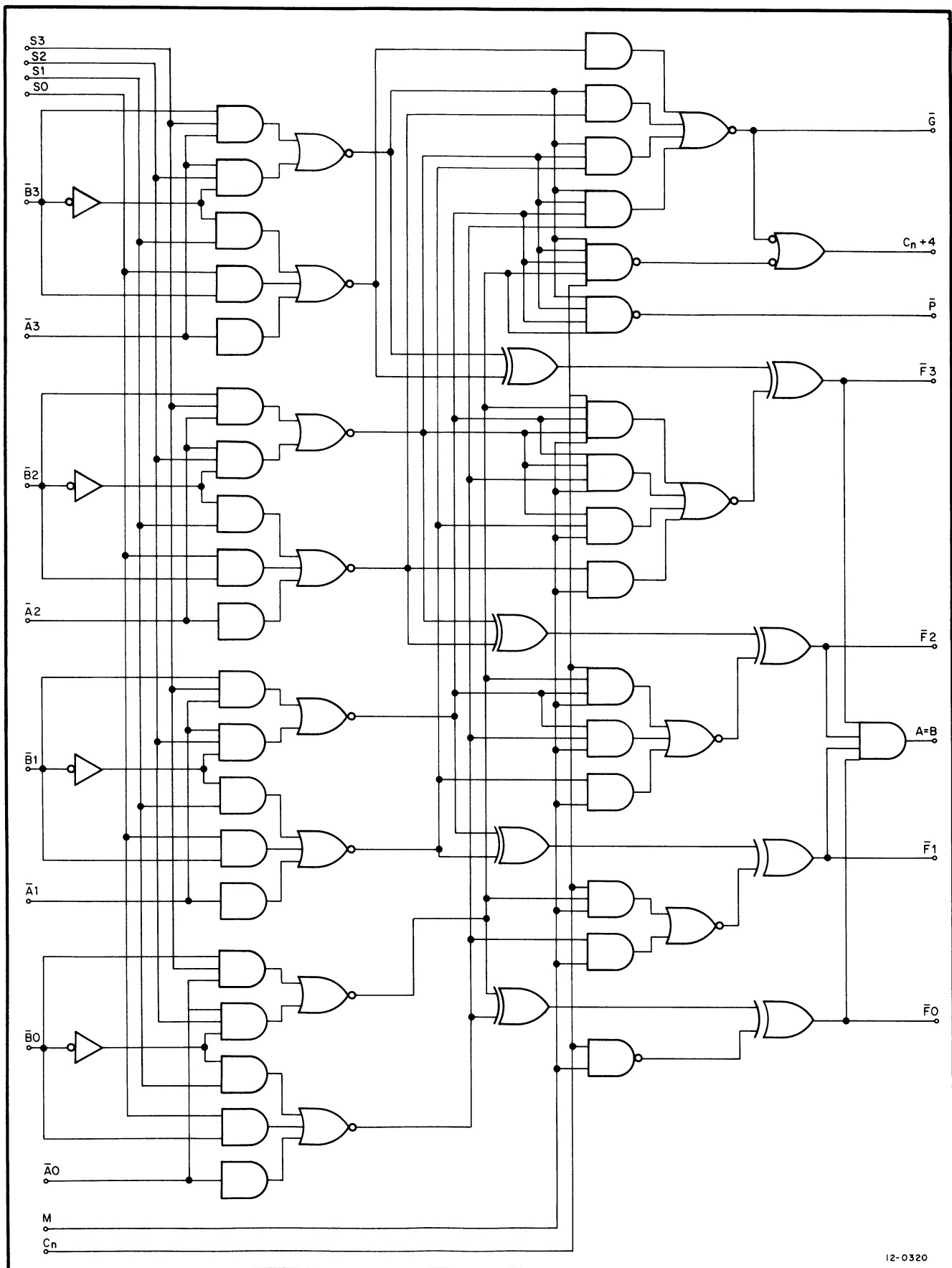

A.15 74182 LOOK-AHEAD CARRY GENERATOR

Equations:

$$C_{n+x} = G_0 + P_0 C_n$$

$$C_{n+y} = G_1 + P_1 G_0 + P_1 P_0 C_n$$

$$C_{n+z} = G_2 + P_2 G_1 + P_2 P_1 G_0 + P_2 P_1 P_0 C_n$$

$$\bar{G} = G_3 + P_3 G_1 + P_3 P_2 G_1 + P_3 P_2 P_1 G_0$$

$$\bar{P} = P_3 P_2 P_1 P_0$$

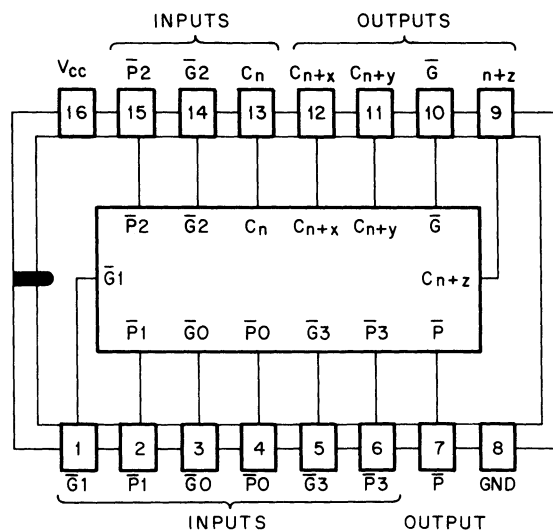

12-0326

PIN DESIGNATIONS

Designation	Pin No.	Function
$\bar{G}_0, \bar{G}_1, \bar{G}_2, \bar{G}_3$	3, 1, 14, 5	ACTIVE-LOW CARRY GENERATE INPUTS
$\bar{P}_0, \bar{P}_1, \bar{P}_2, \bar{P}_3$	4, 2, 15, 6	ACTIVE-LOW CARRY PROPAGATE INPUTS
C_n	13	CARRY INPUT
$C_{n+x}, C_{n+y}, C_{n+z}$	12, 11, 9	CARRY OUTPUTS
\bar{G}	10	ACTIVE-LOW CARRY GENERATE OUTPUT
\bar{P}	7	ACTIVE-LOW CARRY PROPAGATE OUTPUT
V_{CC}	16	SUPPLY VOLTAGE
GND	8	GROUND

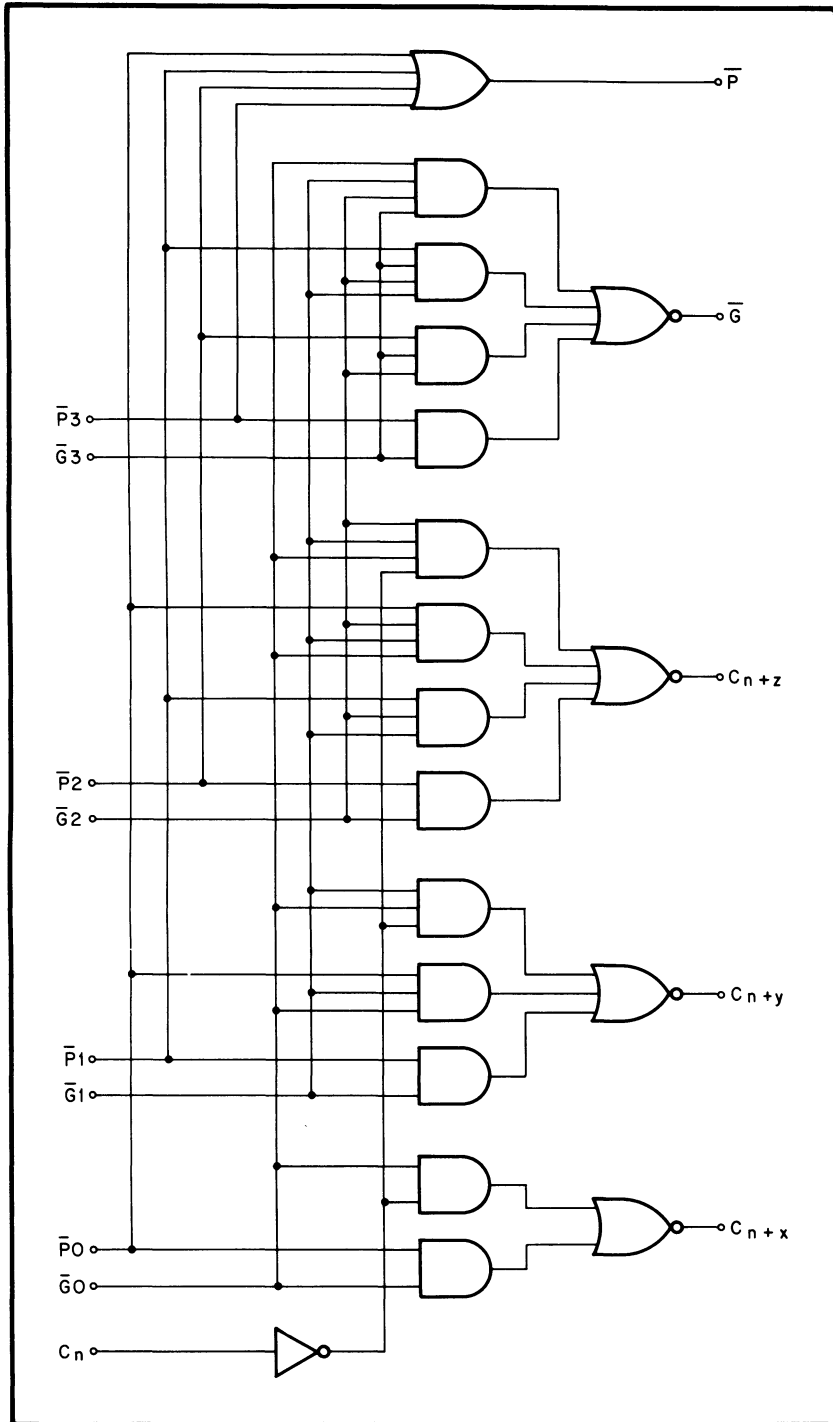

12-0323

A.16 74193 SYNCHRONOUS 4-BIT UP/DOWN COUNTER (DUAL CLOCK WITH CLEAR)

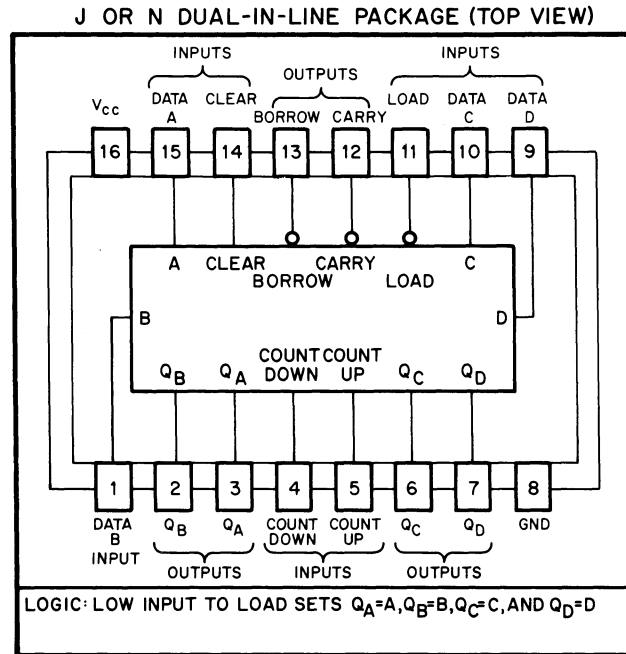

11-0640

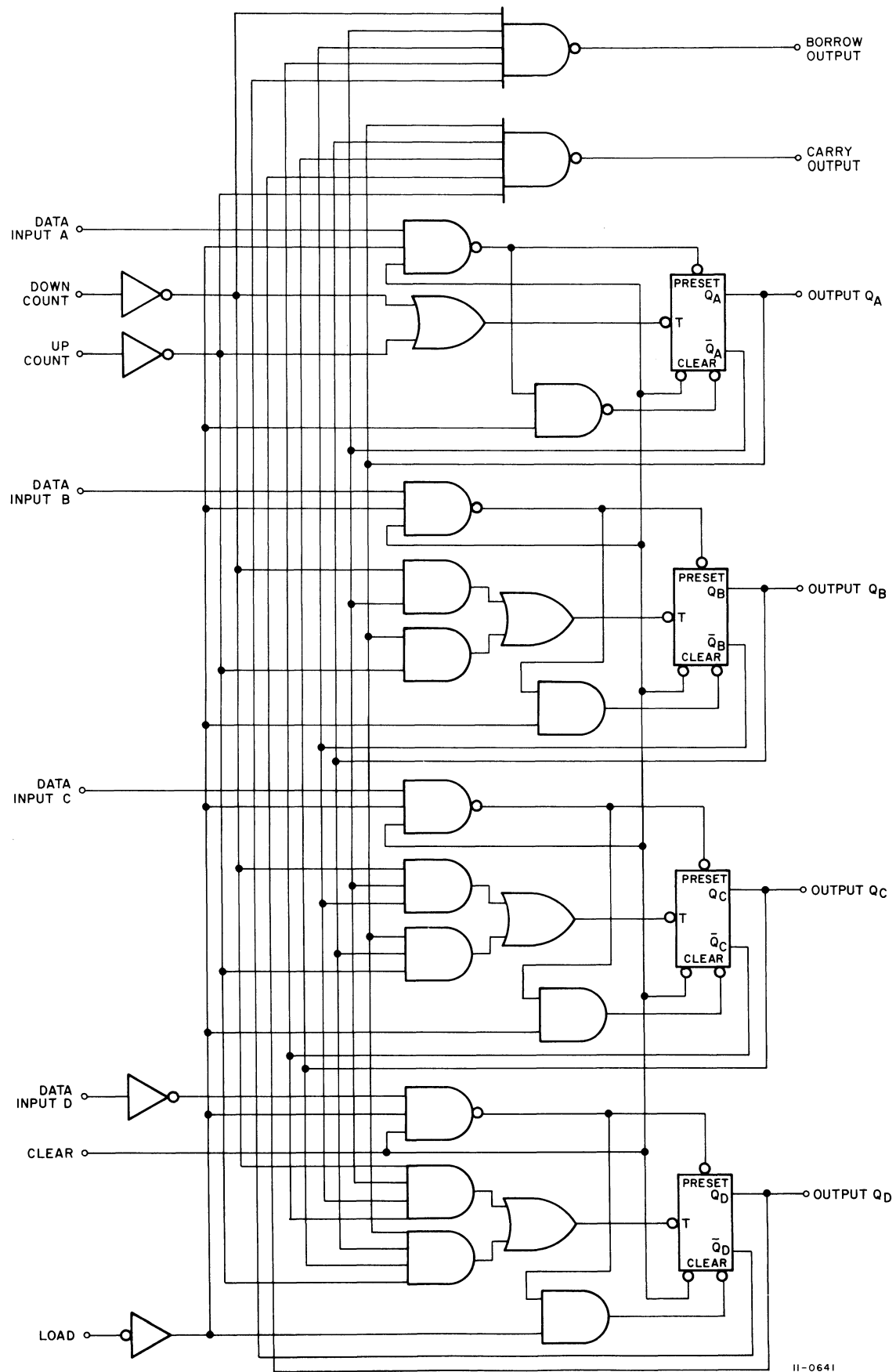

11-0641

A.17 74194 4-BIT BIDIRECTIONAL UNIVERSAL SHIFT REGISTERS

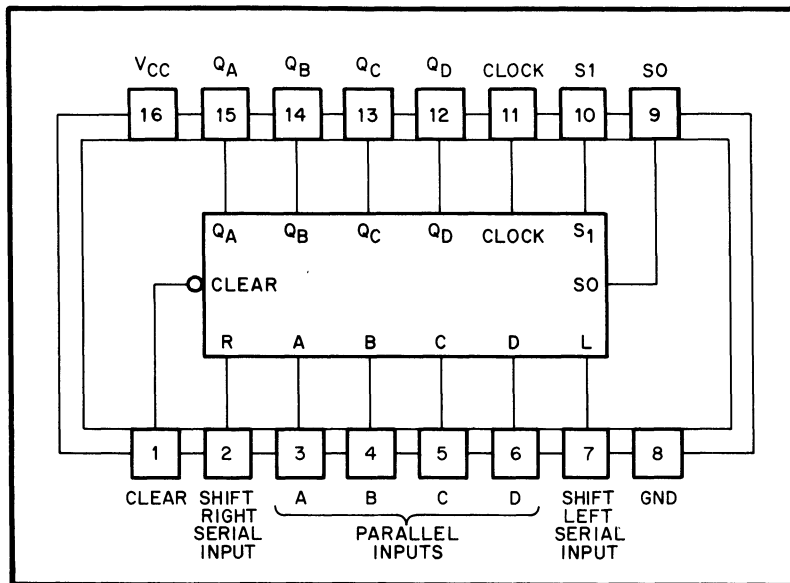

11-1121

A.18 7528 DUAL SENSE AMPLIFIERS WITH PREAMPLIFIER TEST POINTS

TRUTH TABLE

INPUTS		OUTPUT
A	S	W
H	H	H
L	X	L
X	L	L

DEFINITION OF LOGIC LEVEL

INPUT	H	L	X
A†	$V_{ID} > V_T \text{ MAX}$	$V_{ID} < V_T \text{ MIN}$	IRRELEVANT
S	$V_I > V_{IH} \text{ MIN}$	$V_I < V_{IL} \text{ MAX}$	IRRELEVANT

†A is a differential voltage (V_{ID}) between A1 and A2. For these circuits V_{ID} is considered positive regardless of which terminal is positive with respect to the other.

11-1122

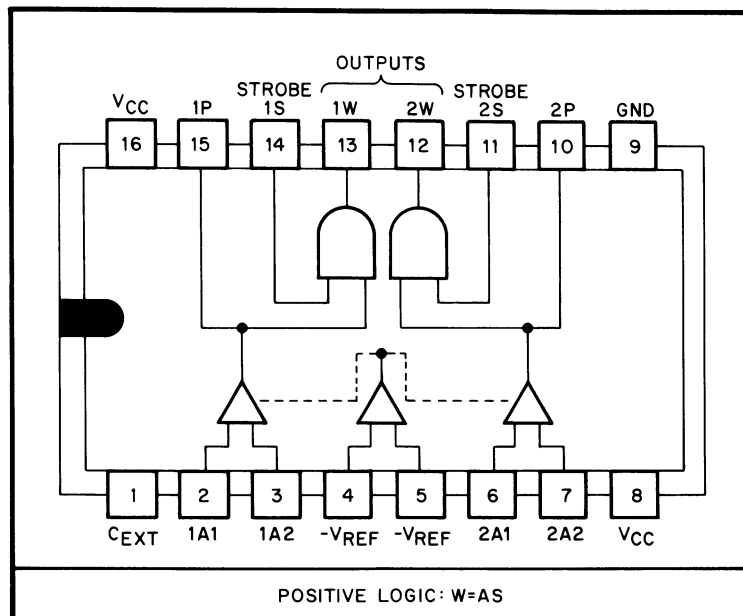

A.19 9602 DUAL RETRIGGERABLE MONOSTABLE MULTIVIBRATOR WITH CLEAR

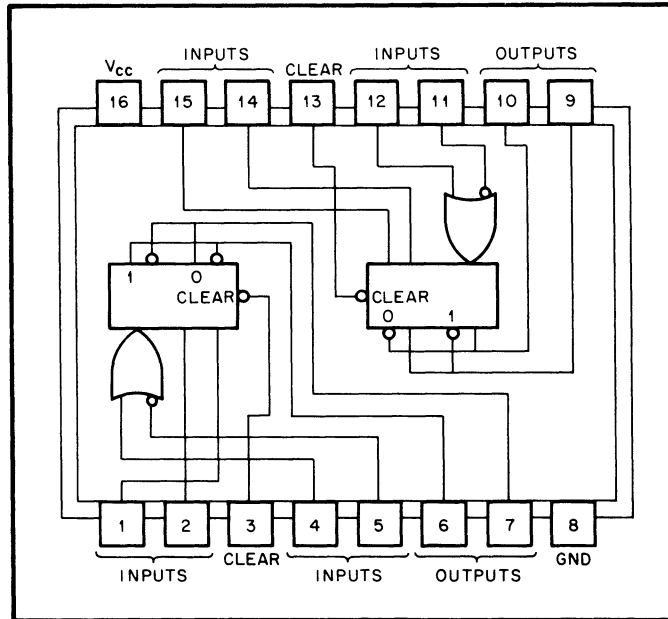

TRUTH TABLE

A	B	1	0
H	↑		
↓	L		

H = HIGH LEVEL
 L = LOW LEVEL
 ↑ = LOW TO HIGH TRANSITION
 ↓ = HIGH TO LOW TRANSITION

11-1130

APPENDIX B COMPUTER CONNECTORS

Table B-1 lists the computer connectors, the connector type, part number, pin and signal designations, and the associated connector cable. This includes the connectors for the SCL cable that interfaces the computer (Berg) connector to an LA30 or Model 33 ASR Teletype equivalent (Mate-N-Lok) connector. The power supply connectors are described in Part 4 of this manual.

**Table B-1
Connectors**

Connector	Type	Part Number	Designations		Cable
			Pin	Signals	
SCL Connector	40-pin Berg	549949 (Female) 1270090-0 (Male)	BB	-15V	70-8820
			V	SER 0+ (20 mA)	
			T	CLK IN (TTL)	
			DD	SER IN - (20 mA)	
			R	READER RUN - (20 mA)	
			N	CLK DISAB (TTL)	
			L	SER 0 - (20 mA)	
			C	+5V	
			D	SER 0 (TTL)	
			F	READER RUN + (20 mA)	
			RR	SER IN (TTL)	
			NN	20 mA INTERLOCK	
			LL	SERIAL IN + (20 mA)	
Teletype or LA30 Connector	6-pin Mate-N-Lok (Female)	1209340	2	SER 0 -	70-8360
			3	-15V	
			4	-15V	
			5	SER 0 +	
			6	READER RUN	
			7	SER IN	
Console	40-pin Berg Connector	549949 (Female) 1270090-0	PP	DAK H	BC08R-03
			BB	SW 15 (1) H	
			DD	SW 14 (1) H	
			FF	SW 13 (1) H	
			JJ	SW 12 (1) H	
			LL	SW 11 (1) H	

Table B-1 (Cont)
Connectors

Connector	Type	Part Number	Designations		Cable
			Pin	Signals	
Console (cont)			NN	SW 10 (1) H	
			RR	SW 09 (1) H	
			TT	SW 08 (1) H	
			J	SW 07 (1) H	
			L	SW 06 (1) H	
			N	SW 05 (1) H	
			R	SW 04 (1) H	
			T	SW 03 (1) H	
			V	SW 02 (1) H	
			X	SW 01 (1) H	
			Z	SW 00 (1) H	
			HH	SCAN ADRS 01 (1) L	
			KK	SCAN ADRS 02 (1) L	
			MM	SCAN ADRS 03 (1) L	
			SS	SCAN ADRS 04 (1) L	
			CC	PUP L	
			C	RUN L	
			E	KEY LOAD ADRS (1) L	
			H	KEY EXAM (1) L	
			K	KEY CONT (1) L	
M	KEY HLT ENB (1) L				
P	KEY START (1) L				
S	KEY DEP (1) L				
Unibus	M920 or M930		AA1	INIT L	
			AA2	POWER (+5V)	
			AB1	INTR L	
			AB2	GROUND	
			AC1	D00 L	
			AC2	GROUND	
			AD1	D02 L	
			AD2	D01 L	
			AE1	D04 L	
			AE2	D03 L	
			AF1	D06 L	
			AF2	D05 L	
			AH1	D08 L	
			AH2	D07 L	
			AJ1	D10 L	
			AJ2	D09 L	
			AK1	D12 L	
			AK2	D11 L	
AL1	D14 L				
AL2	D13 L				
AM1	PA L				
AM2	D15 L				
AN1	GROUND				

Table B-1 (Cont)
Connectors

Connector	Type	Part Number	Designation		Cable
			Pin	Signals	
Unibus (cont)			AN2	PBL	
			AP1	GROUND	
			AP2	BBSY L	
			AR1	GROUND	
			AR2	SACK L	
			AS1	GROUND	
			AS2	NPR L	
			AT1	GROUND	
			AT2	BR 7 L	
			AU1	NPG H	
			AU2	BR 6 L	
			AV1	BG 7 H	
			AV2	GROUND	
			BA1	BG 6 H	
			BA2	POWER (+5V)	
			BB1	BG 5 H	
			BB2	GROUND	
			BC1	BR 5 L	
			BC2	GROUND	
			BD1	GROUND	
			BD2	BR 4 L	
			BE1	GROUND	
			BE2	BG 4 H	
			BF1	AC LO L	
			BF2	DC LO L	
			BH1	A01L	
			BH2	A00L	
			BJ1	A03L	
			BJ2	A02L	
			BK1	A05L	
			BK2	A04L	
			BL1	A07L	
			BL2	A06L	
			BM1	A09L	
BM2	A08L				
BN1	A11L				
BN2	A10L				
BP1	A13L				
BP2	A12L				
BR1	A15L				
BR2	A14L				
BS1	A17L				
BS2	A16L				
BT1	GROUND				
BT2	C1 L				
BU1	SSYN L				

**Table B-1 (Cont)
Connectors**

Connector	Type	Part Number	Designation		Cable
			Pin	Signals	
Unibus (cont)			BU2 BV1 BV2	CO L MSYN L GROUND	
AC Remote Power Turn-On Connector	Two 3-pin Mate-N-Loks (J6 and J7)	DEC 2-09350-03 (Plug is DEC 12-09351)	1 2 3	Power Request Emergency shutdown Ground	Power Supply AC Cable
Line Cord Connector	AC Line Plug				(110V) BC05H (230V) BC05J

READER'S COMMENTS

**PDP-11/05, 11/10 COMPUTER MANUAL
DEC-11-H05AA-B-D**

Your comments and suggestions will help us in our continuous effort to improve the quality and usefulness of our publications.

What is your general reaction to this manual? In your judgment is it complete, accurate, well organized, well written, etc.? Is it easy to use? _____

What features are most useful? _____

What faults do you find with the manual? _____

Does this manual satisfy the need you think it was intended to satisfy? _____

Does it satisfy *your* needs? _____ Why? _____

Would you please indicate any factual errors you have found. _____

Please describe your position. _____

Name _____ Organization _____

Street _____ Department _____

City _____ State _____ Zip or Country _____

Fold Here

Do Not Tear - Fold Here and Staple

FIRST CLASS
PERMIT NO. 33
MAYNARD, MASS.

BUSINESS REPLY MAIL
NO POSTAGE STAMP NECESSARY IF MAILED IN THE UNITED STATES

Postage will be paid by:

Digital Equipment Corporation
Technical Documentation Department
146 Main Street
Maynard, Massachusetts 01754

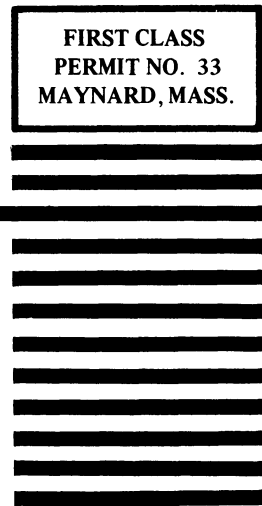

**PDP-11/05, 11/10
10½ inch mounting box
and power system**

1st Edition, July 1973
2nd Printing, September 1973
3rd Printing, July 1974

Copyright © 1973, 1974 by Digital Equipment Corporation

The material in this manual is for informational purposes and is subject to change without notice.

Digital Equipment Corporation assumes no responsibility for any errors which may appear in this manual.

Printed in U.S.A.

The following are trademarks of Digital Equipment Corporation, Maynard, Massachusetts:

DEC	PDP
FLIP CHIP	FOCAL
DIGITAL	COMPUTER LAB
UNIBUS	

CONTENTS

	Page	
CHAPTER 1	MOUNTING BOX	
1.1	INTRODUCTION	1-1
1.2	OVERALL MECHANICAL DESCRIPTION	1-1
1.3	BACKPLANE	1-5
1.4	POWER SYSTEM	1-9
CHAPTER 2	UNPACKING AND INSTALLATION	
2.1	INTRODUCTION	2-1
2.2	UNPACKING	2-1
2.3	INSTALLATION IN A CABINET	2-1
2.4	INSTALLATION OF OPTIONS AND CABLES	2-2
2.4.1	Installing Options on Site	2-2
2.4.2	Connecting the Serial Communications Device to the Processor	2-4
2.5	AC POWER SUPPLY CONNECTION	2-4
2.5.1	Connecting to Voltages Other than 115 V	2-4
2.5.2	Quality of AC Power Source	2-5
2.6	CABINET POWER CONTROL	2-5
2.6.1	Introduction	2-5
2.6.2	Typical Multi-Cabinet Installation	2-6
2.7	INSTALLATION CERTIFICATION	2-7
2.8	WARRANTY SERVICE (DOMESTIC ONLY)	2-8
CHAPTER 3	POWER SYSTEM	
3.1	INTRODUCTION	3-1
3.2	MECHANICAL DESCRIPTION	3-1
3.2.1	Power Supply	3-1
3.2.1.1	DC Regulator	3-5
3.2.1.2	+5 V Regulator	3-7
3.2.2	Line Set	3-7
3.2.3	Wiring Harnesses	3-11
3.3	SYSTEM FUNCTIONAL DESCRIPTION	3-11
3.4	SYSTEM CIRCUIT DESCRIPTION	3-11
3.4.1	Introduction	3-11
3.4.2	Line Set	3-11
3.4.3	Power Distribution Board	3-11
3.4.4	DC Regulator (PS1)	3-19
3.4.4.1	Functional Operation	3-19
3.4.4.2	Generation of Raw DC Voltages	3-19
3.4.4.3	LTC L Circuit	3-20
3.4.4.4	BUS AC LO L and BUS DC LO L Circuits	3-20
3.4.4.5	+15 V Regulator Circuit	3-21
3.4.4.6	+5 V Regulator Circuit	3-22
3.4.4.7	-15 V Regulator Circuit	3-23
3.4.5	+5 V Regulator (PS2)	3-23
3.4.5.1	Functional Operation	3-23
3.4.5.2	Generation of Raw DC Voltage	3-26
3.4.5.3	Regulator Circuit	3-26

CONTENTS (Cont)

		Page
3.4.5.4	Overcurrent Protection Circuit	3-28
3.4.5.5	Overvoltage Crowbar Circuit	3-28
3.5	POWER SUPPLY MAINTENANCE	3-28
3.5.1	Introduction	3-28
3.5.2	Checking and Adjusting Voltages	3-28
3.5.3	Power Supply Removal	3-30
3.5.4	Troubleshooting Procedures	3-37
3.5.4.1	Introduction	3-37
3.5.4.2	Troubleshooting Hints	3-37
3.5.4.3	Troubleshooting the 5409728 Regulator	3-37
3.5.4.4	Troubleshooting the H744 Regulator	3-39

APPENDIX A DC REGULATOR 5409728 SPECIFICATIONS A-1

APPENDIX B CABLE CONNECTORS

B.1	INTRODUCTION	B-1
B.2	SERIAL COMMUNICATIONS LINE INTERFACE	B-1
B.3	CONSOLE CABLE	B-1
B.4	UNIBUS CABLE/JUMPER	B-1

ILLUSTRATIONS

Figure No.	Title	Page
1-1	PDP-11/05 NC Computer Mounted In Cabinet	1-2
1-2	PDP-11/05 NC Computer Extended and Locked In Front Down 90° Position	1-3
1-3	PDP-11/05 NC Computer Extended and Locked In Front Up 90° Position	1-4
1-4	PDP-11/05 NC Computer, Rear View	1-5
1-5	Connector Side of Backplane	1-6
1-6	Pin Side of Backplane	1-6
1-7	Computer Backplane Connector and Pin Designations	1-7
1-8	Module Contact Designations	1-8
1-9	Module Utilization Diagram	1-9
2-1	Computer Packaging	2-2
2-2	Connector Specifications for Line Set	2-4
2-3	Typical Cabinet Power Control System Wiring Diagram	2-5
2-4	Interconnection of Power Controllers in Multi Cabinet Installation	2-6
3-1	Power Supply Side View	3-2
3-2	Power Supply, Front and Rear Views	3-3
3-3	DC Regulator, Top View	3-5
3-4	DC Regulator, Bottom View	3-6
3-5	+5 V Regulator, Side View	3-8
3-6	+5 V Regulator, 3/4 Bottom View	3-9
3-7	BC05T Line Set, Cover Removed	3-10
3-8	BC05T Line Set, Rear View	3-10
3-9	Power System Functional Block Diagram	3-12
3-10	Power System Interconnection Diagram	3-13
3-11	Power Application Using 115 V Line Set	3-15

ILLUSTRATIONS (Cont)

		Page
3-12	Power Application Using 230 V Line Set	3-15
3-13	Power Distribution Board Circuit Schematic	3-16
3-14	DC Regulator Block Diagram	3-18
3-15	Rectifier and LTC Circuits	3-20
3-16	BUS AC LO and BUS DC LO Circuits	3-21
3-17	+15 V Regulator Circuit	3-22
3-18	+5 V Regulator Circuit	3-22
3-19	-15 V Regulator Circuit	3-24
3-20	+5 V Regulator (PS2) Functional Block Diagram	3-24
3-21	+5 V Regulator (PS2) Circuit Schematic	3-25
3-22	Voltage Regulator (E1) Equivalent Circuit and Package Configuration	3-26
3-23	Simplified 5 V Switching Regulator Schematic and Waveforms	3-27
3-24	Power Supply Adjustments	3-29
3-25	Disconnecting Line Set From Power Supply	3-31
3-26	Removing Power Supply Mounting Screws	3-33
3-27	Removing Power Distribution Harness Connectors H2–P2 and H2–P3	3-33
3-28	Lifting Power Supply From Mounting Box	3-35
3-29	Disconnecting DC Regulator Output Connector	3-35
3-30	+5 V Regulator Circuit Waveforms	3-40
3-31	-15 V Regulator Circuit Waveforms	3-41
B-1	SCL Cable 70-08360	B-2

TABLES

Table No.	Title	Page
3-1	Power Distribution Board Signals	3-16
3-2	Option Power Harnesses	3-17
3-3	5409728 Regulator Troubleshooting Chart	3-38
A-1	Input Specifications	A-1
A-2	Output Specifications	A-2
A-3	Mechanical and Environmental Specifications	A-5
B-1	SCL Interface Pin and Signal Designations	B-3
B-2	BC08R-03 Console Cable Pin and Signal Designations	B-5
B-3	Unibus BC11A Cable/M920 Jumper Pin and Signal Designations	B-6

INTRODUCTION

This publication is a supplement to the *PDP-11/05, 11/10 Computer Manual*, DEC-11-H05AA-B-D. It discusses the following PDP-11/05 and PDP-11/10 Computer models.

Model NC-115 V, 47–63 Hz
Model ND-230 V, 47–63 Hz

These models are packaged in a 10-1/2 in. high mounting box. The prewired backplane can accommodate 16K of core memory, and the computers are normally supplied with 8K of core memory installed.

This supplement describes only the 10-1/2 in. mounting box and power system. These items are different than the corresponding items that are used in the original 5-1/4 in. high models.

The processor, memory, console and operating features are the same for both the 5-1/4 in. and 10-1/2 in. models. These items are discussed in the *PDP-11/05, 11/10 Computer Manual*, DEC-11-H05AA-B-D.

The 10-1/2 in. model is shipped with the revision M Data Paths Module (M7260). Revision M has a new oscillator and baud rate adjusting circuit. Refer to DEC-11-H05AA-B-D Supplement 2 entitled *Description of Data Paths Module M7260 Revision M* for the baud rate adjustment procedure for the Rev M module.

During subsequent operation in the field, if an earlier revision M7260 module is installed, use the baud rate adjustment procedure in the *PDP-11/05, 11/10 Computer Manual*, DEC-11-H05AA-B-D.

This supplement is divided into three chapters.

Chapter 1 Mounting Box
Chapter 2 Unpacking and Installation
Chapter 3 Power System

CHAPTER 1

MOUNTING BOX

1.1 INTRODUCTION

This chapter contains a detailed description of the mounting box (or chassis assembly) used for the PDP-11/05, 11/10 Models NC and ND. The same mounting box is used for both models except for the ac power line set which is wired for 115 V, 47–63 Hz for model NC and 230 V, 47–63 Hz for model ND.

1.2 OVERALL MECHANICAL DESCRIPTION

Figure 1-1 shows the PDP-11/05-NC Computer mounted in a cabinet. The console and top decorative panel (bezel) are attached to the mounting box with four screws each that are inserted from the rear side of the console and panel. The lower filler strip is similarly installed with two screws. The mounting screws are located along the vertical sides and are accessible when the computer is extended from the cabinet.

Figure 1-2 shows the computer fully extended from the rack and locked in the front down 90° position. The top and bottom mounting box covers have been removed. The power supply cover has been removed also. The top and bottom mounting box covers are each held in place with four Phillips pan-head screws (#6-32 × 0.37 in. long) and four #6 lock washers. The power supply cover is held in place with four Phillips pan-head screws (#10-32 × 0.31 in. long) and four #10 lock washers.

The interior of the mounting box is divided into three compartments. The smallest one extends partially across the front and contains the power distribution board and two fans for cooling the modules.

The power distribution board is secured to a mounting plate with two Phillips pan-head screws (#6-32 × 0.81 in. long) and two #6-32 nuts with integral lock washers. The mounting plate contains cutouts to accept the connectors on the power distribution board. The two logic fans have protective screens on the intake side. Each fan is mounted on the compartment partition with four Phillips pan-head screws (#6-32 × 0.62 in. long) and four #6 lock washers. The screws are secured by captive nuts on the fan. Intake air enters the compartment through slots on the left side, is forced over the modules, and exits through slots in the rear of the mounting box.

The next largest compartment extends from front to rear along the right side. This section contains the power supply that is installed as an assembly and is held in place by six Phillips pan-head screws (#10-32 × 0.31 in. long) and six #10 lock washers inserted through holes in the right side of the mounting box into nuts that are integral with the power supply chassis.

The largest compartment contains the pre-wired backplane, modules, and module guides. The basic computer contains a standard pre-wired 9-slot backplane installed pin side down next to the power supply. It is secured to both the front and rear mounting brackets by two Phillips pan-head screws (#10-32 × 1 in. long) and two #10 lock washers each that are inserted from the bottom through holes in the backplane frame (Figure 1-3). There is enough space to install one additional 9-slot backplane and one 4-slot backplane or three 4-slot backplanes.

Two rows of module guides are installed on mounting box brackets at the front and rear of the backplane compartment. The bottom row is slotted to guide the module into the slot for installation. The top row is slotted for the same reason but it also contains a steel rod that is circular in cross section. This rod engages the slotted arm of the pivoted handles on the hex-width module to provide the mechanical advantage required to properly seat and unseat the module.

The line set is attached to the rear of the mounting box (Figure 1-4) with two Phillips pan-head screws (#6-32 \times 0.19 in. long). Space is available in the rear of the mounting box for cable access. Three cable retainers are mounted on a bracket on the rear of the mounting box.

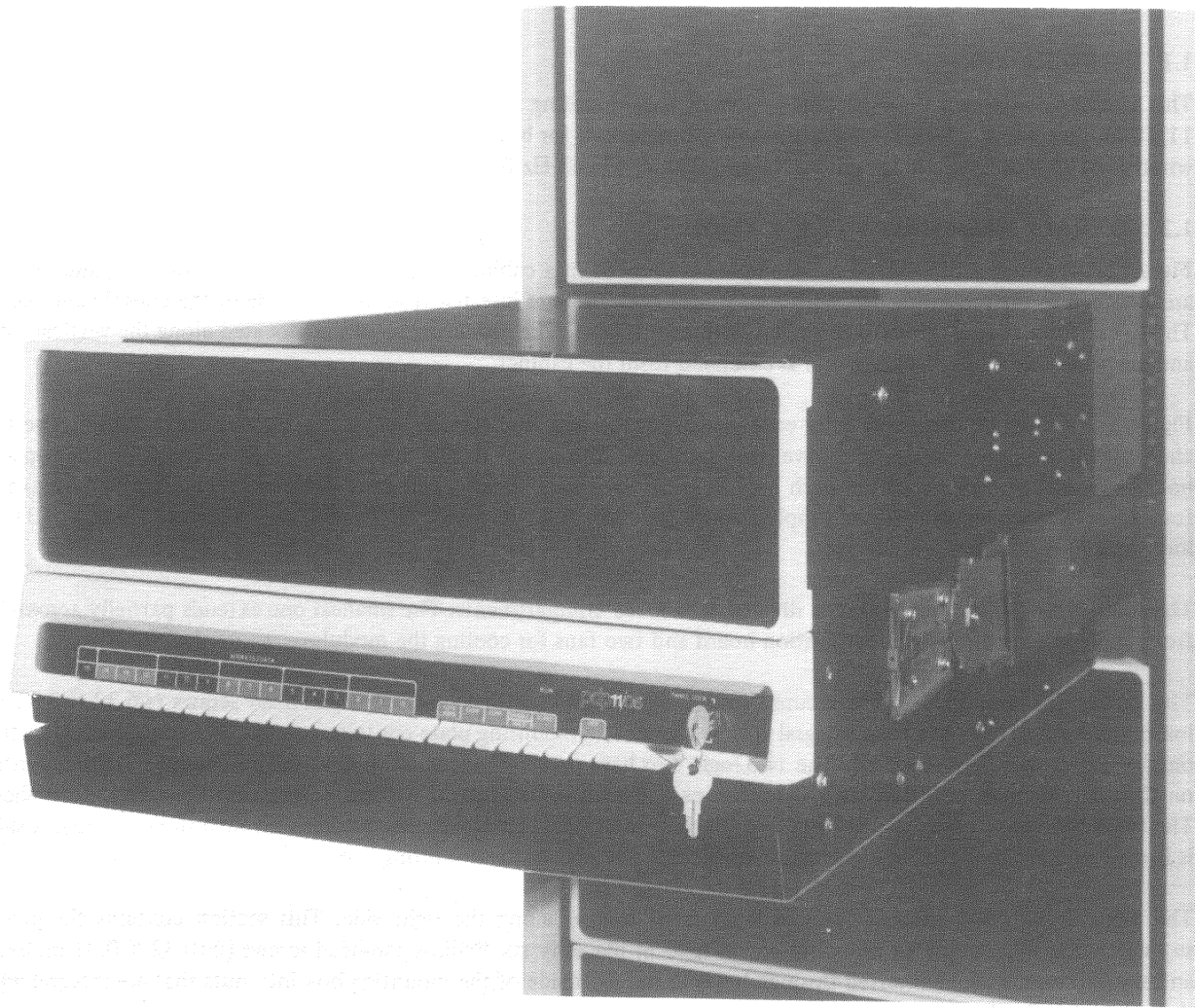

6601-2

Figure 1-1 PDP-11/05 NC Computer Mounted In Cabinet

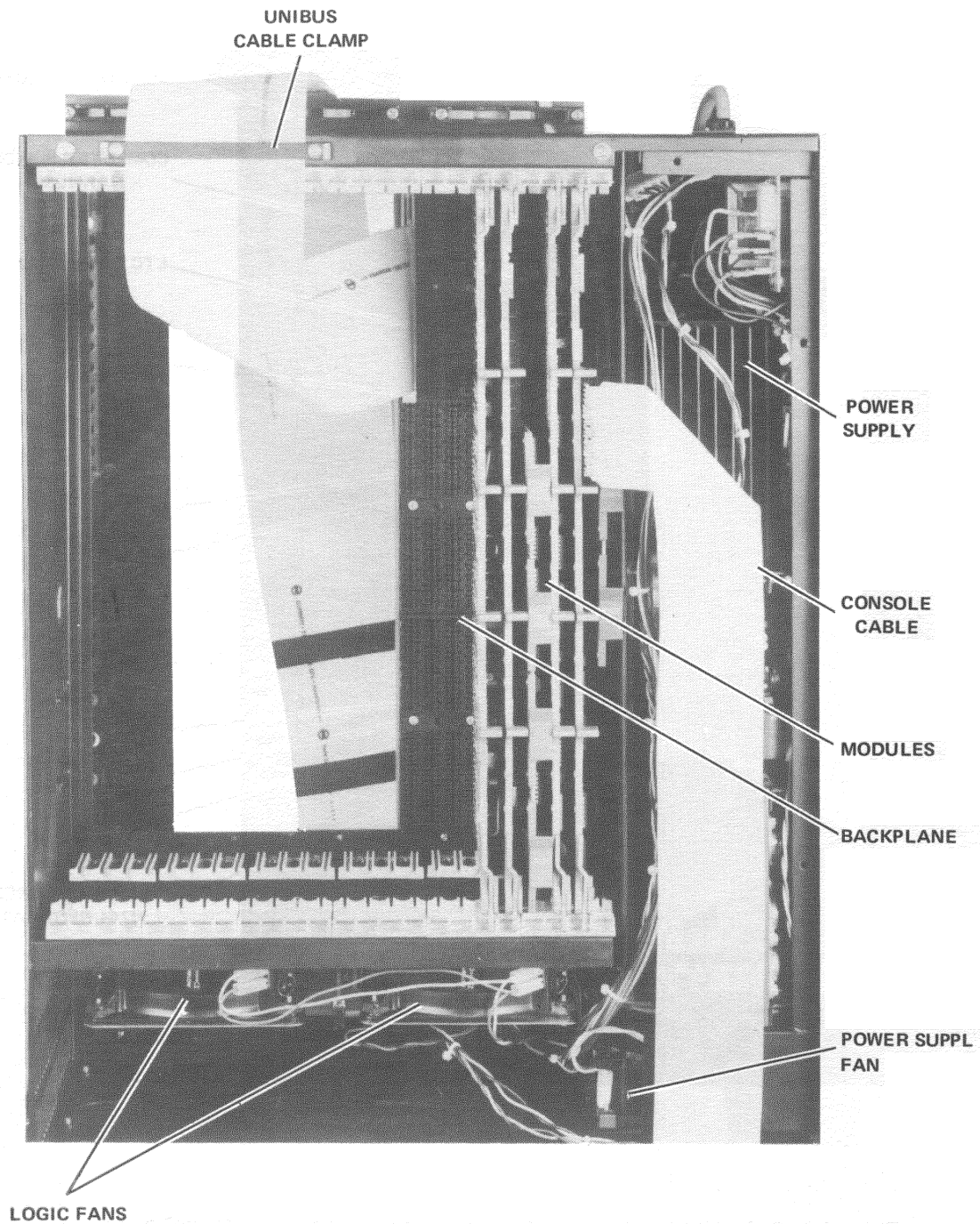

6699-6

Figure 1-2 PDP-11/05 NC Computer Extended and Locked In Front Down 90° Position

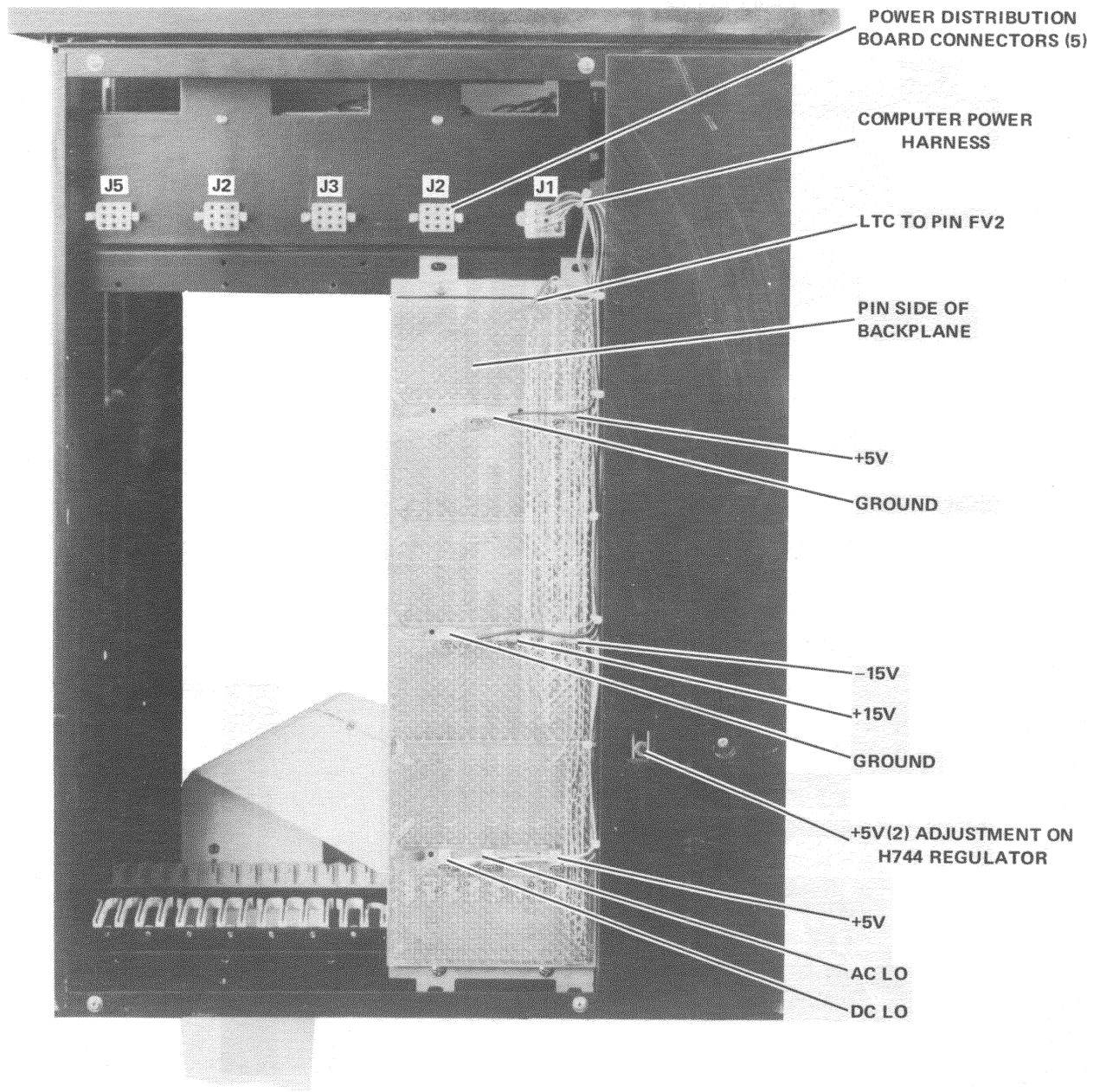

Figure 1-3 PDP-11/05 NC Computer Extended and Locked In Front Up 90° Position

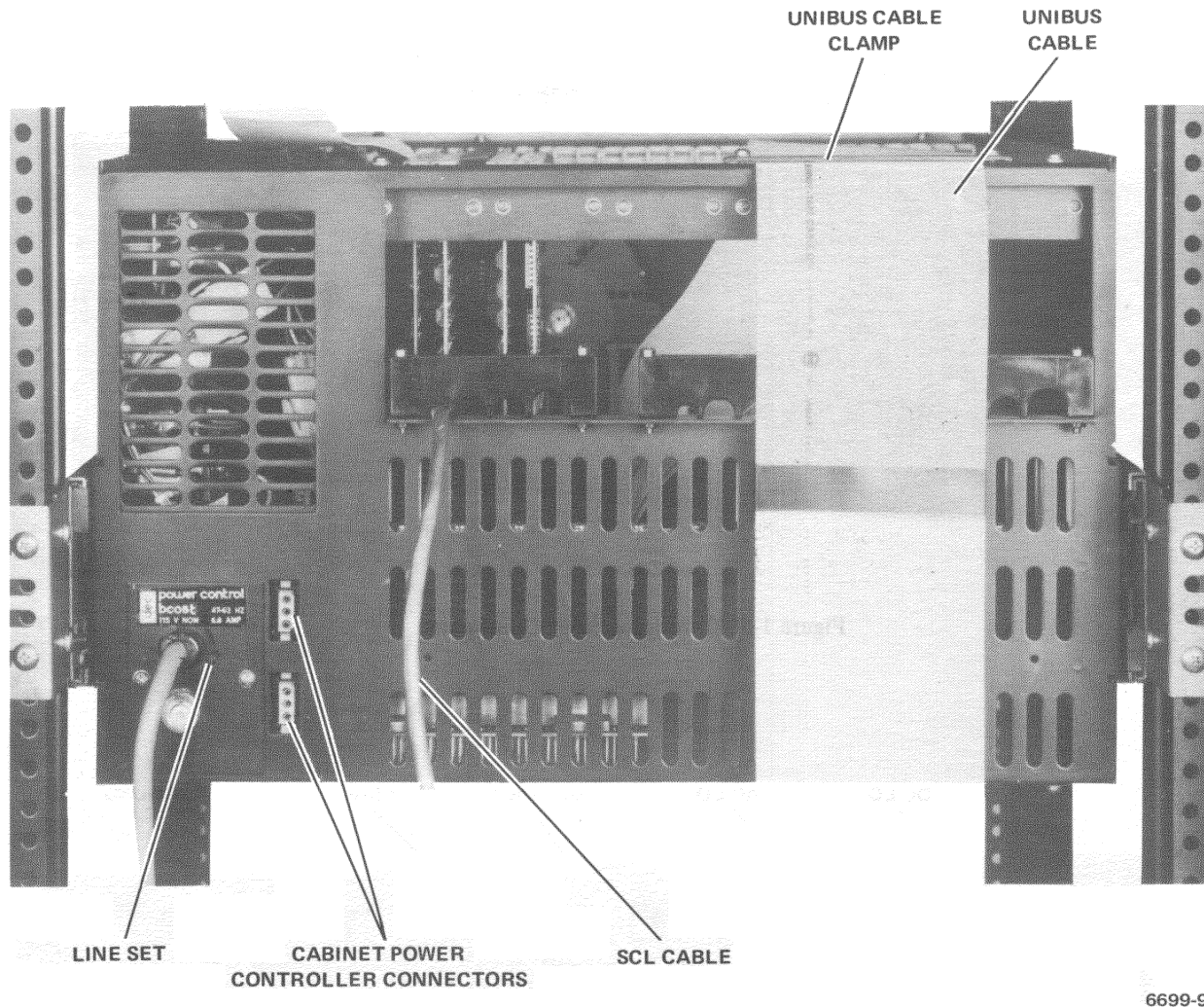
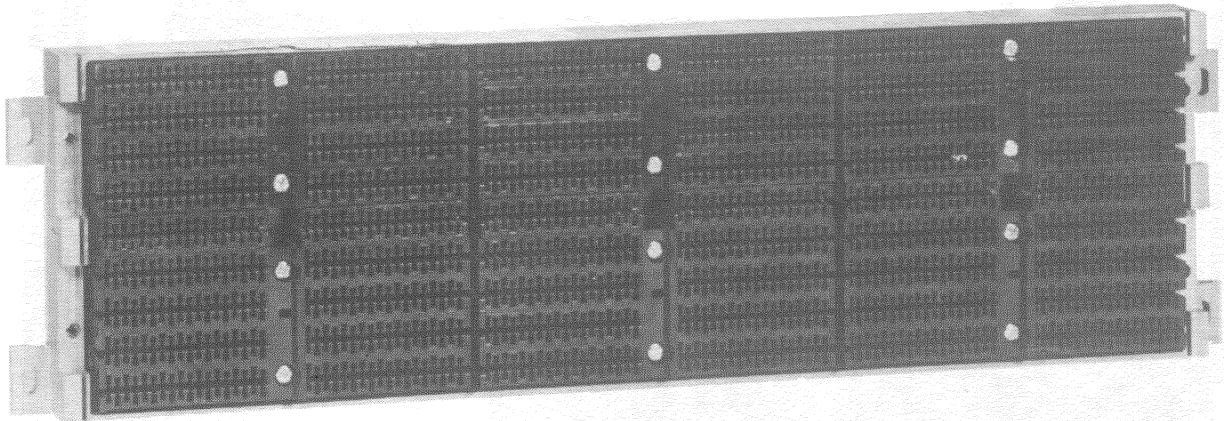

Figure 1-4 PDP-11/05 NC Computer, Rear View

1.3 BACKPLANE

The backplane is the connector assembly into which the modules are plugged. It consists of a group of molded connectors attached to a metal frame (Figure 1-5). One side provides slots with finger type contacts into which the modules are inserted. These contacts terminate in wire wrap pins on the other side of the backplane. The pins are inserted through and soldered to a printed circuit board that is part of the backplane. This board provides most backplane interconnections and the remaining interconnections are made by wire wrapping the pins (Figure 1-6). The printed circuit board also contains eight Faston tabs that mate with Faston connectors on the processor power distribution cable. This cable provides power, ground, and sensing signals from the power supply to the backplane. The cable also contains a slip-on connector that sends the line time clock (LTC) signal from the power supply to backplane pin F03V2.



6699-12

Figure 1-5 Connector Side of Backplane

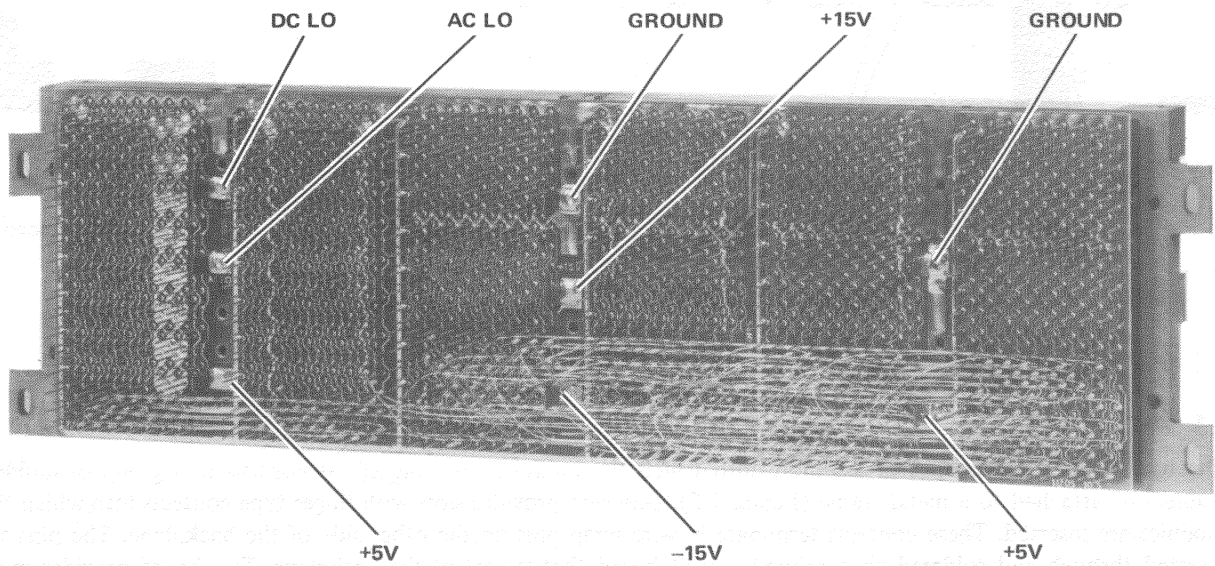

6699-3

Figure 1-6 Pin Side of Backplane

Figure 1-7 shows the backplane pin layout and method of identification. The slots are numbered 1 through 9 and the rows are lettered A through F. Each row is pinned to accommodate a single-height double-sided module edge-connector. The backplane accepts single, double, quad, and hex modules. A backplane pin is identified as follows:

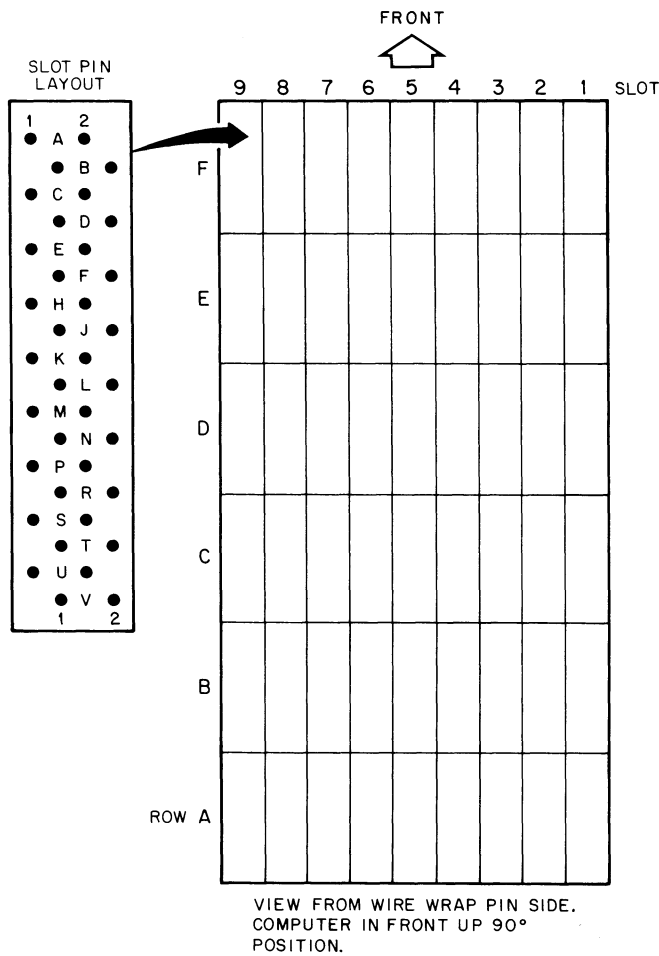
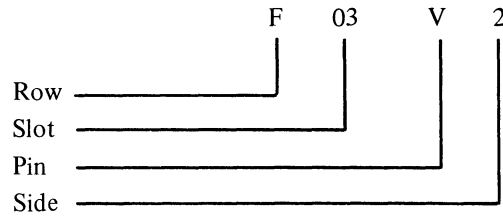

11-1873

Figure 1-7 Computer Backplane Connector and Pin Designations

Each module connector contains finger contacts on each side. Module contact designations are shown in Figure 1-8.

The backplane is pre-wired for the configuration shown in Figure 1-9. If an additional backplane is installed to accommodate additional memory or options, the M930 Unibus Terminator in slot A9-B9 must be removed and installed in the appropriate slot of the added backplane. In place of the M930 removed from slot A9-B9, an M920 Unibus Jumper module is installed to connect the Unibus signals to the added backplane. The M9970 Cable Connector module in slot C1-D1 contains a 40-pin Berg connector that accepts the connector on the serial communications line cable, which is used for the ASR-33, VT05, and serial model of the LA30. Slot A1-B1 is wired for a DF11 Communications Line Adapter that provides signal conditioning for communications devices using signals that are not TTL compatible. The DF11 works with the serial communications line interface so that when it is installed, the M9970 module is not used. Slots E1 and F1 are wired for the KM11 Maintenance modules that are used during troubleshooting operations. The core memory modules must be installed in the designated slots (Figure 1-9), but they are interchangeable.

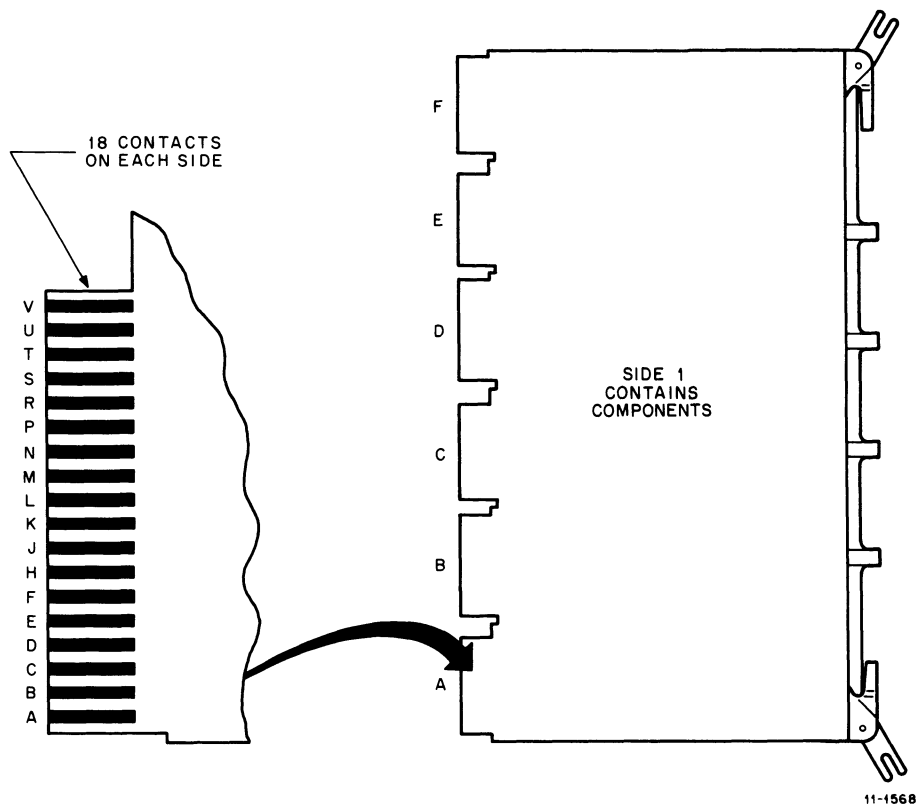

NOTES :

1. Side 1 is component side.
2. Each side contains 18 contacts that are designated A-V (omitting G, I, O, Q, W, X, Y, Z)
3. A complete designation contains a connector letter prefix, contact letter, and side suffix number. for example: AD2

Figure 1-8 Module Contact Designations

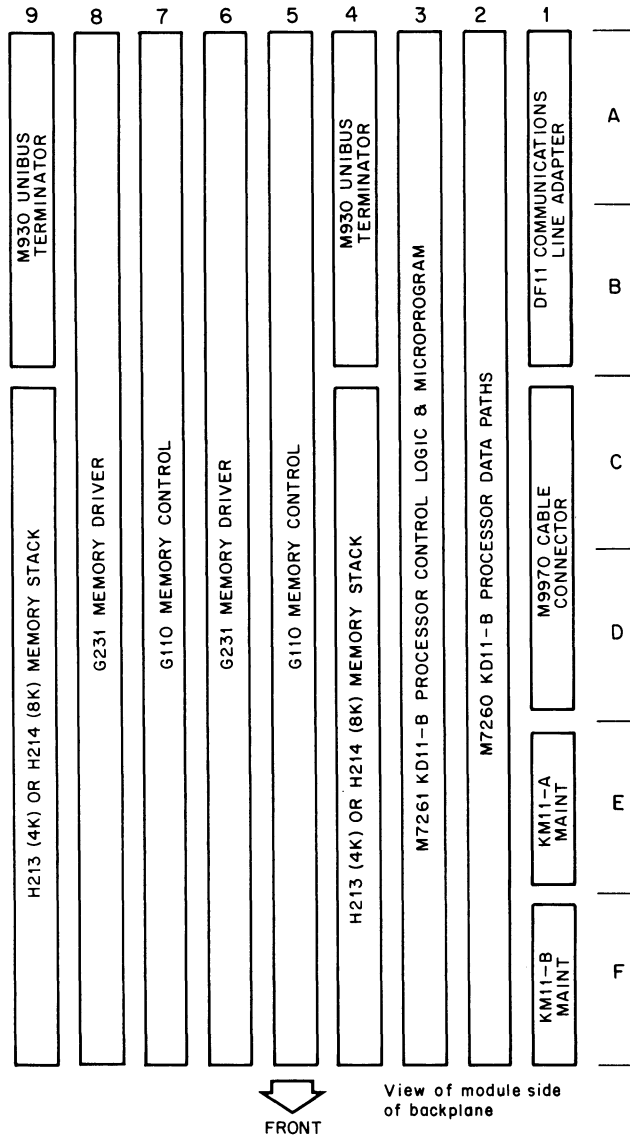

Figure 1-9 Module Utilization Diagram

1.4 POWER SYSTEM

The power system consists of the H750 power supply, BC05T/U line set, power supply wiring harness, power distribution wiring harness and board, and processor power harness.

The H750 Power Supply converts 115 V or 230 V, 47–63 Hz line voltage to regulated +5 V, +15 V and -15 V for the computer. The power supply also generates BUS AC LO L and BUS DC LO L, which are the power fail early warning signals and LTC L which is the real-time clock synchronizing signal.

The line set provides ac line power to the processor: BC05T is used for 115 V and BC05U is used for 230 V.

The power harnesses and distribution board interconnect the power supply, line set, cooling fans, and backplane.

A detailed discussion of the power system is given in Chapter 3.

CHAPTER 2

UNPACKING AND INSTALLATION

2.1 INTRODUCTION

This chapter provides information on the unpacking and installation of the computer. Information on installation certification and warranty service is also included.

2.2 UNPACKING

The computer is shipped ready to operate in a protective box (Figure 2-1) or mounted in a 19-in. cabinet. Remove the computer from the box and visually inspect for damage. Save the shipping carton and packaging materials in case it is necessary to return the computer for service. The slide mounts are attached to the computer, but the mounting screws are packed in a bag placed in the shipping container. Two console keys and a serial communications line (SCL) cable are also included. The keys are attached to the line cord at the rear of the computer. The standard SCL cable (70-08360) has a 40-pin Berg connector on one end that mates with the M9970 Cable Connector module. The other end has a Mate-N-Lok connector that mates to the one used on the LA30 DECwriter (serial model), DEC VT05 Alphanumeric CRT Display Terminal, and Teletype[®] Model 33 ASR. If the DF11 Communications Line Adapter is used instead of the M9970 module, the appropriate cable is included.

A computer shipped in a cabinet is locked in place to prevent movement during shipment. A shipping bracket is mounted on the back of the cabinet. The heads of two T-bolts are inserted in the cooling slots in the rear of the computer mounting box, and the heads are turned 90° so that they cannot be withdrawn. The bolt bodies protrude through holes in the shipping bracket and are secured to it by two nuts. Remove and retain the T-bolts and nuts for re-use if the cabinet is to be shipped or moved any distance.

2.3 INSTALLATION IN A CABINET

The slide assembly is installed on the computer. Unlock the slide release and remove the outer slide from each side of the computer. These are the fixed portions of the slide assembly and are mounted in the cabinets as follows.

The front of the fixed slide has an integral bracket and is mounted in the cabinet with two screws that are secured with captive nuts (Tinnerman nuts). The rear of the fixed slide is attached to a separate L-shaped bracket with two screws and nuts. The bracket is attached to the cabinet with two screws that are secured with captive nuts. Mount the fixed slides equidistant from and parallel to the floor.

Lift the computer and slide it carefully into the fixed guides until the slide release engages. Unlock the slide release and push the computer fully into the cabinet. Extend the computer enough to allow access to the front mounting screws. Slightly loosen the front and rear slide mounting screws and slide the computer back and forth. This allows the slides to assume a position that causes minimum binding. Retighten mounting screws.

[®] Teletype is a registered trademark of Teletype Corporation.

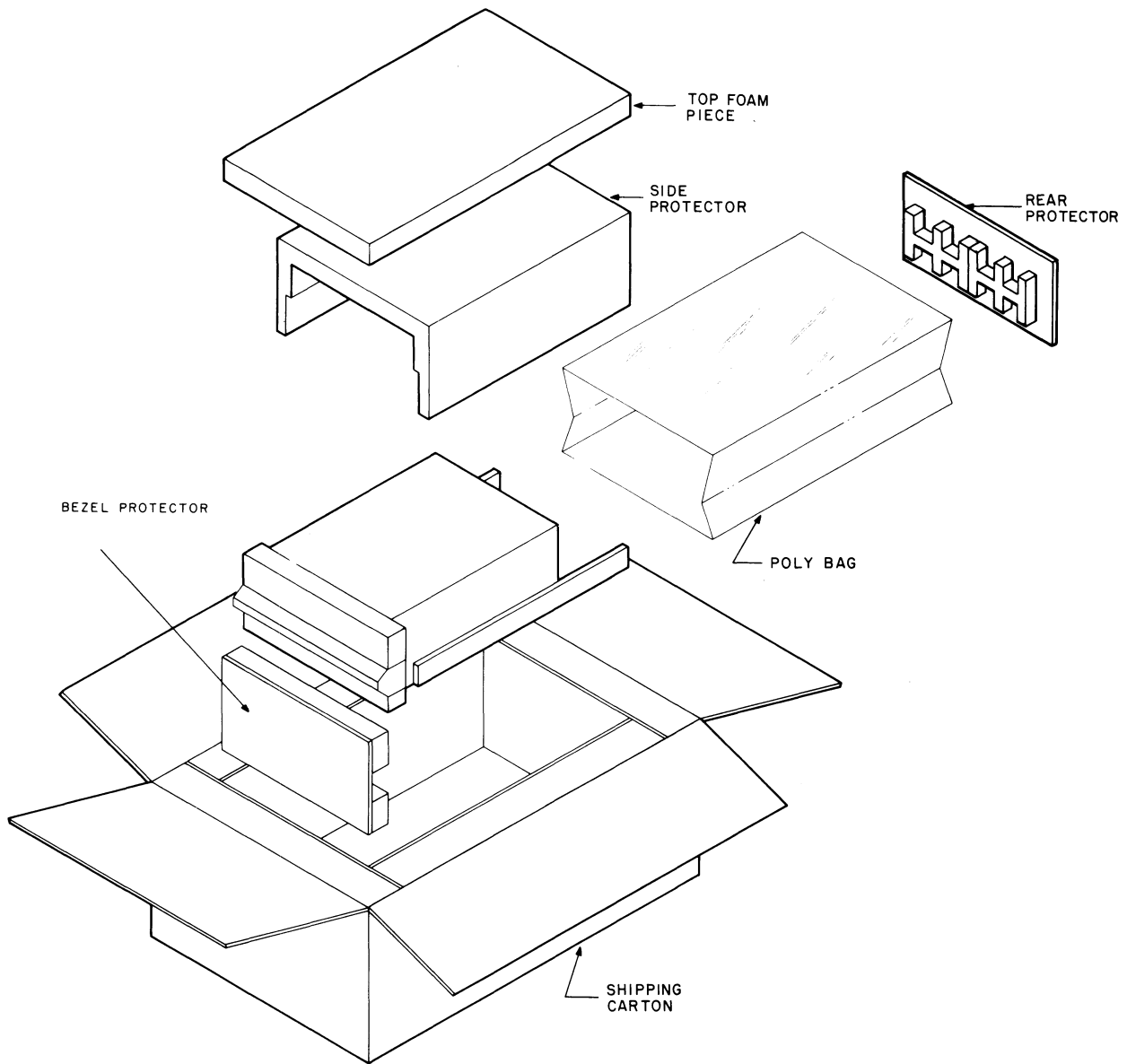

11-2139

Figure 2-1 Computer Packaging

2.4 INSTALLATION OF OPTIONS AND CABLES

The basic computer is shipped with a 9-slot backplane that accommodates the processor and 8K or 16K of core memory. Enough room remains to install three 4-slot backplanes or one 9-slot and one 4-slot backplane.

If options are purchased with the computer, they are installed in the mounting box, space permitting. Adjacent backplanes are interconnected with an M920 Unibus Jumper module.

2.4.1 Installing Options on Site

Remove the mounting box top and bottom covers. From the top, place the backplanes next to one another with connector row A at the rear of the box. From the bottom, secure the backplane to the mounting flange at the front and rear using four screws for the 9-slot version and two screws for the 4-slot version.

For each option, a power harness is used to connect the backplane to the power distribution board. All cables use identical Mate-N-Lok connectors to connect to the power distribution board. The other end of the cable terminates in Faston connectors or in a cable card, depending on the type of backplane. Faston connectors are used for a backplane that has its power connections brought out to Faston tabs on the pin side. Refer to the power harness drawing to identify the Faston connectors on the cable and slip them over the tabs on the backplane which are identified on the etched surface of the backplane.

If the backplane does not use Faston tabs, the other end of the power harness terminates in a cable card. Refer to the module utilization drawing for the option and insert the cable card in the designated slot in the connector side of the backplane.

The five connectors on the power distribution board are J1–J5, with J1 next to the power supply. Normally, the processor backplane is connected to J1, and J2 is not used. If this mounting box is used as an expansion box, J2 can be used because it is possible to install five 4-slot backplanes in an extension box.

If an MF11-L Memory is to be added, place it next to the processor backplane. Connect the MF11-L power harness (70-09206) to J3 on the power distribution board. If another 4-slot backplane is to be added, the box would be filled and the power harness for this backplane should be connected to J5. Connector J4 is not used because the MF11-L backplane takes the space of two 4-slot backplanes.

If three 4-slot backplanes are to be added, connect them to J3, J4, and J5. See Table 3-2 for option power harness part numbers.

CAUTION

1. **Memory interleaving is not allowed in the PDP-11/05.**
2. **MM11-E and F Memories must not be installed in the PDP-11/05 mounting box. Neither the H750 Power Supply in the PDP-11/05 nor the MM11-E and F Memories contain the DC LO circuit that cuts off -15 V to the memory during a power interruption to avoid destruction of store data. These memories must be installed in a box that is powered by an H720 Power Supply containing the DC LO circuit.**

The MM11-K and L Memories that are installed in the PDP-11/05 mounting box contain the DC LO circuit.

After the options are installed, use M920 Unibus Jumper modules to distribute the Unibus signals to all backplanes. Insert an M930 Unibus Terminator module in slots A4-B4 of the last backplane, if it is the last device connected to the processor.

A BC11-A Unibus cable is used to connect devices in another box to the processor. If the box contains only the processor backplane, install the Unibus cable rather than the M930 Terminator in slots A9-B9. If other options have been added, install the Unibus cable rather than the M930 Terminator in slots A4-B4 of the last backplane. Secure the Unibus cable in the strain relief clamp on the top rear surface of the mounting box (Figure 1-4). Remove the two screws that hold the Unibus cable clamp to the box. Place the cable between the box and the clamp, install the screws, and tighten loosely. Plug the cable into the backplane, leaving some slack, and tighten the screws.

Three strain relief clamps are provided on the top rear surface of the mounting box for I/O device cables.

2.4.2 Connecting the Serial Communications Device to the Processor

Connect the serial communications device (ASR 33, VT05, etc.) to the processor as follows:

1. Remove the M9970 Connector module from backplane slots C1-D1.
2. Plug the Berg connector on the 70-08360 SCL cable (supplied with the computer) into the Berg connector on the M9970.
3. Insert the M9970 into backplane slots C1-D1.
4. Connect the Mate-N-Lok connector on the SCL cable to the Mate-N-Lok connector on the cable that is attached to the serial communications device.
5. Place the SCL cable in one of the strain relief clamps.

2.5 AC POWER SUPPLY CONNECTION

Computers designed for use on 115-Vac circuits are equipped with a 3-prong connector, which, when inserted into a properly wired 115-Vac outlet, grounds the case of the computer. It is unsafe to operate the computer unless the case is grounded since normal leakage current from the power supply flows into metal parts of the chassis.

If the integrity of the ground circuit is questionable, the user is advised to measure the potential between the computer case and a known ground with an ac voltmeter.

2.5.1 Connecting to Voltages Other than 115 V

The computer operates at voltages ranging from 95 V to 135 V and from 190 V to 270 V (47 Hz – 63 Hz), providing the proper line set is attached to the computer. The plug is part of the line set. The plug configuration and specifications are shown in Figure 2-2.

On installation outside of the United States or where the National Electrical Code does not govern building wiring, the user is advised to proceed with caution.

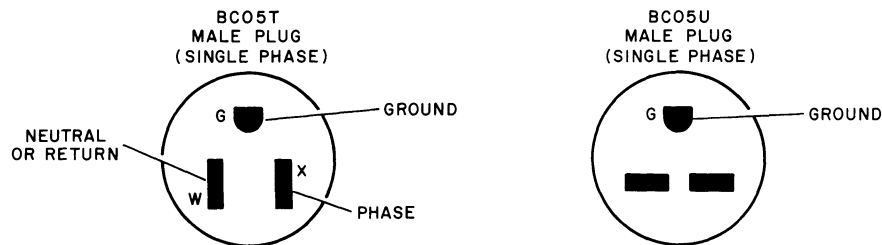

CONNECTOR SPECIFICATIONS

MODEL NUMBER	NEMA* CONFIGURATION	DESCRIPTION	POLES	WIRES	PLUG		RECEPTACLE	
					DEC PART NO.	HUBBEL	DEC PART NO.	HUBBEL
BC05T	5-15	115V, 15 AMP	2	3	90-08938	5266-C	12-05351	5262
BC05U	6-15	230V, 15 AMP	2	3	90-08853	5665-C	12-11204	5662

* ADD P SUFFIX FOR PLUG
ADD R SUFFIX FOR RECEPTACLE

11-1761

Figure 2-2 Connector Specifications for Line Set

2.5.2 Quality of AC Power Source

Computer systems consisting of the processor, memory, and peripherals are often sensitive to the interference present on some ac power lines. If a computer system is to be installed in an electrically noisy environment, it may be necessary to condition the ac power line. DEC Field Service Engineers can assist customers in determining if their ac line is satisfactory.

2.6 CABINET POWER CONTROL

2.6.1 Introduction

The PDP-11/05 and PDP-11/10 Computers have provisions to allow the console switch to control the operation of the cabinet mounted 860 or 861 Power Controller.

The computer is connected to the power controller via Mate-N-Lok connector J3 or J4, each of which is part of the power supply harness (H1). These connectors are mounted on the power supply chassis and are accessible at the rear of the computer (Figure 1-4). Two connectors are provided so that other devices in the cabinet can be connected in a daisy-chain manner to the power controller. A typical cabinet power control system wiring diagram using a PDP-11/05 and one power controller is shown in Figure 2-3.

When the PDP-11/05 console switch is in the POWER or PANEL LOCK positions, the power controller is activated and power is supplied to all devices in the cabinet. In multi-cabinet systems, appropriately wired power controllers in the additional cabinets are activated when the PDP-11/05 console switch is in the POWER or PANEL LOCK positions.

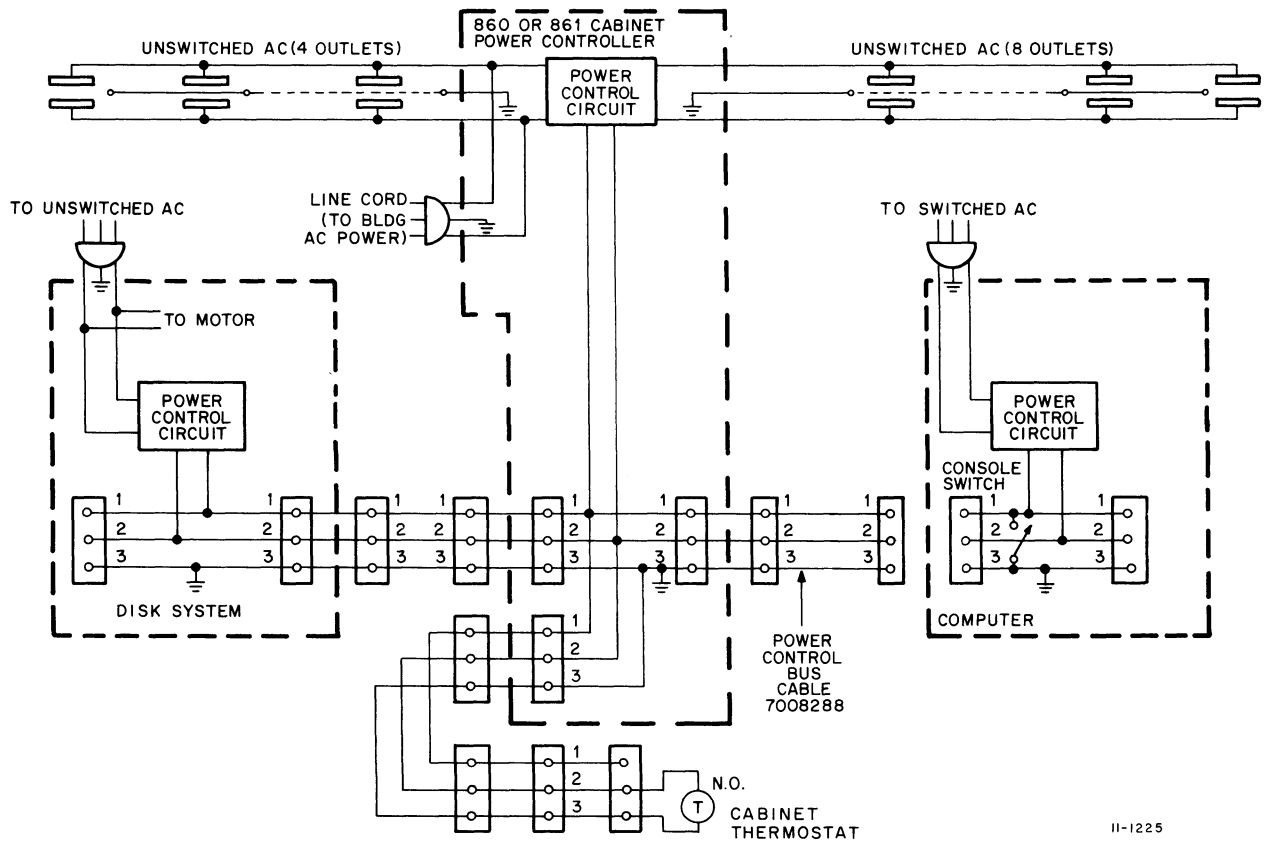

Figure 2-3 Typical Cabinet Power Control System Wiring Diagram

The power controller provides eight switched power outlets and four unswitched outlets. The 860 controller outputs are available at two connector strips installed in the cabinet. The 861 controller outputs are installed in the controller front panel.

Functionally, both the 860 and 861 operate in the same way. A 3-wire cable is used to interconnect power controllers, computer, and other peripherals in a system. Line 1 is a POWER REQUEST, Line 2 is EMERGENCY SHUTDOWN, and Line 3 is SIGNAL RETURN (ground). Line 2 is connected to Line 3 through a thermostat, mounted on the controller. The controller LOCAL/OFF/REMOTE switch is placed in the REMOTE position for this application. Placing the PDP-11/05 console in the POWER or PANEL LOCK position, connects lines 1 and 3 which energizes the power controller and supplies ac power to the system. If an overtemperature occurs in a cabinet, the thermostat closes, connecting lines 2 and 3, and disables the switched outlets of all controllers in the system. The unswitched outlets are not affected. Refer to the *861-A,B,C Power Controller Maintenance Manual* DEC-00-H861A-A-D, for additional information.

2.6.2 Typical Multi-Cabinet Installation

Figure 2-4 shows a typical multi-cabinet installation. Specifically, it shows the interconnection of the PDP-11/05 Computer, three power controllers, and three model H720 E/F Power Supplies in a three-cabinet system. The interconnection is identical for model 860 or 861 Power Controllers.

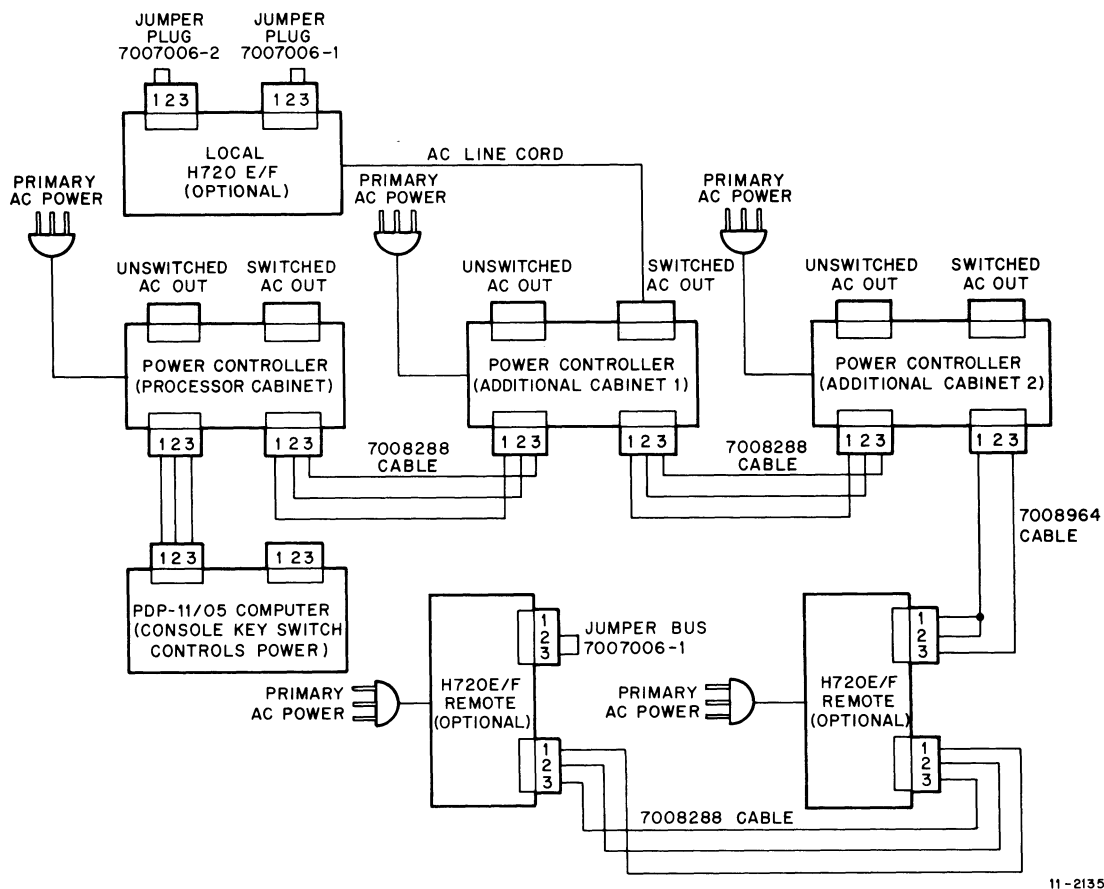

11-2135

Figure 2-4 Interconnection of Power Controllers in Multi Cabinet Installation

The 3-wire cable (7008288) that is used to interconnect the power controllers and computer allows the controllers to be operated in the local or remote mode and permits switched power to be shut off if any power controller overtemperature switch is activated.

In this example, each power controller should have its LOCAL/OFF/REMOTE switch in the REMOTE position in order to respond to the computer key switch. Placing the computer key switch in the POWER or PANEL LOCK position, with the power controller switch in the REMOTE position, energizes the controller and supplies ac power to the switched outputs. If the power controller switch is placed in the LOCAL position, ac power is supplied to the switched outputs and the computer key switch does not affect controller operation. Individual cabinets can be turned on and off using the LOCAL switch position, which is convenient during system troubleshooting. Power is supplied to the unswitched outputs in the LOCAL or REMOTE switch positions as long as the controller circuit breaker is on.

Figure 2-4 shows two methods of supplying power to options that use H720 E/F type power supplies.

The first, or local method, relates to the H720 E/F that is connected to the power controller in additional cabinet 1. The power controller interconnection cable is not used: jumper plugs 7007006-1 and 7007006-2 are installed in the two unused connectors. The ac line cord for the H720 E/F is plugged into the power controller switched ac outlet. The H720 E/F REMOTE/LOCAL switch is placed in the LOCAL position. This power supply is turned on when the computer key switch is placed in the POWER or PANEL LOCK position.

The second, or remote method, relates to the two H720 E/F Power Supplies associated with the power controller in additional cabinet 2. Both supplies are daisy-chained to the controller using the interconnecting cable. The first H720 E/F is connected to the controller with 2-wire cable 7008964. In turn, it is connected to the second H720 E/F with 3-wire cable 7008288. This power supply has jumper 7007006-1 installed in the unused connector. Both H720 E/F REMOTE/LOCAL switches are placed in the REMOTE position, and both ac power cords are plugged into wall outlets. These supplies are turned on when the computer key switch is placed in the POWER or PANEL LOCK position. Each H720 E/F can be turned on individually with the computer key switch OFF by placing the power supply switch in the LOCAL position.

2.7 INSTALLATION CERTIFICATION

Once the computer has been installed, it is strongly recommended that a system diagnostic be run to ensure that the equipment operates correctly and that installation has been properly performed. Because system configurations widely vary, no one diagnostic will completely exercise all the attached devices.

The *MAINDEC User's Manual* that comes with the diagnostic package should be consulted for the appropriate diagnostic to be run, depending upon the attached devices. The *MAINDEC User's Manual* lists the devices that each diagnostic will exercise. The three system exercisers presently available are T17 System Exerciser (MAINDEC-11-DZQKB) for relatively small systems, General Test Program (MAINDEC-11-DZQGA) for medium to large systems, and Communications Test Program (MAINDEC-11-DZQCA) for communications-oriented systems. At least one of the above diagnostics and, if appropriate, the other two, should be used to verify system operation.

Once the diagnostic is selected, the respective diagnostic write-up should be consulted for specific operating instructions. If the user is not familiar with console operation and/or procedures for loading paper tapes, he should read Chapter 4 of the *PDP-11/05, 11/10 Computer Manual*, DEC-11-H05AA-B-D.

2.8 WARRANTY SERVICE (DOMESTIC ONLY)

The PDP-11/05 Computer is sold with the 30 day, return-to-factory warranty. If the computer warranty period has expired or it is covered by on-site warranty, the local DEC field service office should be contacted. If the computer is still covered by the 30 day, return-to-factory warranty, and factory service is required, the following procedure should be used.

1. Call the Maynard, Massachusetts Repair Depot, Telephone 617-897-5111, X4079 or X2135.
2. The caller will receive a return authorization (RA) number that must appear on the shipping label of the returned package. Do not return equipment for repair unless it has an assigned RA number.
3. Package the computer in a shipping container equivalent to the one that it arrived in. Use the original shipping container, if possible.
4. Send the computer to the following address:

Digital Equipment Corporation
146 Main Street
Maynard, Massachusetts 01754
Attn: Depot Repair, Bldg. 8-2
RA #XXXX

The PDP-11/10 Computer is sold with the 90 day, on-site warranty. Call the local DEC field service office if service is desired.

CHAPTER 3

POWER SYSTEM

3.1 INTRODUCTION

This chapter provides a mechanical description of the power system that consists of the H750 Power Supply, BC05T/U line set, and three wiring harnesses. A system functional description and detailed electrical interconnection diagram is included.

The regulator circuits are discussed in detail. Regulator maintenance and troubleshooting information is included also.

3.2 MECHANICAL DESCRIPTION

3.2.1 Power Supply

The power supply consists of three transformers (T1, T2, T3), dc regulator (PS1), +5 V regulator (PS2), relay (K1), diode board (PS3), terminal board (TB1), and fan mounted in a sheet metal chassis (Figures 3-1 and 3-2).

The chassis is rectangular in shape and measures approximately 22 in. long by 9-1/2 in. high by 5 in. wide. The top and left side are open and all the components are mounted on the solid bottom and right side. The main structural member is the mounting plate that is a single piece of sheet metal bent to form the right side and bottom of the chassis. Two end pieces are welded to the mounting plate. Component mounting is facilitated by threaded inserts that are installed in integral brackets and by holes in the right side and bottom of the chassis. The front cover has a cutout for the fan and holes for the fan mounting screws. The rear cover has cutouts for the line set and two Mate-N-Lok connectors. Several holes in this cover allow air to be drawn in by the fan to cool the power supply.

The power supply components are mounted as follows.

The dc regulator (PS1) is attached to six integral brackets on the side of the chassis with six Phillips pan-head screws (#6-32 × 1/2 in. long) and #6 lock washers. The regulator is installed with the heat sink facing inward. The screws pass through holes in the board and are threaded into inserts in the brackets.

The additional +5 V regulator (PS2) is attached to the side of the chassis with four Phillips pan-head screws (#4-40 × 5/16 in. long) and four #4 lock washers. The screws pass through holes in the chassis and are threaded into four standoffs (#4-40 × 3/4 in. long) that are attached to the +5 V regulator mounting bracket.

The diode board (PS3) is attached to the side of the chassis with two Phillips truss-head screws (#6-32 × 3/8 in. long) and two #6 lock washers. The screws pass through holes in the chassis and are threaded into two standoffs (#6-32 × 3/4 in. long) that are attached to the diode board.

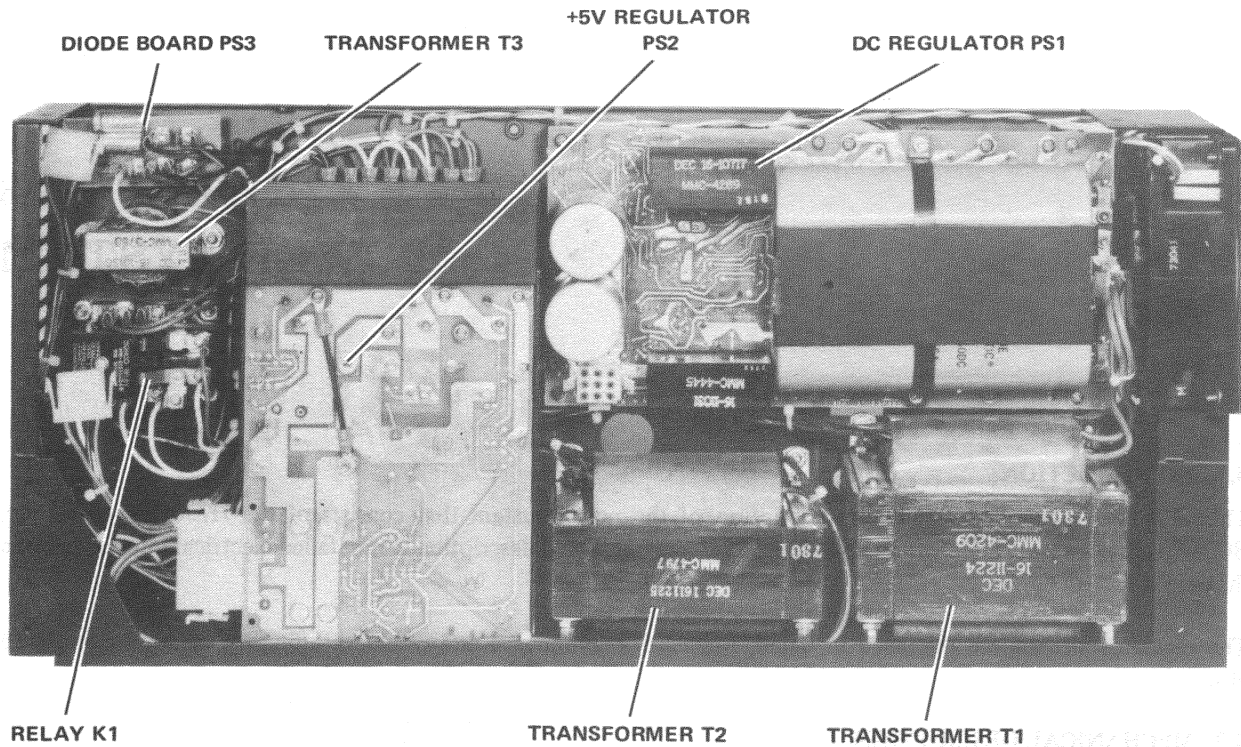

6699-8

Figure 3-1 Power Supply Side View

Relay K1 is attached to the side of the chassis with four Phillips truss-head screws (#8-32 X 5/8 in. long) and four #8-32 Kep nuts that have integral lock washers.

Transformers T1 and T2 are attached identically to the side and bottom of the chassis. Each transformer is attached to the bottom of the chassis by four Phillips flat-head screws (#8-32 X 1/4 in. long). The screws pass through dimpled holes in the chassis and are threaded into #8-32 standoffs that are attached to the transformer. Each transformer is attached to the side of the chassis at its top and bottom. At the top, the attachment is made with two Phillips truss-head screws (#10-32 X 7/16 in. long) that pass through holes in the chassis and transformer bracket and are secured by two #10-32 Kep nuts. These nuts are accessible inside the chassis. At the bottom, the attachment is made by two identical screws; however, they are threaded into two #10-32 U-shaped, self-retaining speed nuts (Tinnerman nuts) attached to the transformer bracket. Tinnerman nuts are used because these attaching points are not accessible from inside the chassis.

Transformer T3 is attached with two Phillips truss-head screws (#8-32 X 3/8 in. long) that pass through holes in the chassis and transformer bracket and are secured by two #8-32 Kep nuts.

Terminal block TB1 is attached to the side of the chassis with two each Phillips pan-head screws (#6-32 X 5/8 in. long), #6 lock washers, and #6-32 Kep nuts.

The fan is attached to the front end of the chassis with four Phillips pan-head screws (#6-32 X 5/8 in. long) and four #6 lock washers. The screws pass through holes in the chassis and are secured by self-retaining nuts on the fan.

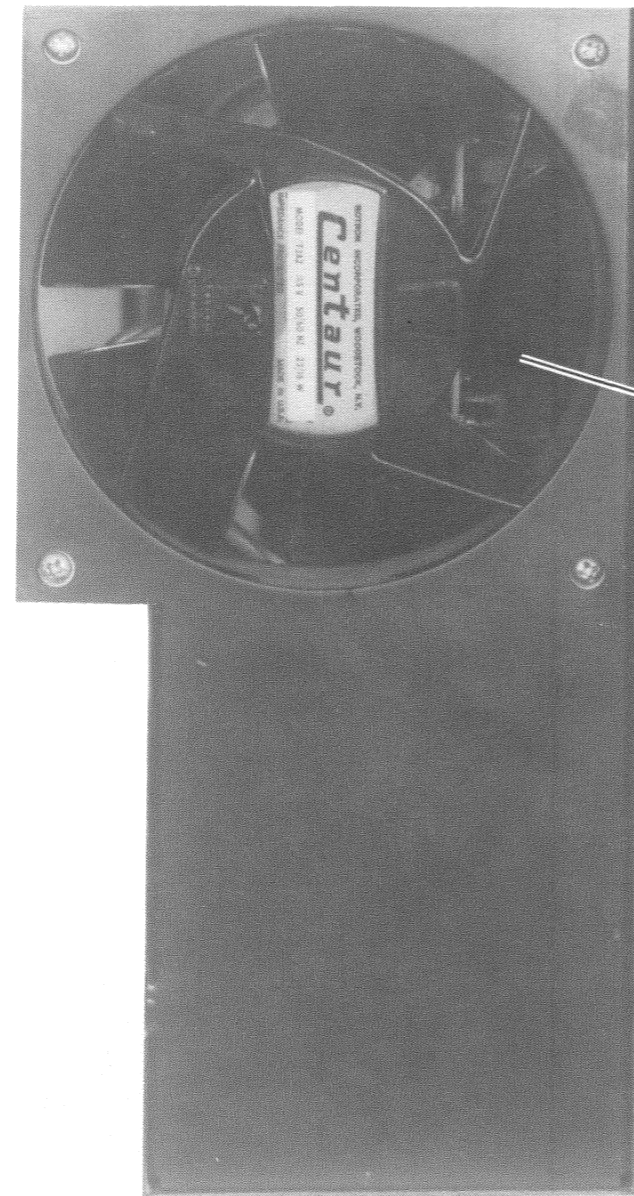

POWER
SUPPLY FAN

REAR

6699-2

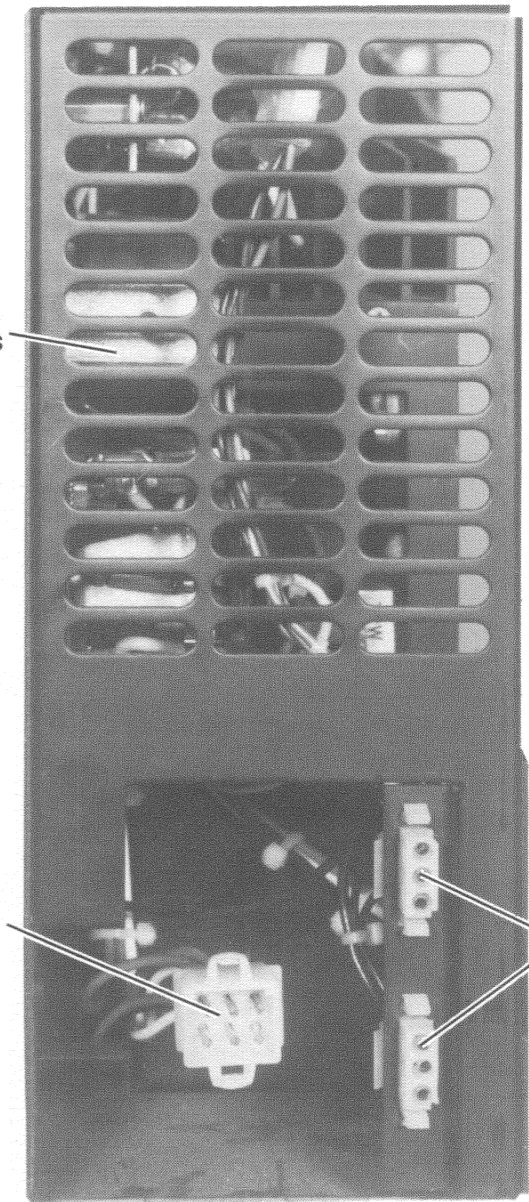

COOLING
AIR SLOTS

CONNECTOR H1-P1
TO LINE SET

CONNECTORS
H1-J3 AND
H1-J4 (TOP)
TO CABINET
POWER
CONTROLLER

FRONT

6699-5

Figure 3-2 Power Supply, Front and Rear Views

3.2.1.1 DC Regulator – The 5409728 dc regulator (Figures 3-3 and 3-4) consists of a printed circuit board, heat sink, discrete electronic components, thermostat with cable connector, ac input and dc output connectors, and attaching hardware.

Current shipments use regulator 5409728-0-0, J revision that is discussed in this manual. Earlier revisions differ in component values and current ratings. Engineering drawings applicable to the module used are shipped with the equipment. These drawings include a schematic of the dc regulator module that shows component values and part numbers.

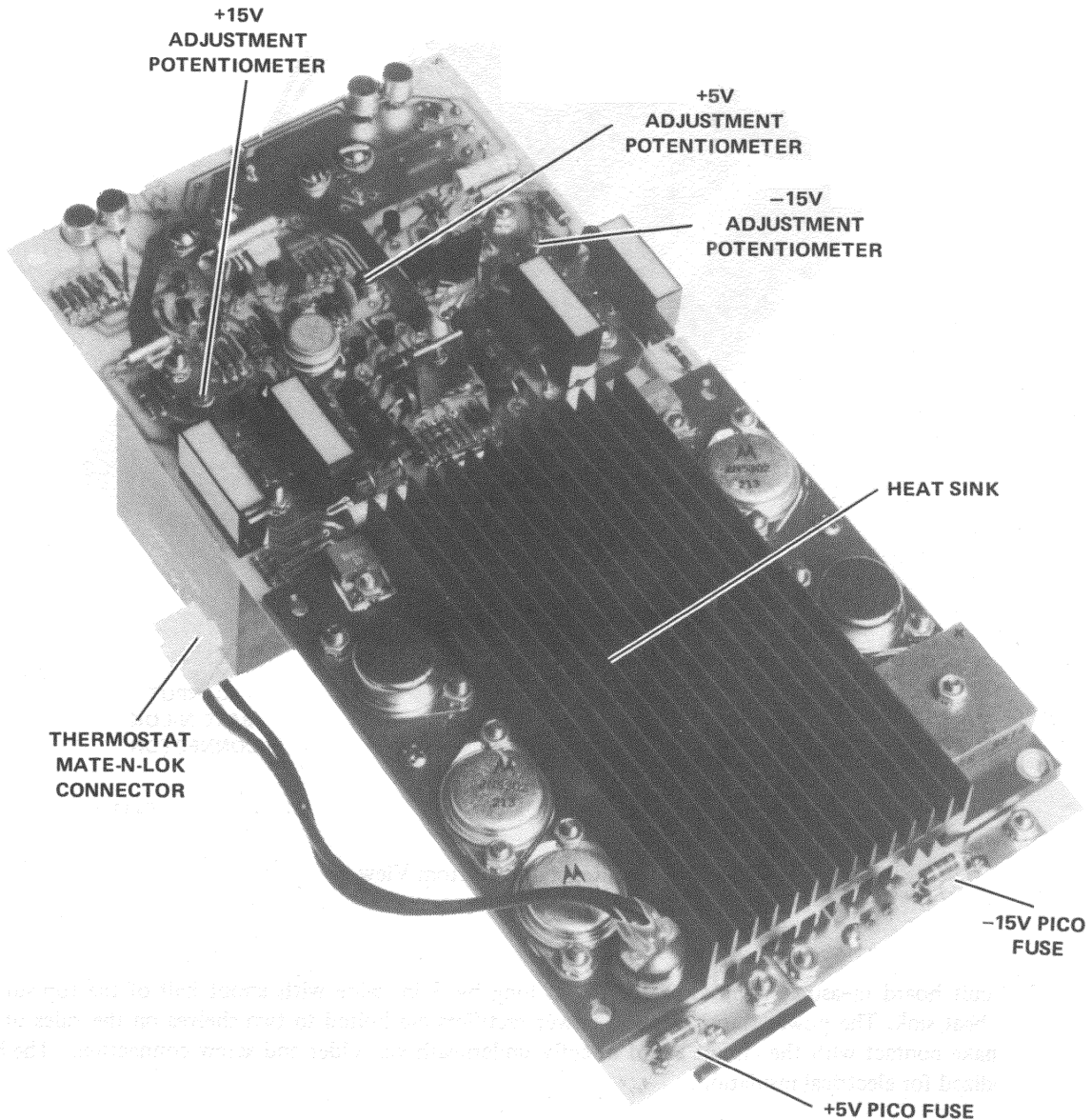

6211-2

Figure 3-3 DC Regulator, Top View

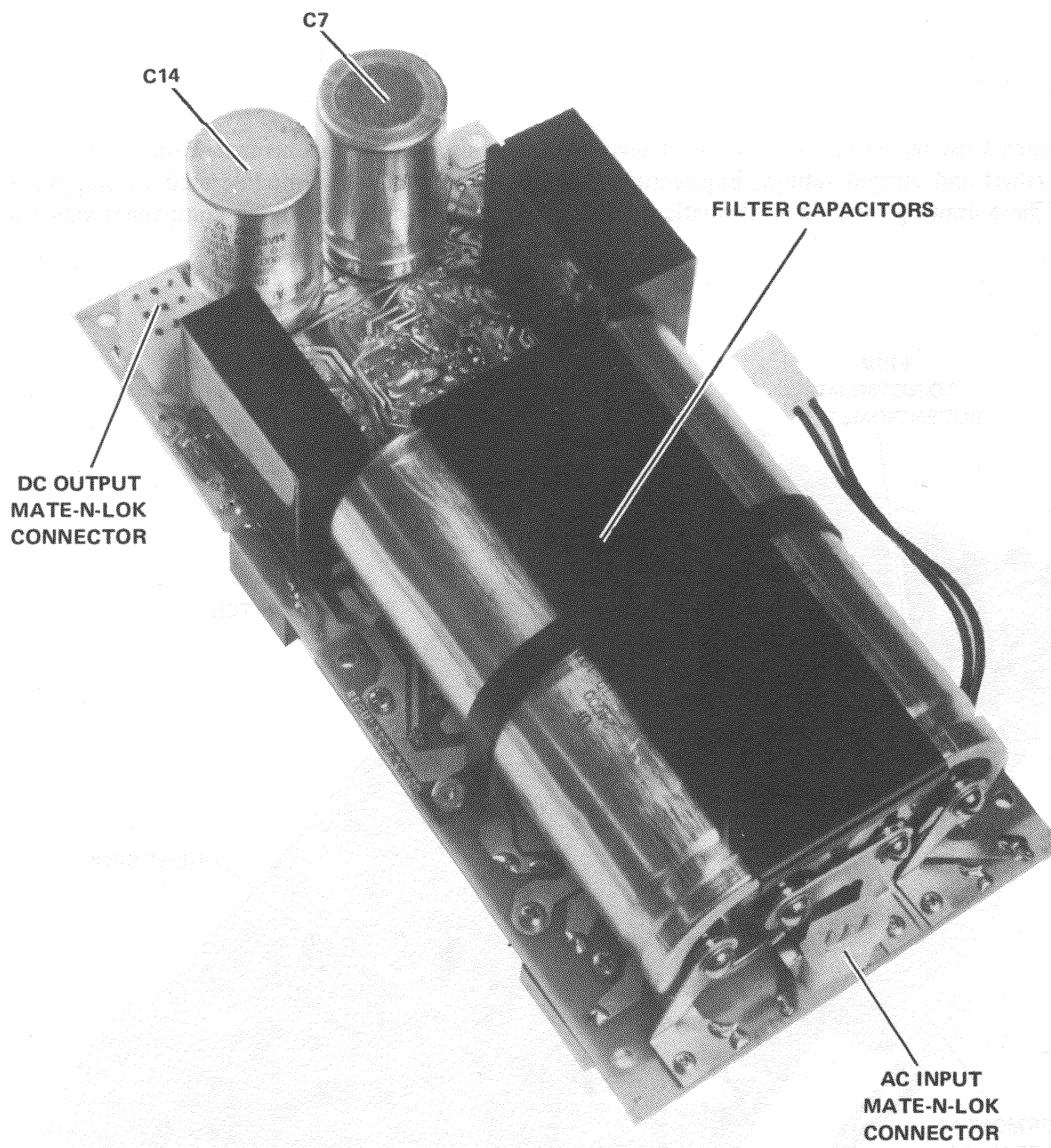

6211-1

Figure 3-4 DC Regulator, Bottom View

The printed circuit board measures approximately 10 in. long by 5 in. wide with about half of the top surface devoted to the heat sink. The power transistors and power rectifiers are bolted to two shelves on the sides of the heat sink and make contact with the circuit board directly underneath via solder and screw connections. The heat sink is hard anodized for electrical insulation.

The other half of the top surface is devoted to interconnecting and mounting the balance of the circuit components. Three output voltage adjustment potentiometers (+5 V, +15 V and -15 V) are accessible on the top surface of the board.

Two small Pico TM fuses are soldered to split lug terminals on the fan end of the PC board. These fast-acting fuses blow only when some component is defective or when the +5 V or -V is too high. The two input filter capacitors are held to the underside of the board by a bracket and are connected to the circuit via jumper tabs on the fan end.

The +5 V and -15 V output filter capacitors and inductors are mounted on the bottom surface of the board. The capacitors (C7 and C14) are attached with screws that are threaded into the capacitor terminals. The inductors (L1 and L2) are attached with integral terminal studs that pass through the board and are secured by Kep nuts.

3.2.1.2 +5 V Regulator – The H744 +5 V Regulator (Figures 3-5 and 3-6) consists of a printed circuit board, heat sink, discrete electronic components, input/output connector, and attaching hardware mounted on a sheet metal bracket.

The main structural member is a U-shaped sheet metal bracket that measures approximately 8 in. high \times 5-1/4 in. wide \times 2-3/4 in. deep. The heat sink is mounted in the open top of the bracket with its cooling fins facing outward and component mounting surface facing inward. It is held by two screws on each side that pass through holes in the bracket and are threaded into holes in the heat sink.

The printed circuit board is mounted with its component side facing inward on the rear of the bracket. It is mounted on two corner lugs on the lower edge of the bracket by two screws that pass through the board and are threaded into inserts in the lugs. The top of the board is attached to the rear side of the heat sink by the same hardware that is used to attach the transistor (Q2) and diodes (D4 and D5) to the top side of the heat sink. The large input filter capacitor (C1) is retained in an L-shaped holder that is attached to the bottom and left side of the bracket with two screws. The capacitor is electrically connected by two straps that are secured to the capacitor terminals with screws and are soldered to the printed circuit board. Output capacitors (C8 and C9) are mechanically and electrically connected to the printed circuit board with screws. The output inductor (L1) is mechanically and electrically connected to the printed circuit board with integral terminal studs that pass through the board and are secured by Kep nuts.

The input/output Mate-N-Lok connector is attached to the bottom right side of the board and is accessible through a hole in the side of the bracket.

A small notch in the bottom of the bracket provides access to the voltage adjustment potentiometer.

A clear plastic cover is mounted on four mounting lugs on the front of the bracket. It is held by four standoffs that have male threads on one end to attach the cover and female threads on the other end by which the regulator is mounted to the power supply chassis.

3.2.2 Line Set

The line set consists of a BC05T (115 V) or BC05U (230 V) ac power cord installed in and wired to an ac input box (drawing C-UA-BC05T-0-0 or C-UA-BC05U-0-0). The box is a U-shaped sheet metal bracket with a slide-on cover that is locked in place with one screw (Figures 3-7 and 3-8). The box contains a circuit breaker, printed circuit board, RFI dual-disc ceramic capacitor, and a 6-socket Mate-N-Lok connector. The circuit breaker is mounted on one end of the box so that the reset button is accessible when the line set is installed in the computer. The printed circuit board is mounted on the circuit breaker terminals with two screws to provide the electrical interconnection for the circuit breaker. The board is used to mount and interconnect the RFI capacitor, Mate-N-Lok connector, and Faston tab connectors for the ac power cord. The phase (black) and neutral (white) wires of the ac power cord are connected directly to the Faston tabs on the printed circuit board. The ground (green) wire of the ac power cord is connected to a dual Faston tab on the bracket and then to the Faston tab on the printed circuit board.

The 115 V and 230 V models differ in two respects: breaker current rating (10 A for 115 V and 5 A for 230 V) and the layout of the printed circuit jumpers for connection to the transformers.

TMPico is a trademark of Littlefuse Electrical Supply.

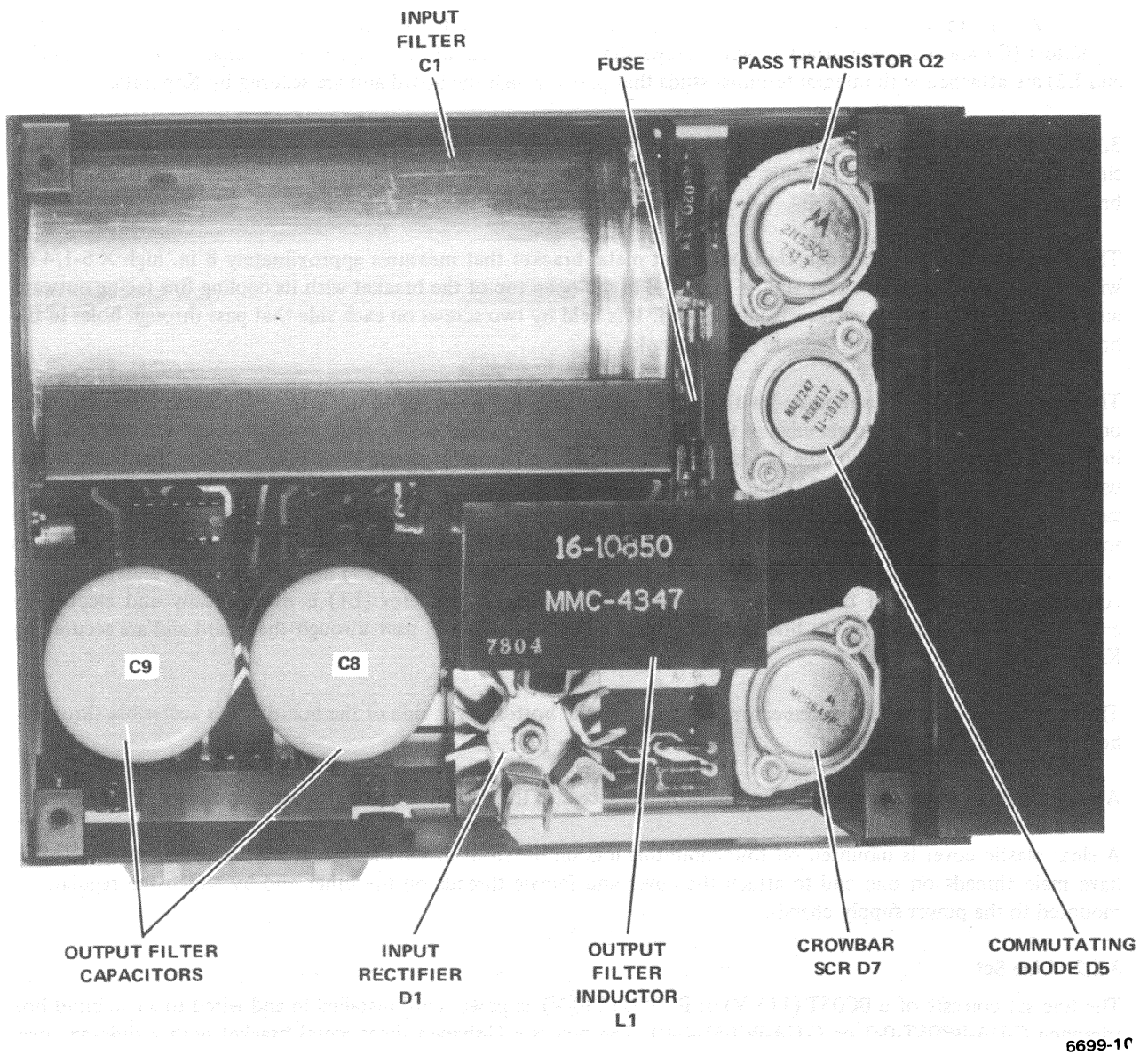
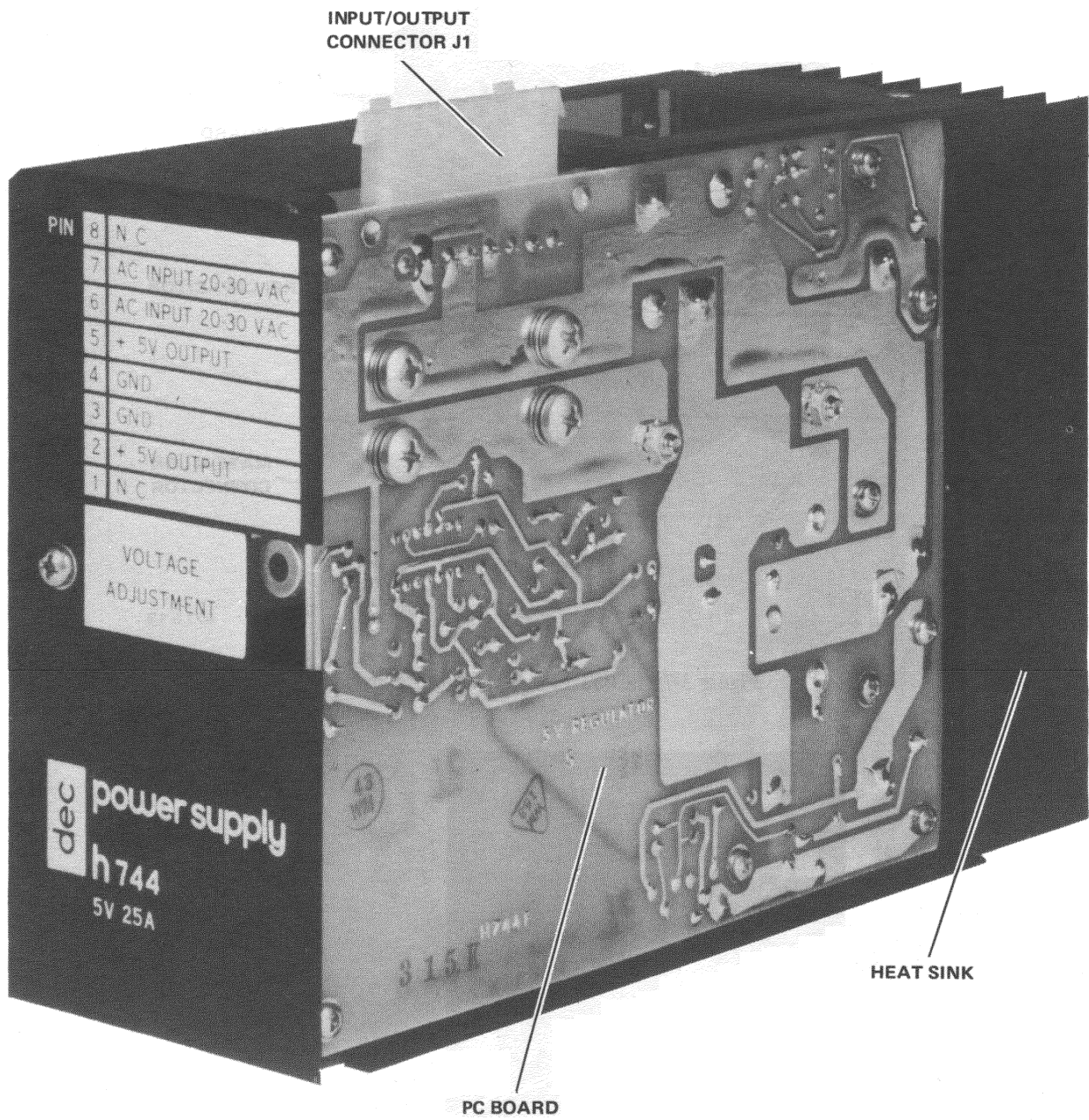

Figure 3-5 +5 V Regulator, Side View



6699-7

Figure 3-6 +5 V Regulator, 3/4 Bottom View

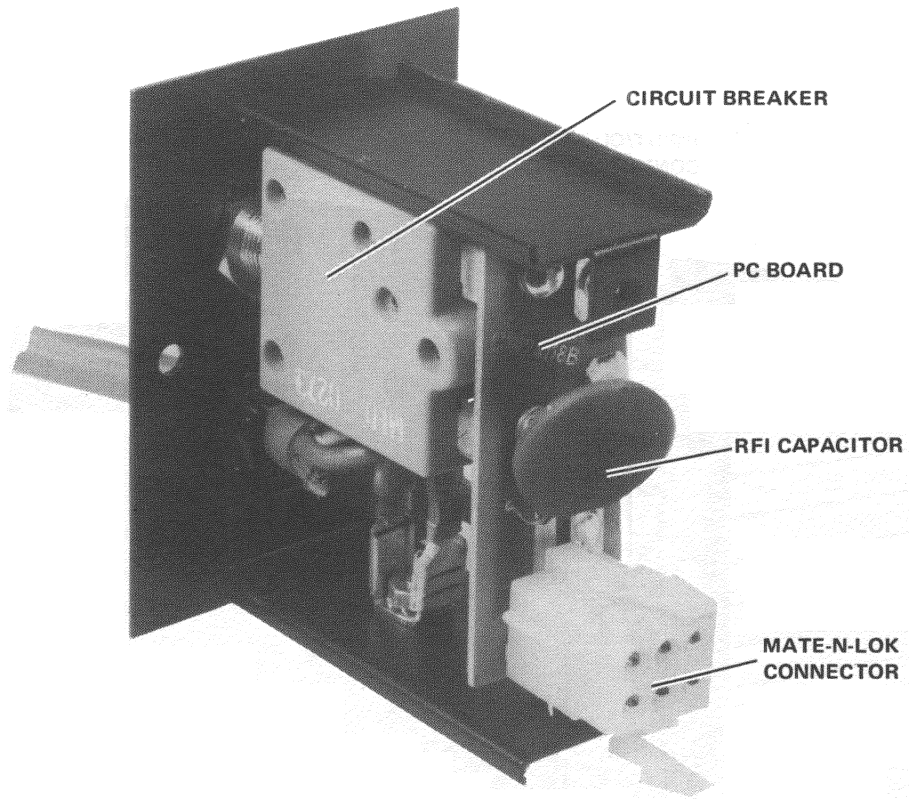

Figure 3-7 BC05T Line Set, Cover Removed

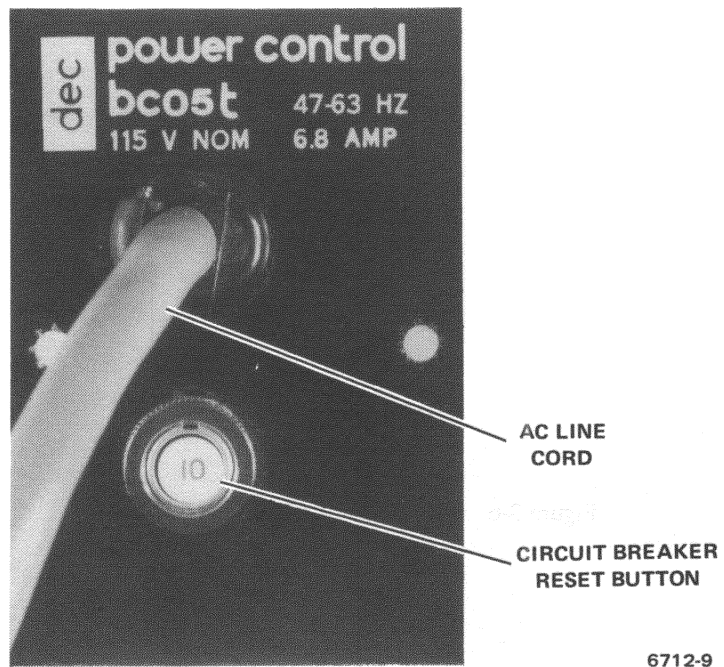

Figure 3-8 BC05T Line Set, Rear View

3.2.3 Wiring Harnesses

Two mechanical features concerning the wiring harnesses are worth mentioning. One is that terminal block TB1 is considered part of the power supply harness (drawing E-IA-7009207-0-0). It is a Cinch #8-540 and contains eight pairs of screw type terminals.

The other feature is that the power distribution board is part of the power to distribution board harness (drawing E-IA-7009208-0-0). It is a printed circuit board and the harness wires are soldered to eyelets on the board. The signals on these wires are connected to five identical 9-pin Mate-N-Lok connectors on the board via the etched circuit.

3.3 SYSTEM FUNCTIONAL DESCRIPTION

A functional block diagram of the power system is shown in Figure 3-9. Assume that the line cord is plugged in and the console switch is OFF. Line voltage is applied to the primary of transformer T3 and produces 28 Vac in the secondary of T3, which is connected to the diode board (PS3). The diode board rectifies the secondary output of T3 to energize the coil of relay K1. The +28 V from PS3 must pass through relay coil K1, PS1 regulator, thermostat, and the console switch to ground to complete the circuit. If the console switch is OFF or the thermostat is open (overtemperature condition), relay K1 cannot be energized. This prevents ac line voltage from being applied to transformers T1 and T2 and all three fans.

When the console switch is placed in the POWER position, the relay coil circuit is completed and the relay is energized. Two sets of normally opened relay contacts now close and ac line voltage is applied to all three fans and the primaries of transformers T1 and T2. The 28 Vac secondary voltage from T1 is applied to the rectifier circuit in the PS1 regulator and the 28 Vac secondary voltage from T2 is applied to the rectifier circuit in the PS2 regulator. The outputs of the regulators are sent to the power distribution board and on to the backplane.

The power supply harness contains two Mate-N-Lok connectors that allow connection to the optional cabinet mounted power control unit. This device allows all units in a single or multi-cabinet system to be turned on using the computer console switch. The power control unit automatically removes ac line power if an overload or overtemperature condition occurs in a cabinet.

A detailed power system interconnection diagram is shown in Figure 3-10. All connector and component pins are identified to allow detailed circuit tracing.

3.4 SYSTEM CIRCUIT DESCRIPTION

3.4.1 Introduction

This paragraph provides circuit descriptions of the 115 V and 230 V line sets, power distribution board, dc regulator, and +5 V regulator.

3.4.2 Line Set

The 115 V and 230 V line sets differ only in the circuit breaker current rating and printed circuit board jumper configuration. For 115 Vac power, the jumpers connect both primaries of transformers T1, T2, and T3 to 115 Vac in parallel (Figure 3-11). For 230 Vac power, the jumpers connect both primaries of each transformer (T1, T2, and T3) to 230 Vac in series (Figure 3-12).

3.4.3 Power Distribution Board

The circuit schematic for the power distribution board is shown in Figure 3-13. The outputs of the dc regulator (PS1) and +5 V regulator (PS2) are sent via the power distribution harness to the board. The harness wires are soldered to eyelets on the board. The signals on these wires are distributed via the etch to the five 9-pin Mate-N-Lok connectors (J1–J5) on the board as shown in Table 3-1.

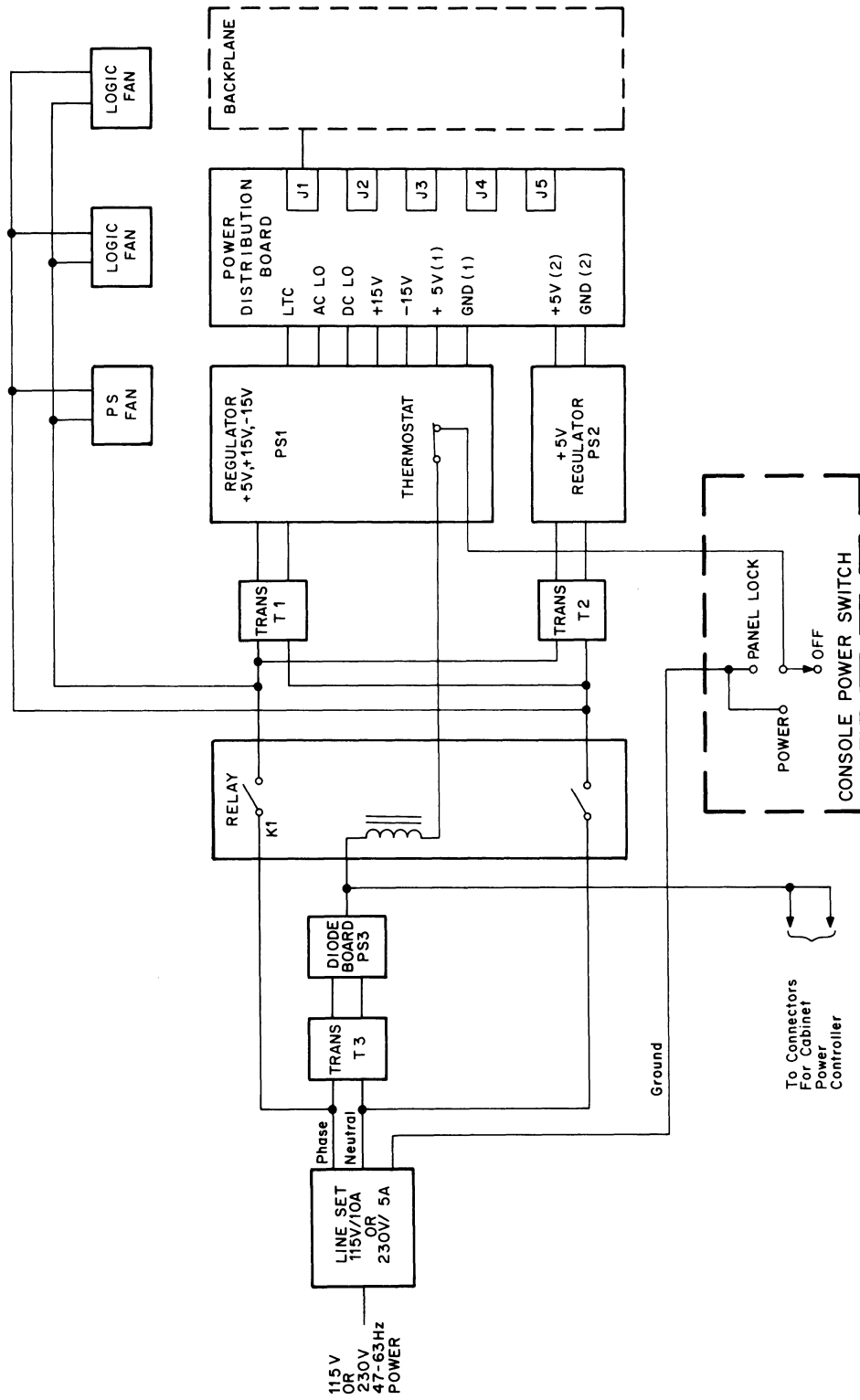

11-1893

Figure 3-9 Power System Functional Block Diagram

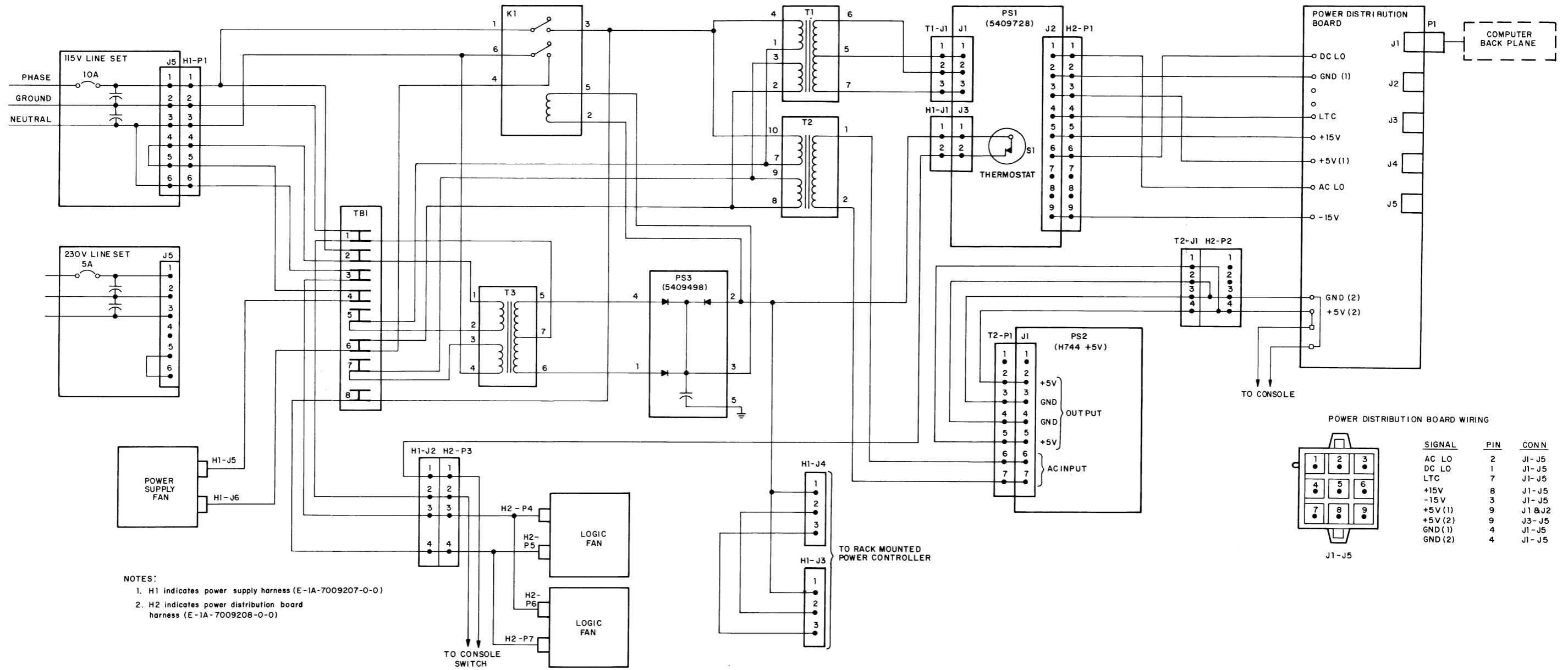

Figure 3-10 Power System Interconnection Diagram

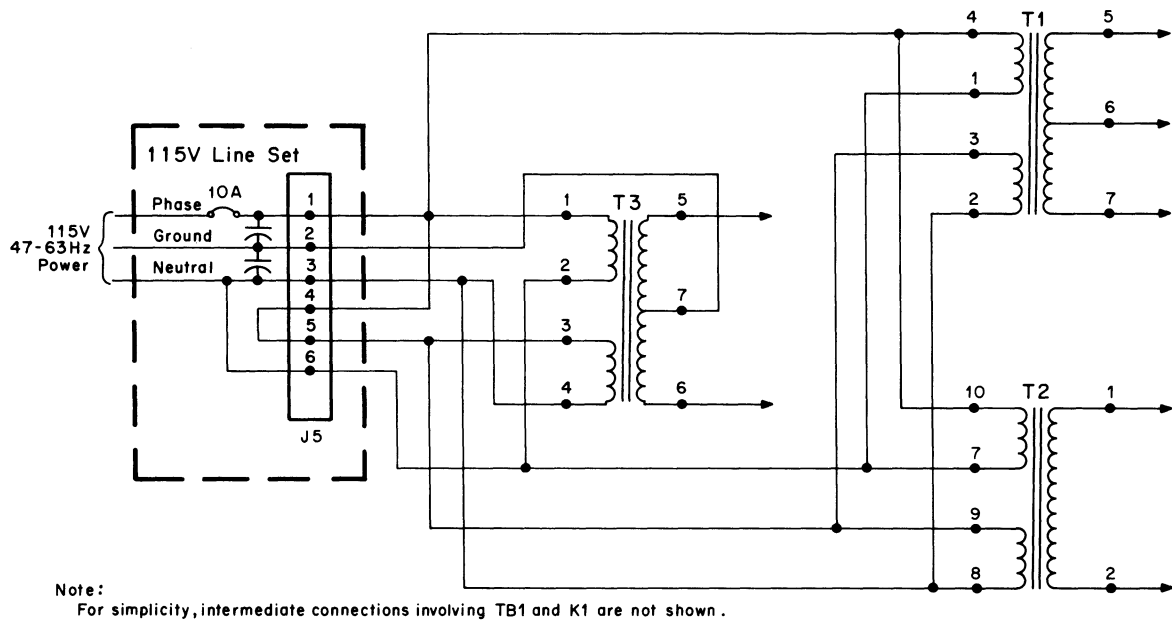

Figure 3-11 Power Application Using 115 V Line Set

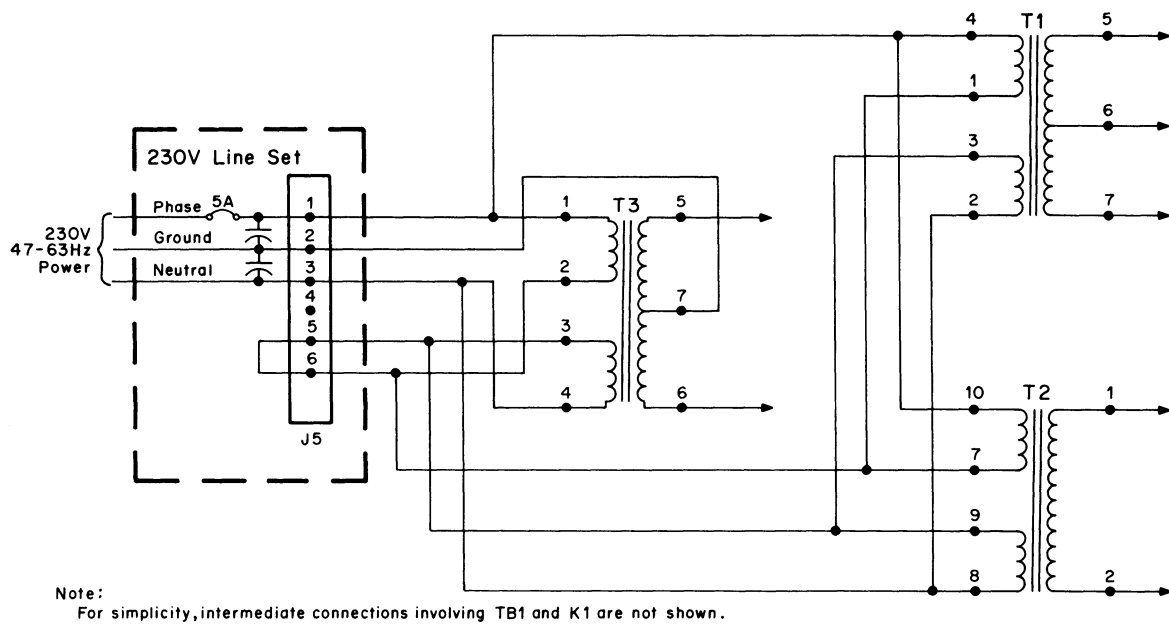

Figure 3-12 Power Application Using 230 V Line Set

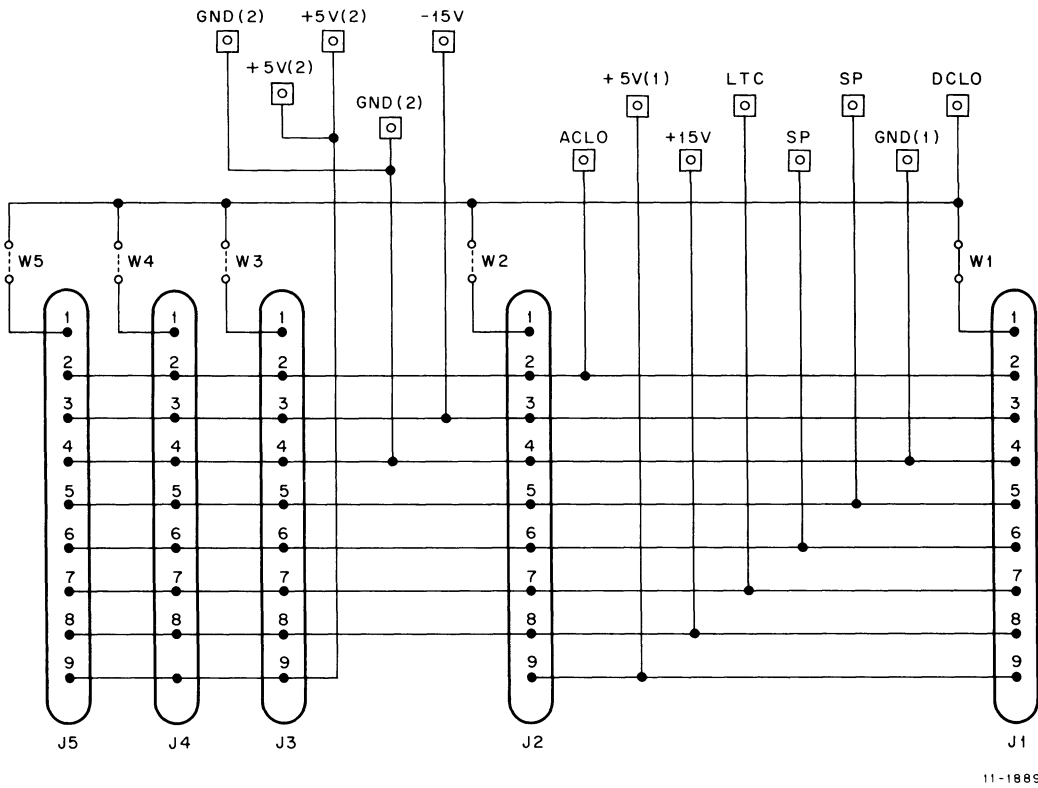

Figure 3-13 Power Distribution Board Circuit Schematic

Table 3-1
Power Distribution Board Signals

Source	Signal	Destination
H744 5 V Regulator	{ +5 V (2) GND (2)	J3, J4, and J5 pin 9
		J1–J5 pin 4**
5409728 dc Regulator	{ DC LO AC LO LTC +5 V (1) +15 V -15 V GND (1)	J1–J5 pin 1*
		J1–J5 pin 2
		J1–J5 pin 7
		J1 and J2 pin 9
		J1–J5 pin 8
		J1–J5 pin 3
		J1–J5 pin 4**

Notes: *Connected to each Mate-N-Lok via a jumper.
**Electrically connected on the board. Pins 5 and 6 on J1–J5 are spares.

CAUTION

Output +5 V (1) is generated by the 5409728 regulator and is available on connectors J1 and J2. Output +5 V (2) is generated by the H744 Regulator and is available on connectors J3–J5. These supplies are separate and should not be connected together.

The current ratings for the power supply outputs are shown below. The ratings listed are maximum; that is, for a particular output, the sum of the loads on the connectors used must not exceed the specified value.

5409728 dc regulator

- +5 V (1) on connectors J1 and J2 is 20 A total
- +15V on connectors J1–J5 is 1 A total
- 15 V on connectors J1–J5 is 8 A total

H744 Regulator

- +5 V (2) on connectors J3, J4, and J5 is 20 A total

Parallel connections of +5 V (2) and GND (2), using Faston tabs on the power distribution board, are provided to connect these outputs to the computer console printed circuit board.

The power distribution board contains a DC LO jumper for each connector (J1–J5). Only one DC LO connection is required per mounting box. In the basic computer, jumper W1 is installed to bring the DC LO signal to the backplane because the processor power harness connects the backplane to the power distribution board at connector J1.

A jumper for each connector is provided because it is possible to mount a backplane in any position and connect it to any power distribution board connector.

The requirement for only one installed DC LO jumper per box is emphasized in the following special case.

Assume that a PDP-11/05 mounting box is to be used as an expander box with a DB11-A Bus Repeater installed along with other options. Unlike previous expansion boxes, the PDP-11/05 box allows the DB11-A to be installed in any position. When connected to the appropriate distribution board connector, the associated DC LO jumper is installed. All other DC LO jumpers must be open to prevent latching up of the DC LO circuit by looping through the power harness if more than one jumper is installed.

Options for the basic computer include a pre-wired backplane and specific power harness to connect the backplane to the power distribution board (Table 3-2).

**Table 3-2
Option Power Harnesses**

Option	Power Harness
MF11-L	70-09206
DD11-B	70-09099
DD11-A	70-09205*

*Not shipped with computer.
Harness must be ordered separately to install customer's DD11-A.

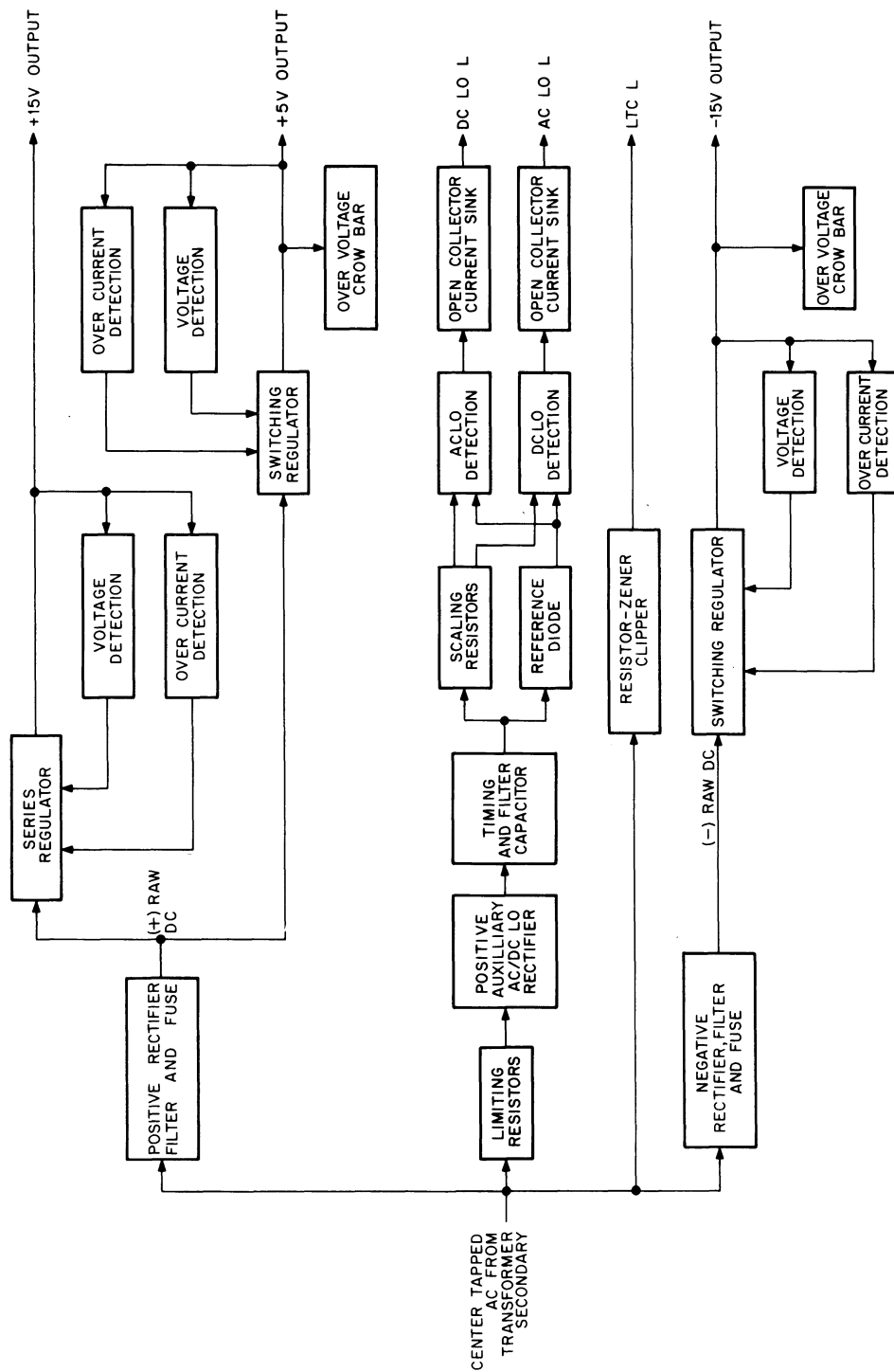

11-1046

Figure 3-14 DC Regulator Block Diagram

The DD11-A and DD11-B are pre-wired backplanes used to mount up to four small peripheral interfaces (equivalent to four quad boards). The DD11-B is a later version of the DD11-A that uses Faston tabs on the wire-wrap pin side to connect with the power harness. The DD11-A uses a power harness that contains a cable connector module which plugs into the connector side of the backplane. The DD11-A is not shipped with the computer; rather, the later DD11-B version is used. If the customer has a DD11-A and wants to install it in the computer, he must order power harness 70-09205.

The KD11-B Processor requires 8.0 A at +5 V and 1 A at -15 V. The power requirements for the MF11-L Memory are listed below.

MF11-L Capacity	Current at +5 V	Current at -15 V
8K	3.4 A	6.0 A
16K	4.9 A	6.5 A
24K	6.4 A	7.0 A

3.4.4 DC Regulator (PS1)

3.4.4.1 Functional Operation – A block diagram of the dc regulator is shown in Figure 3-14. The center tapped output of the power transformer is applied to positive and negative rectifier and filter circuits. The rectifier circuits produce +39 V and -29 V nominal raw dc voltages, which are unregulated but well filtered by the input storage capacitors.

The +39 V is used by an efficient switching regulator circuit to produce the +5 V output. Provisions for overcurrent detection are incorporated in the regulator circuit so that excess current is limited when there is a malfunction in the load. The +5 V output is also protected against overvoltage by a crowbar circuit which limits the output to an absolute maximum of 7 V; at approximately 6 V, the crowbar circuit blows fuse F1 in the output circuit of the rectifier.

The +15 V output is produced by a series regulator circuit. It has no overvoltage protection circuit. Fuse F1 is used for protection in case of a malfunction in the +15 V regulator.

The -39 V is used by the -15 V circuit, which is similar in operation to the +5 V regulator circuit. The -15 V crowbar circuit limits the output to an absolute maximum of -22 V. At approximately -19 V, the crowbar circuit blows fuse F2 in the output circuit of the rectifier.

The real-time clock synchronizing signal (LTC L) is generated by a simple Zener clipper that is fed from the transformer secondary.

The BUS AC LO L and BUS DC LO L signals are used to warn the Unibus of imminent power failure. Circuits detect the transformer secondary voltage and generate two timed TTL-compatible open-collector signals that are used for power fail functions by devices on the Unibus.

3.4.4.2 Generation of Raw DC Voltages – As stated in the previous paragraph, the centertapped transformer secondary voltage is rectified and filtered prior to being fed to the three dc regulators.

The circuitry is shown in Figure 3-15. Bridge rectifier D14 is mounted on the heat sink and input capacitors C1 and C2 are mounted on the bottom of the regulator module. These capacitors filter the input dc and are large enough to provide power storage for at least 25 ms when the input power is shut off or fails.

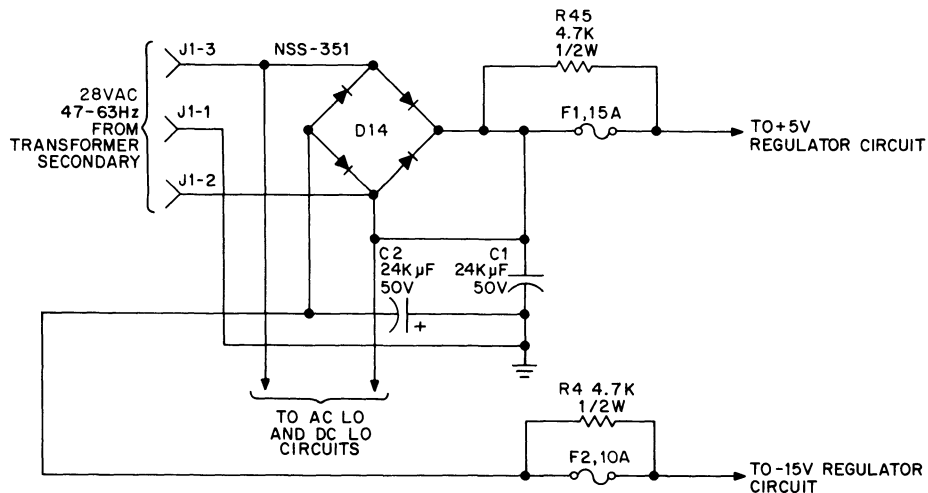

11-1177

Figure 3-15 Rectifier and LTC Circuits

Two fuses are used to protect the regulator and load during faults. A 15 A fuse protects both the +5 V and +15 V outputs and a 5 A fuse protects the -15 V output. Normally, the fuses do not blow when a regulator output is shorted because the three outputs are electrically overcurrent protected. However, the appropriate fuse does blow in case of +5 V or -15 V overvoltage crowbar or in case of failure in one of the overcurrent circuits.

The resistor across each fuse provides a slow (100 – 150 seconds) discharge of C1 or C2 when the power is turned off after a fuse has blown. The capacitors are placed ahead of the fuse to limit the energy in any fault and thus better protect the outputs.

3.4.4.3 LTC L Circuit – The LTC L real-time clock synchronizing signal (Figure 3-15) is generated by a Zener clipper circuit. The output waveform is a clipped sine wave at line frequency. For the positive half of the output sine wave, D13 clips at about +3.9 V and for the negative half D13 clips at its forward voltage of -0.7 V.

3.4.4.4 BUS AC LO L and BUS DC LO L Circuits – The circuitry shown in Figure 3-16 is used to generate the timed Unibus power status signals that are used for power fail function.

The transformer secondary voltage is rectified by D1 and D2 and filtered by C9 and R1, R14. Circuit parameters are chosen so that the voltage across C9 rises slower than the three regulated output voltages on powerup and decays faster than the three regulated output voltages on powerdown.

Two differential amplifier circuits are used to detect power status: Q17, Q18 generates BUS DC LO L; and Q15, Q16 generates BUS AC LO L. Both differential amplifiers share a common reference Zener diode D3, which is fed approximately 1 mA by R3.

As C9 charges subsequent to powerup, first Q17, Q18, and then Q15, Q16 change state; the reverse is true during powerdown. When C9 starts to charge, Q17 and Q16 are on and Q15 and Q18 are not conducting. As C9 charges further, Q18 starts to conduct into R7 and raises the voltage on the cathode of D3. This acts as positive feedback and snaps Q17 off and Q18 on more solidly. A few milliseconds later, the voltage across C9 has risen sufficiently for the same process to take place in differential amplifier Q15, Q16. The status of each differential amplifier is followed by the germanium transistor open-collector output stages Q19, Q20 for BUS DC LO L, and Q13, Q14 for BUS AC LO L. These stages clamp the Unibus at about +0.4 V until the differential amplifier circuits sequentially signal them across R11 and R12 that power is up. The outputs then rise to about +5 V as dictated by the Unibus loading and pull-up termination resistors.

The sequence is as follows:

powerup → then BUS DC LO L = 0 → then BUS AC LO L = 0
 0 = high (+3 V)

powerdown → then BUS AC LO L = 1 → then BUS DC LO L = 1
 1 = low (+0.4 V)

During a power-down sequence, after BUS AC LO L goes low, there is sufficient storage in capacitors C1 and C2 to maintain output voltage long enough to permit the power fail circuit to operate. The open collector stages are designed to clamp the Unibus to 0.4 V maximum, even when there is no ac input to the regulator. They are inherently biased on by R11 and R12 until the differential amplifiers signal that power is OK.

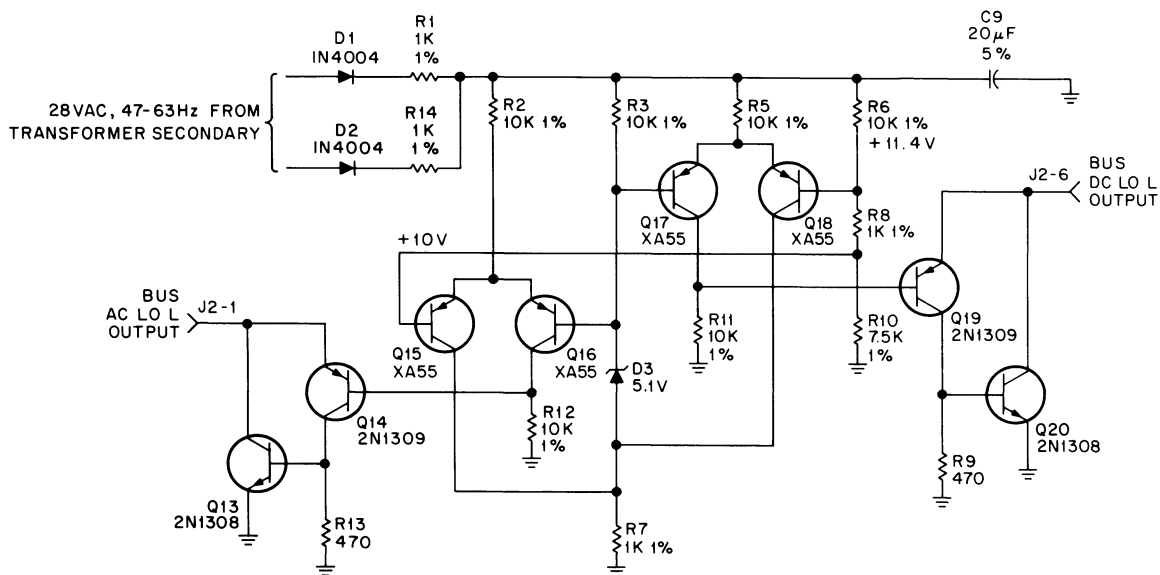

11-1176

Figure 3-16 BUS AC LO and BUS DC LO Circuits

3.4.4.5 +15 V Regulator Circuit – The +15 V regulator shown in Figure 3-17 is a simple series regulator. The pass transistor Q1 is a high-gain power Darlington type and is mounted on the heat sink. Base drive current is supplied to Q1 via R38. Q3 limits the value of this current to the required value by shunting it away from the Q1 base. Voltage detector amplifier Q4 biases on Q3 and thus limits current in Q1. The +15 V output voltage is sampled on the viewing chain R34, R35, R36 and compared to the voltage across reference Zener D8, which is fed by R37. If the output tries to increase from the regulated value, the emitter of Q4 is made more negative (relatively) than its base and conduction through Q4 increases. This increases the conduction through Q3 and causes Q1 to shut down sufficiently to restore the output voltage to the regulated value. Ambient temperature compensation of the voltage detector is essentially flat since D8 has a +2 mV/°C temperature coefficient and the base emitter junction of Q4 has a -2 mV/°C temperature coefficient.

R35 is the +15 V voltage adjustment potentiometer and C18 is a high frequency stabilization capacitor. Q2 is the overload detector; when the output current reaches 1.5 A nominal, the voltage across R33 is sufficient to cause Q2 to conduct which removes base drive from Q1 and causes the regulator to current limit.

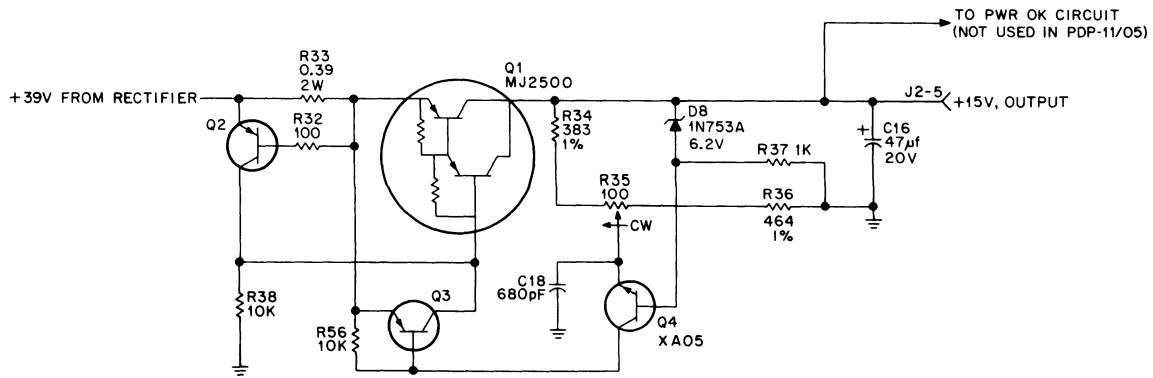

11-0968

Figure 3-17 +15 V Regulator Circuit

3.4.4.6 +5 V Regulator Circuit – The +5 V regulator is similar to the +15 V regulator in that the sampled output voltage is compared to the voltage across a reference Zener by a voltage detector transistor, which, in turn, controls the drivers for the main pass transistor. An overcurrent circuit is used also. The +5 V regulator circuit is shown in Figure 3-18.

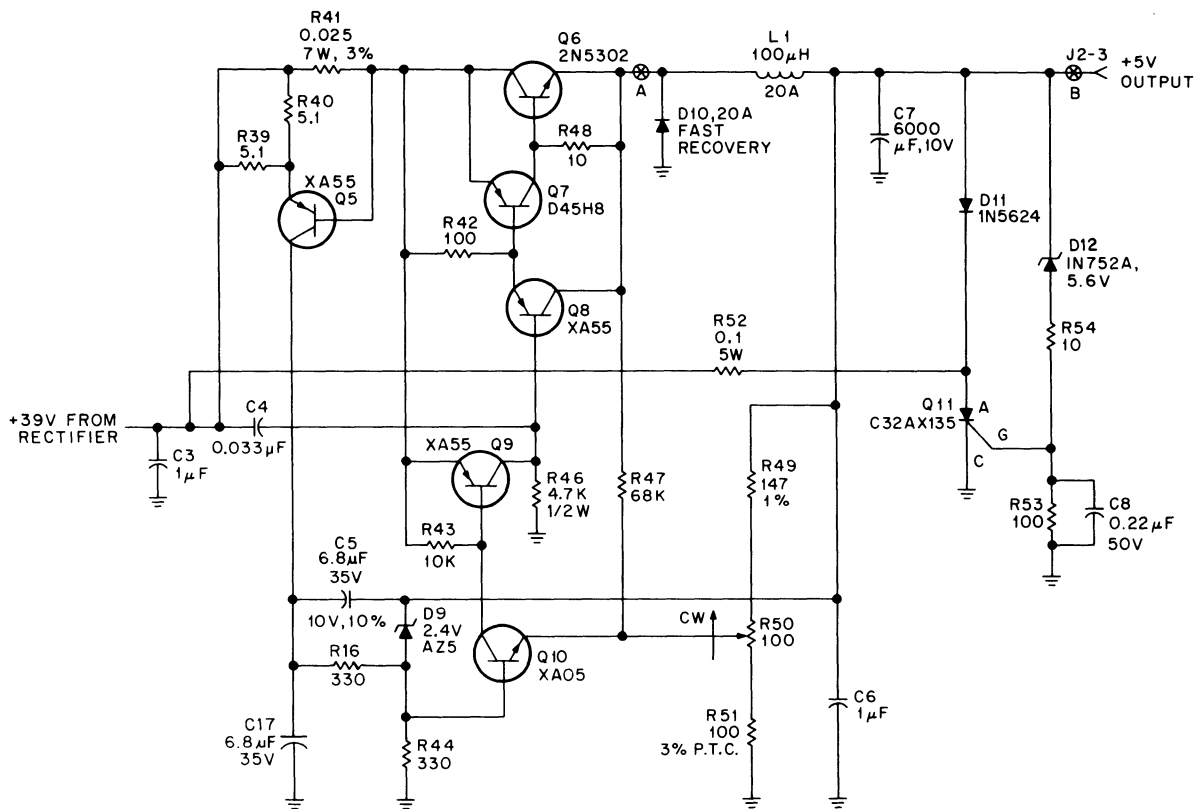

11 1175

Figure 3-18 +5 V Regulator Circuit

The viewing chain consists of R49, R50, and R51. The reference Zener is D9, which is fed by R44. Q10 is the detector amplifier. The pass transistor Q6 and first stage driver Q7 are mounted on the heat sink. The predriver Q8 is turned on by R46. The current is diverted from the base of Q8 by off-driver Q9, which is controlled by Q10. The +15 V and the +5 V regulators are similar in operation; i.e., a tendency for the output voltage to rise results in more conduction through Q10 and resultant limiting of conduction through Q6.

Here the similarity ends. The +5 V regulator operates in the switching mode for increased efficiency. To get the regulator to switch, positive feedback is applied to the voltage detector input via R47. Thus, the whole regulator acts as a power Schmitt trigger and is either completely turned on or turned off, depending on whether the output voltage is too high or too low. When Q6 is on, it supplies current through filter choke L1 to the output smoothing capacitor C7 and the load. When Q6 is off, the L1 current decays through commutating diode D10, which becomes forward biased by the back emf of L1. The waveform across D10 is a 30 V nominal rectangular pulse train. The filtered output across C7 is thus +5 Vdc with about a 200 mV peak-to-peak 10 kHz nominal sawtooth of superimposed ripple. At the crest of the ripple, Q6 turns off and at the valley Q6 turns on. This switching mode of operation limits the dissipation in the circuit to the saturated forward losses of Q6 and D10 and the switching losses of Q6. The resultant high efficiency allows the use of a small heat sink and relatively few power transistors.

R50 is the voltage adjustment potentiometer. R51 is a positive temperature coefficient wire-wound resistor that compensates for the fact that the Q10 base-emitter junction and the reference diode D9 both have negative voltage temperature coefficients. Q5 current, limited by R39 and R40, detects the overcurrent signal generated across resistor R41, which is in series with the Q6 collector.

Output fault current is limited to a safe value because conduction of Q5 makes the reference voltage across D9 decrease to zero. This causes Q10 to conduct and shuts down the regulator. C5 is an averaging capacitor, which is necessary in the circuit because the current through R41 is pulsating.

High frequency bypass capacitors are used on the input and output of the regulator (C3 and C6, respectively) and C4 is used to slow down the turn-on of Q6 to allow D10 to recover from the on state without a large reverse current spike.

If a malfunction causes the output voltage to increase beyond about 6 V, Zener diode D2 conducts and fires silicon-controlled rectifier Q11. This crowbars the output voltage to a low value through D11 and blows fuse F1 in the rectifier circuit through R52.

3.4.4.7 -15 V Regulator Circuit – The -15 V regulator circuit is shown in Figure 3-19. It is essentially the complement of the +5 V regulator circuit and differs only in the following minor details.

- a. The crowbar device is a Triac (Q27) instead of an SCR. No temperature compensating resistor is required because Q26 and D4 track each other, as in the +15 V regulator.
- b. The detailed interconnection of the drivers and the circuit values are different.
- c. The -15 V output voltage is adjusted by potentiometer R26.

3.4.5 +5 V Regulator (PS2)

3.4.5.1 Functional Operation – A functional block diagram of the +5 V regulator is shown in Figure 3-20. The 28 Vac from the secondary of transformer T2 is full wave rectified and filtered. This raw dc voltage (approximately 39 V) is used by a switching regulator circuit to produce the +5 V output. An overcurrent detection circuit is incorporated in the regulator circuit to limit excess current when there is a fault in the load. The +5 V output is also protected against overvoltage by a crowbar circuit that limits the voltage to +7 V. Before the output reaches +7 V, the crowbar circuit blows the fuse in the rectifier output. A circuit schematic of the +5 V regulator is shown in Figure 3-21 and is referenced in the subsequent paragraphs.

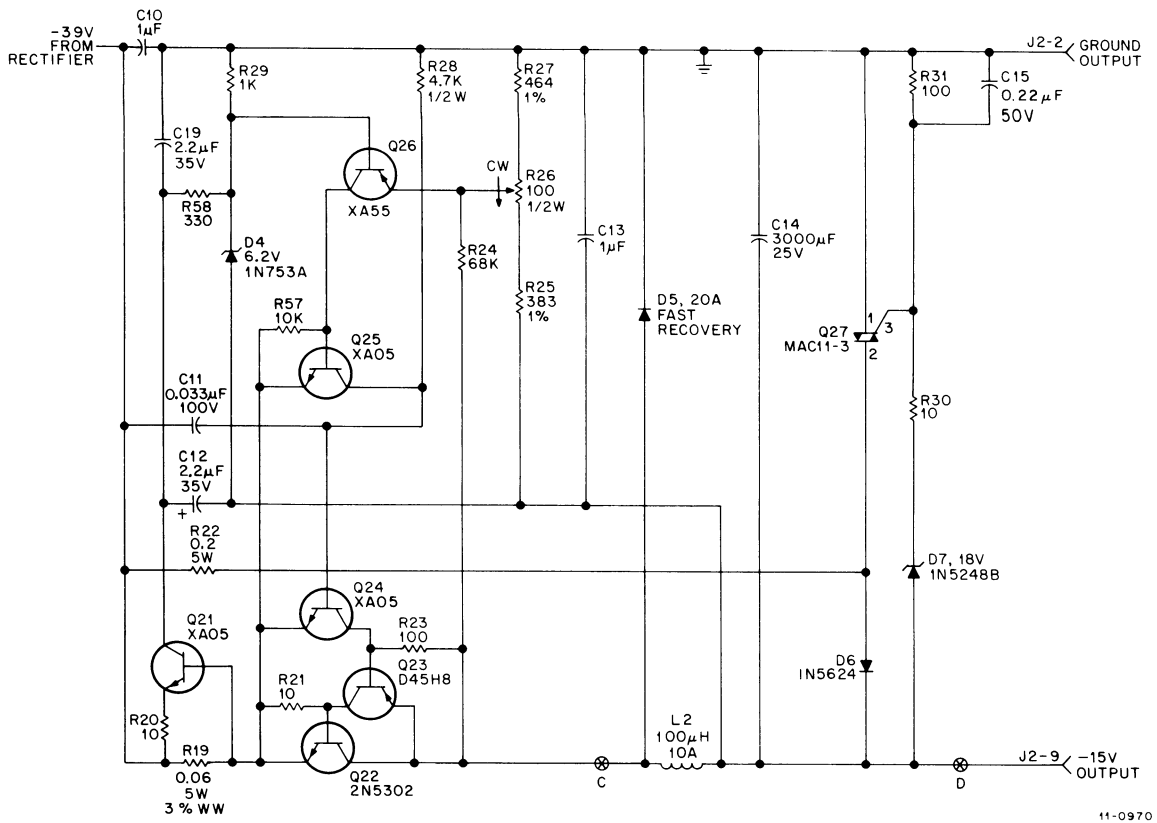

Figure 3-19 -15 V Regulator Circuit

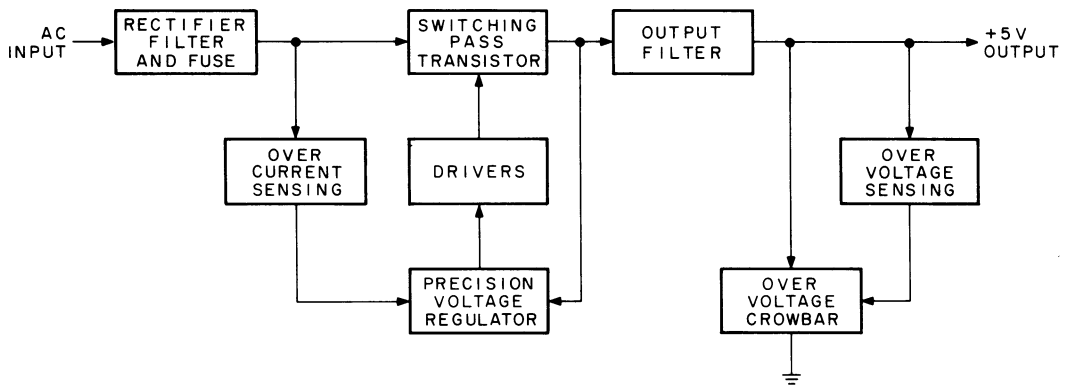
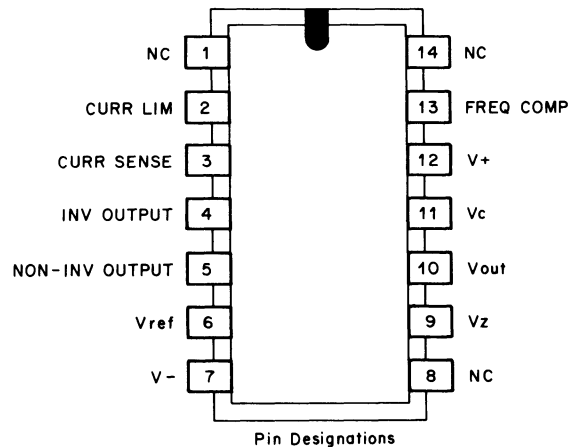
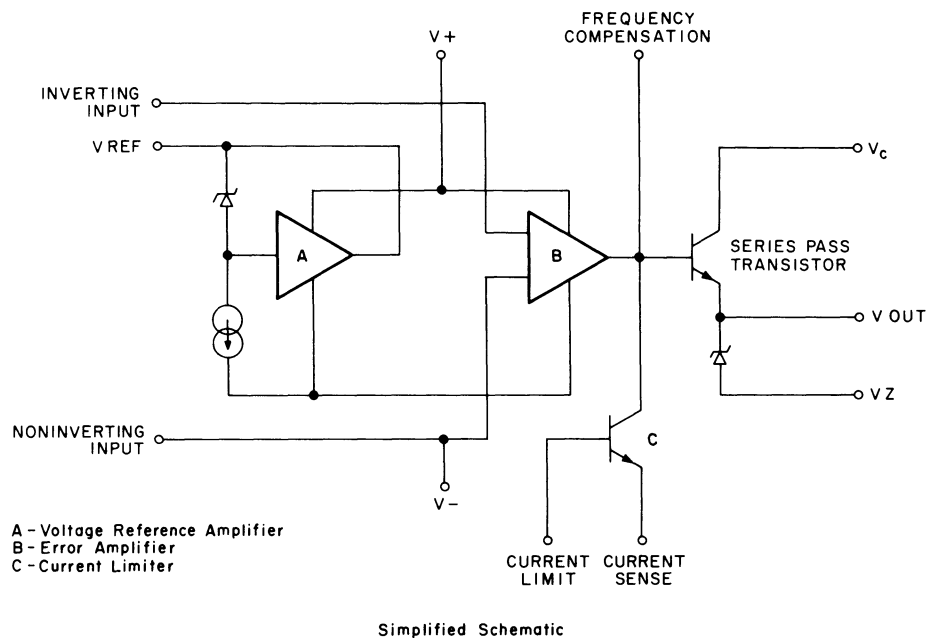

Figure 3-20 +5 V Regulator (PS2) Functional Block Diagram

3.4.5.2 Generation of Raw DC Voltage – The 28 Vac from transformer T2 is applied to full wave rectifier D1 via pins 6 and 7 of connector J1. The rectifier output is approximately +39 V and is filtered by capacitor C1. Resistor R1 is a bleeder resistor and dissipates the charge on C1 during shutdown. The 15 A fuse (F1) protects the regulator and load during faults. Normally, the fuse does not blow when the regulator output is shorted because the output is protected against overcurrent operation. The fuse does blow if the crowbar circuit fires or in case of failure in the overcurrent protection circuit.

3.4.5.3 Regulator Circuit – The regulated +5 V is sampled by resistors R19 and R7. The magnitude of this voltage is compared to a precision 5 V reference voltage produced by voltage regulator E1 and voltage divider R17, R14, and R18. This regulator responds to ± 0.05 V differences between the sensed output and the reference.

E1 is an integrated circuit in a 14-pin dual in-line package. A simplified equivalent circuit and package configuration are shown in Figure 3-22.



11-1895

Figure 3-22 Voltage Regulator (E1) Equivalent Circuit and Package Configuration

The +5 V output passes through transistor Q2 to the output filter (C8, C9, and L1) and to the load. Q2 is called the pass transistor and is mounted on the heat sink. Transistor Q2 is operated in the switched mode; therefore, it is either on or off. It is controlled by drivers Q5, Q4, and Q3 that are controlled by voltage regulator E1. A simplified +5 V regulator circuit and associated waveforms are shown in Figure 3-23 to illustrate the operation of a switching regulator.

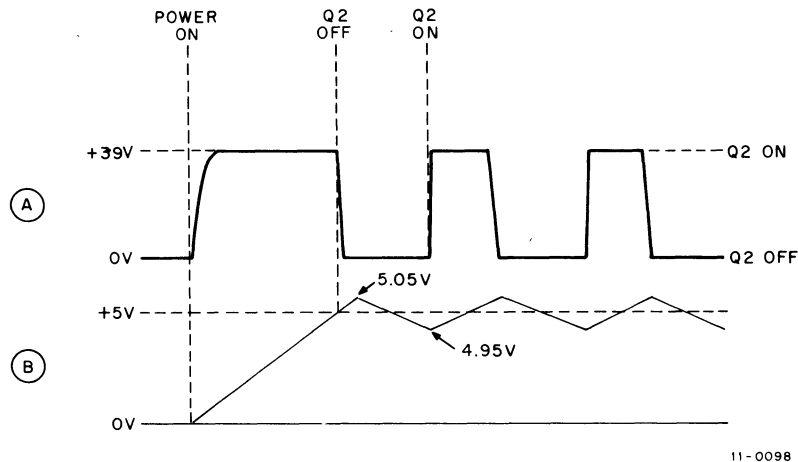

11-0098

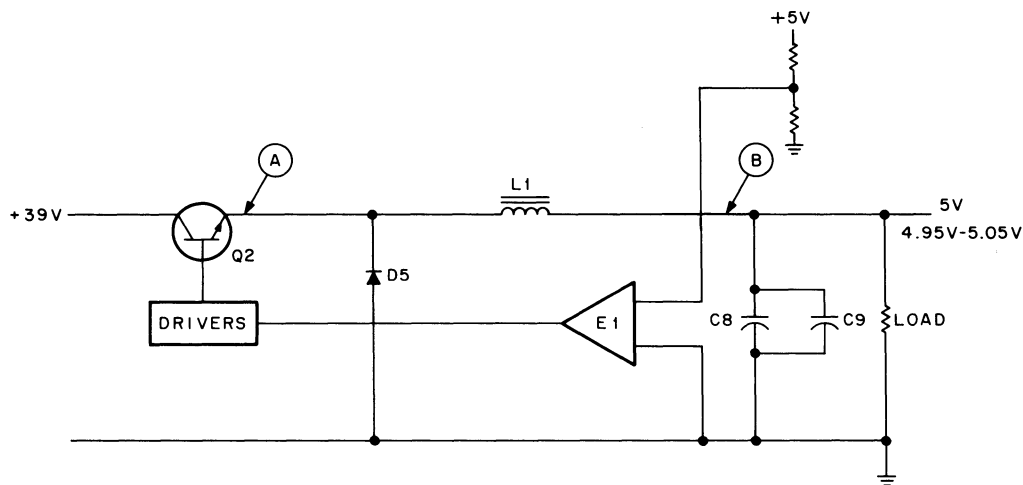

11-0097

Figure 3-23 Simplified 5 V Switching Regulator Schematic and Waveforms

When power is applied, the drivers turn on Q2 and the output voltage starts to rise toward +39 V. Because of inductor L1 in the circuit, the voltage rise is relatively slow. When the output voltage reaches 5.05 V, E1 signals the drivers to cut off Q2. As the field associated with L1 starts to collapse, L1 current flows through the load to ground and returns to the other side of L1 through commutating diode D5, which is forward biased by the L1 back emf. The output voltage decays, and when it reaches 4.95 V, E1 signals the drivers to turn on Q2 and current is supplied through L1 to C8 and C9 and the load. The output voltage rises and when it reaches 5.05 V, E1 again signals the

drivers to cut off Q2. The circuit oscillates in this manner and generates a 39 V p-p rectangular pulse train across diode D5. The regulator circuit acts like a power Schmitt trigger and is either on or off depending on whether the output voltage is too low or too high. The filtered output across C8 and C9 is thus +5 V with about a 100 mV p-p 10 kHz nominal sawtooth of superimposed ripple. The output filter is an averaging device so the rectangular pulse train appears as an average voltage (+5 V nominal) at the output terminal.

If the load increases, the output voltage decays faster and Q2 turns on sooner so that the waveform frequency (duty cycle) increases. Conversely, if the load decreases, the waveform frequency (duty cycle) decreases.

The driving chain for Q2 consists of first stage driver Q3, predriver Q4, and off driver Q5, which is controlled by E1. Off driver Q5 diverts current from the base of Q4 and thus controls it. Q5, R2, and Zener diode D2 are used to generate +15 V for the operation of E1 from the +39 V raw input.

3.4.5.4 Overcurrent Protection Circuit – The regulator is protected from damage by high current due to a fault (short circuit) in the load. The current is limited to about 30 A by the overcurrent protection circuit that consists of Q1, R3 through R6, R25, R27, Q7, and C4.

The current drawn by the load through pass transistor Q2 is sensed by monitoring the voltage drop across 0.02 Ω resistor R4 that is in series with the +39 V raw voltage. If the current exceeds 30 A, the drop across R4 increases and forward biases Q1 and it turns on. Capacitor C4 charges and overcomes the bias on Q7 which turns it on. This action turns on E1 which, in turn, cuts off pass transistor Q2. The forward bias on Q1 is reduced and it turns off. Capacitor C4 discharges and holds E1 off for a period of time during which the current drops nearly to zero. When C4 discharges, E1 turns on to re-establish the output voltage. If the fault still exists, the overcurrent circuit turns off Q2 again. As long as the fault exists, the regulator oscillates in this mode and limits output current to approximately 30 A.

3.4.5.5 Overvoltage Crowbar Circuit – The +5 V is used to power digital logic devices that must be protected against voltage in excess of 7.0 V. This protection is provided by the overvoltage crowbar circuit that consists of silicon controlled rectifier D7, Zener diode D3, diode D8, Q6, R22, R23, and C7.

During normal operation, the trigger input to SCR D7 is at ground potential because the voltage across Zener diode is less than the 5.1 V required to cause it to conduct. If a malfunction occurs that increases the output voltage above 6.0 V, Zener D3 turns on which forward biases Q6. When Q6 conducts, resistor R23 in the SCR gate circuit draws current and turns on D7. The +5 V output is short circuited to ground. Capacitor C7 bypasses R23 to ground so that line transients of short duration that might cause D3 and D4 to conduct do not fire the crowbar.

3.5 POWER SUPPLY MAINTENANCE

3.5.1 Introduction

Power supply maintenance information includes the following items:

- a. Checking and adjusting voltages
- b. Removing power supply
- c. Troubleshooting procedures

3.5.2 Checking and Adjusting Voltages

The power supply has four adjustable output voltages. Three voltages [+5 V (1), +15 V, and -15 V] are associated with the 5409728 DC Regulator and one [+5 V (2)] is associated with the H744 +5 V Regulator.

The computer must be extended more than half way out of the cabinet to provide access to all four adjustments. The three dc regulator adjustments are located in a vertical line midway on the right side of the computer; from top to bottom they are +15 V, +5 V and -15 V. The H744 Regulator adjustment is located on the bottom of the computer approximately 15 in. from the front and 1-1/2 in. from the right side. In each case, access is provided through holes in the computer mounting box and power supply chassis (Figure 3-24).

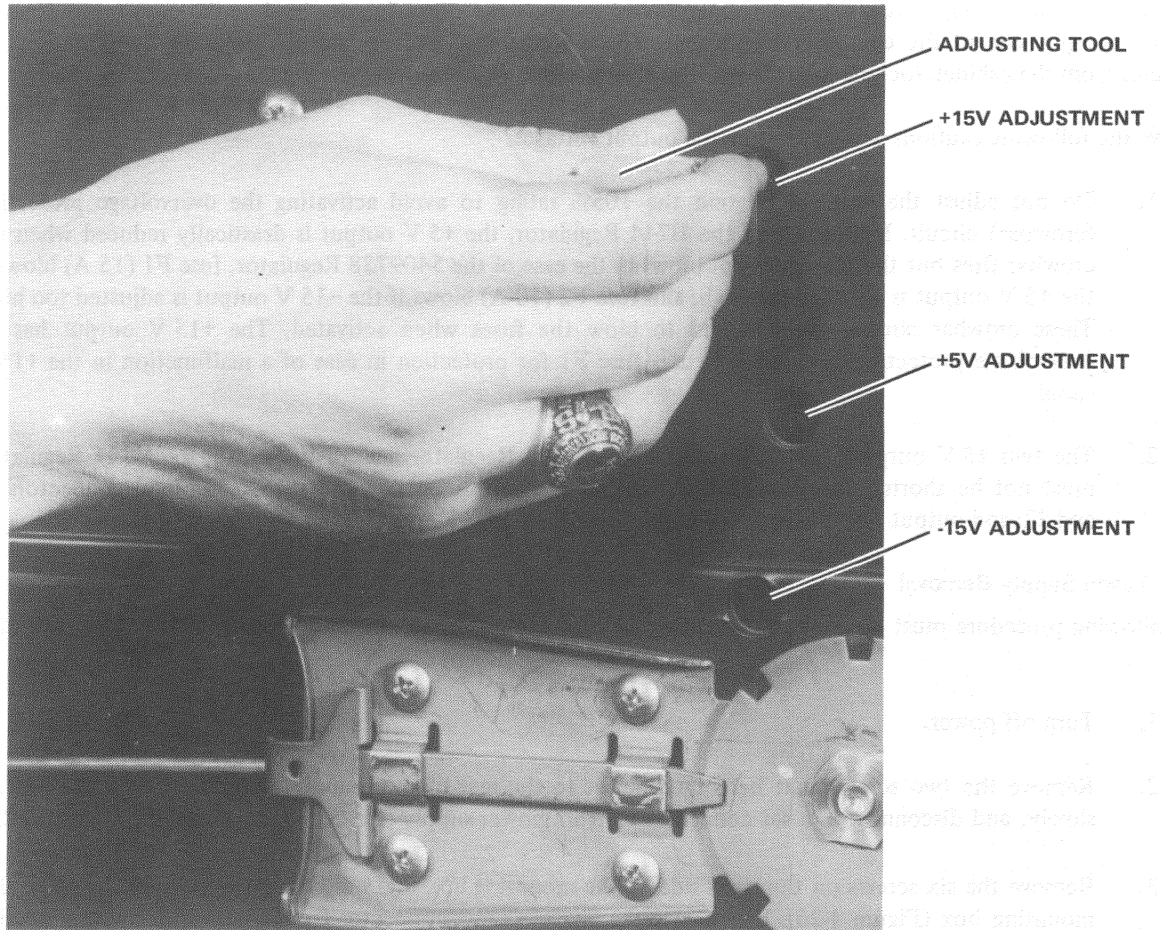

6712-2

Figure 3-24 Power Supply Adjustments

All adjustments are controlled by potentiometers with slotted-head shafts that are conveniently rotated using a small blade type screw-driver. Clockwise rotation increases the voltage in each case. The output voltages should be checked and adjusted as close to nominal as possible. The nominal values and allowable tolerances are shown below.

5409728 Regulator Output Voltages

Nominal Value and Tolerance	Equivalent Range
5.0 V \pm 5%	4.75 V to 5.25 V
15.0 V \pm 5%	14.25 V to 15.75 V
-15.0 V \pm 5%	-14.25 V to -15.75 V

H744 Regulator Output Voltage

Nominal Value and Tolerance	Equivalent Range
5.0 V \pm 5%	4.75 V to 5.25 V

When adjusting the voltages, use a digital voltmeter and measure the output under load at the connectors (Faston tabs) on the pin side of the computer backplanes. These connectors are reached conveniently by extending the computer from the cabinet, locking it in the 90° front up position and removing the bottom cover.

Observe the following cautions when adjusting the output voltages.

1. Do not adjust the voltages beyond the 105% rating to avoid activating the overvoltage protection (crowbar) circuit. In the case of the H744 Regulator, the +5 V output is drastically reduced when the crowbar fires but the fuse does not blow. In the case of the 5409728 Regulator, fuse F1 (15 A) blows if the +5 V output is adjusted too high; and fuse F2 (10 A) blows if the -15 V output is adjusted too high. These crowbar circuits are designed to blow the fuses when activated. The +15 V output has no overvoltage protection circuit but it uses fuse F1 for protection in case of a malfunction in the +15 V supply.
2. The two +5 V outputs, +5 V(1) from the 5409728 Regulator and +5 V(2) from the H744 Regulator, must not be shorted together. Output +5 V(1) is available on power distribution board connectors J1 and J2; and output +5 V(2) is available on connectors J3, J4, and J5 of this board.

3.5.3 Power Supply Removal

The following procedure must be used to prevent damage to the power supply during removal from the mounting box:

1. Turn off power.
2. Remove the two screws that hold the line set to the rear of the mounting box, withdraw the line set slowly, and disconnect line set connector J5 from power supply harness connector H1-P1 (Figure 3-25).
3. Remove the six screws on the right side of the mounting box that hold the power supply chassis to the mounting box (Figure 3-26). Disconnect the console cable connector from the Berg connector on the M7260 module and move the cable away from the power supply cover. Remove the four screws that secure the cover and remove it from the power supply.
4. Disconnect the following connectors that are accessible at the rear of the power supply (Figure 3-27).
 - a. Power Supply harness connector H1-J2 from power distribution harness connector H2-P3.
 - b. Power distribution harness connector H2-P2 from transformer connector T2-J1 (2 red and 2 black wires).

CAUTION

The dc regulator output connector PS1-J2 is still connected but it is not accessible.

5. Lift the power supply chassis slowly upward until it is free of the compartment in the mounting box (Figure 3-28). Rest the bottom of the power supply chassis on the top of the mounting box and remove power distribution harness connector H2-P1 from dc regulator output connector PS1-J2 (Figure 3-29).
6. Place the power supply on a bench. Be careful when lifting and carrying the power supply because its center of gravity is near the front end.

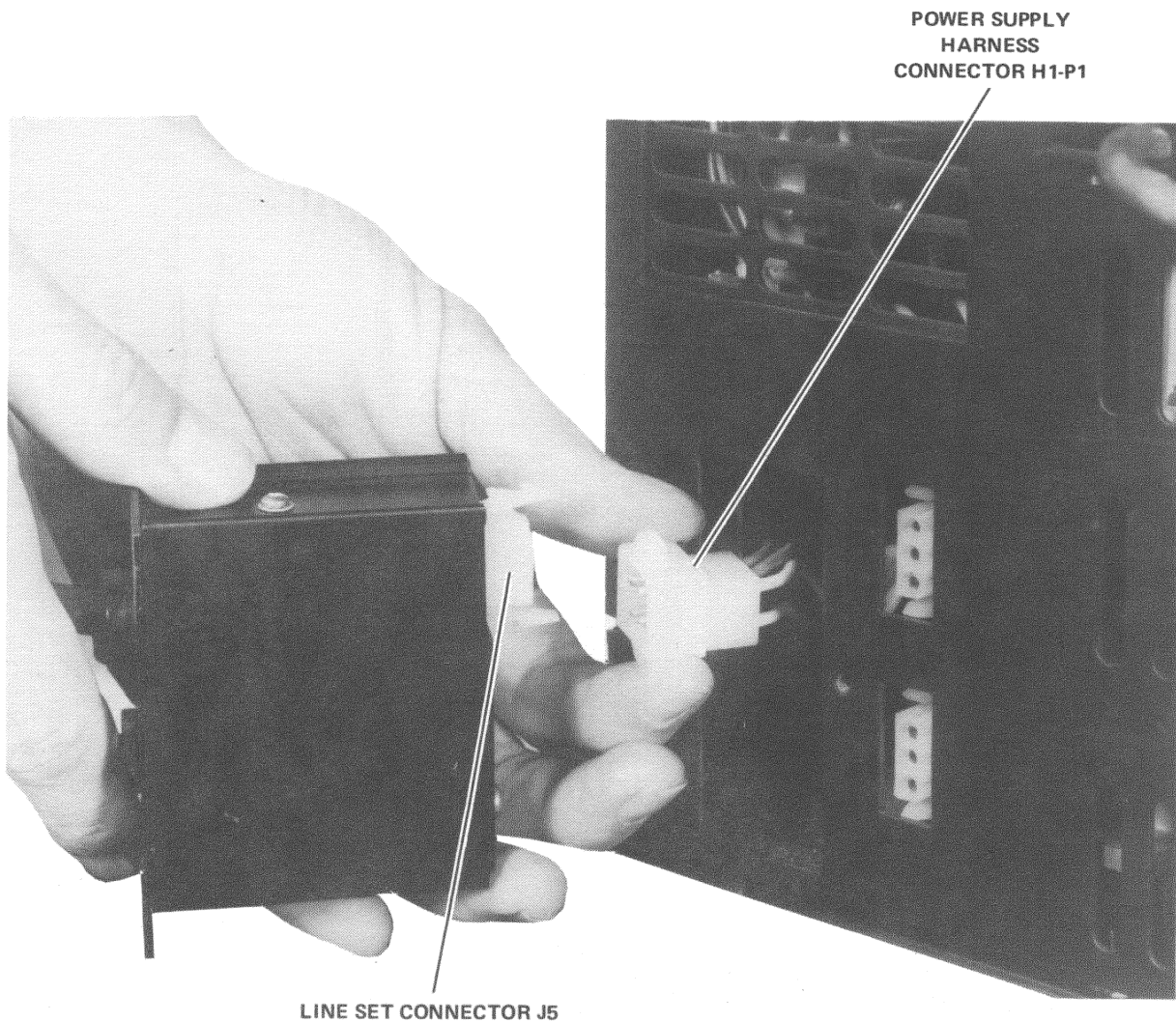

6712-1

Figure 3-25 Disconnecting Line Set From Power Supply

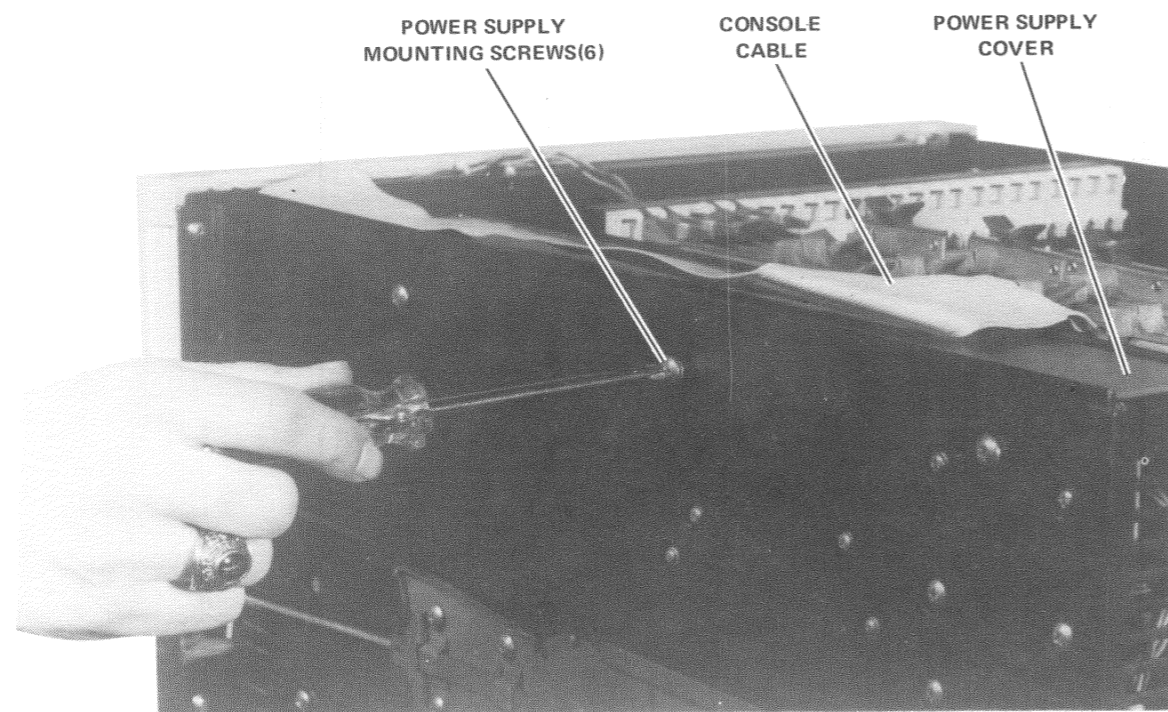

6712-5

Figure 3-26 Removing Power Supply Mounting Screws

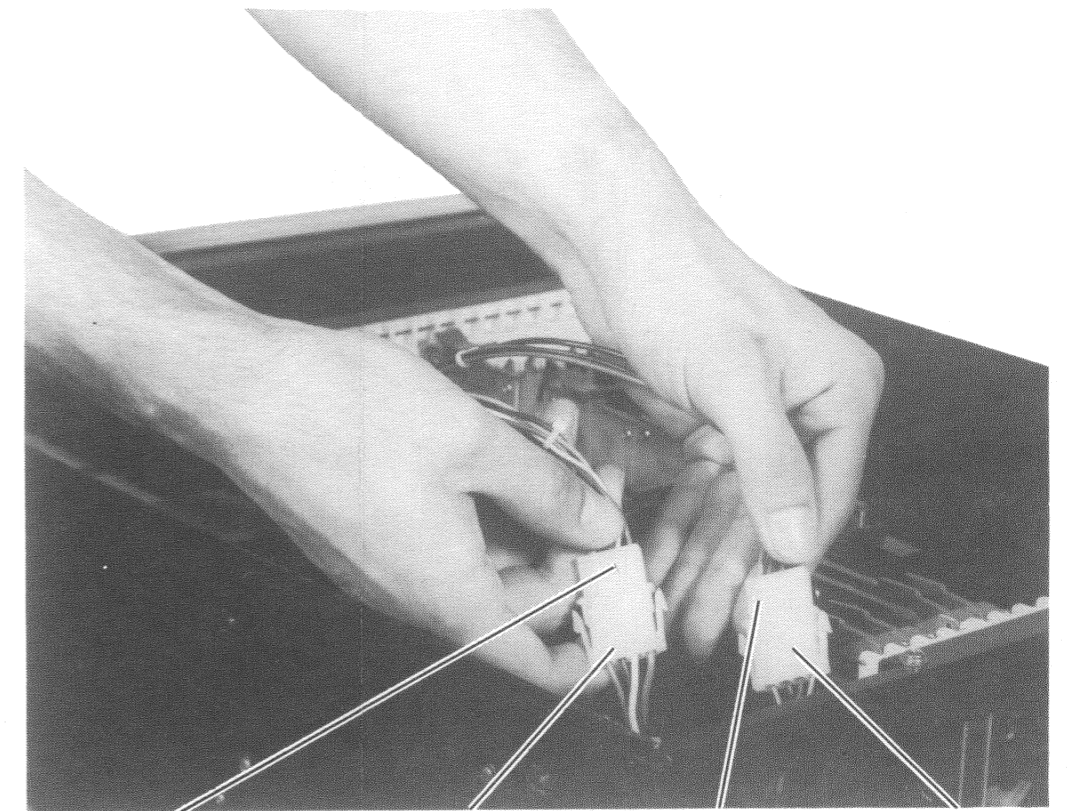

POWER DISTRIBUTION
HARNESS
CONNECTOR H2-P3

POWER SUPPLY HARNESS
CONNECTOR H1-J2

POWER DISTRIBUTION
HARNESS
CONNECTOR H2-P2

TRANSFORMER
CONNECTOR T2-J1
(2 RED AND 2 BLACK
WIRES)

6712-6

Figure 3-27 Removing Power Distribution Harness Connectors H2-P2 and H2-P3

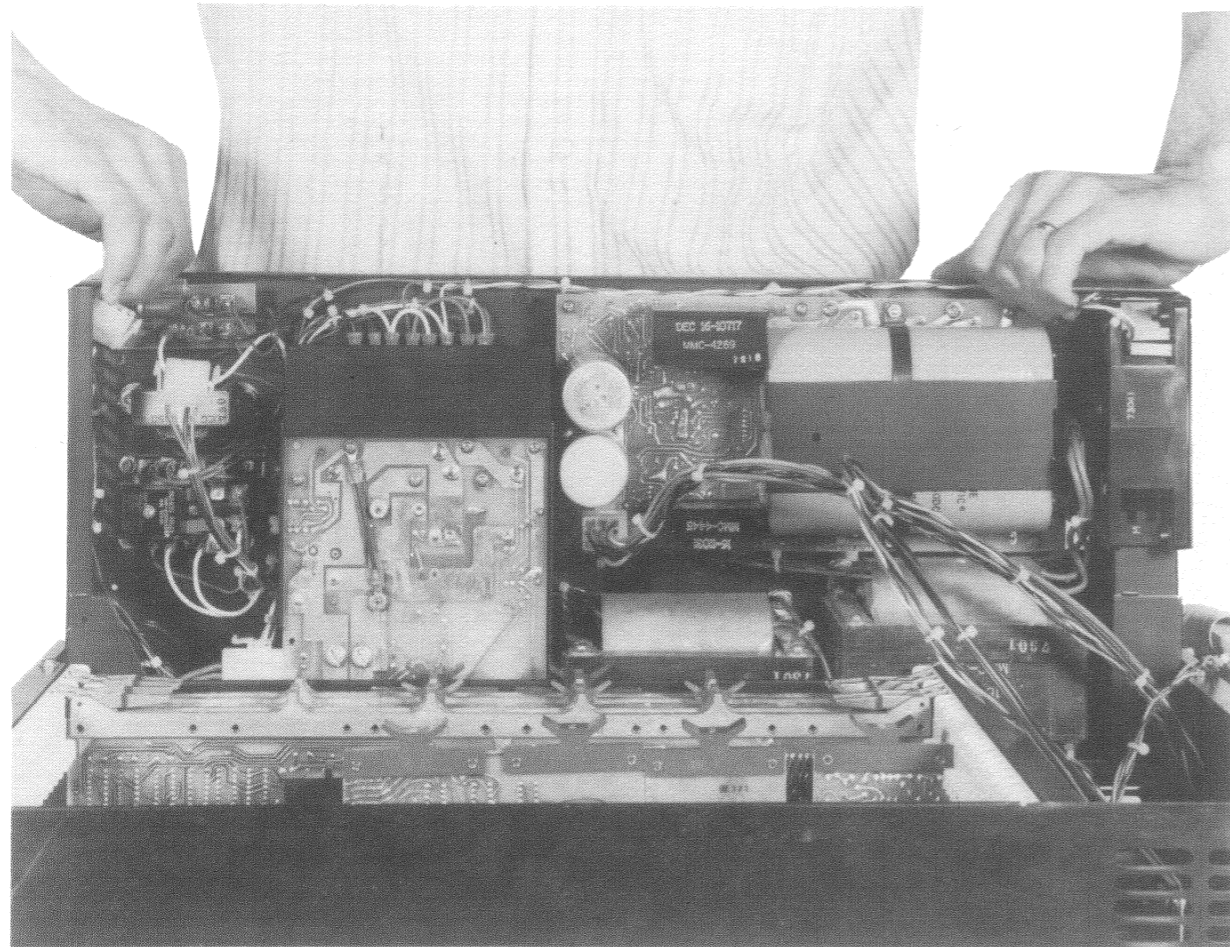

6712-7

Figure 3-28 Lifting Power Supply From Mounting Box

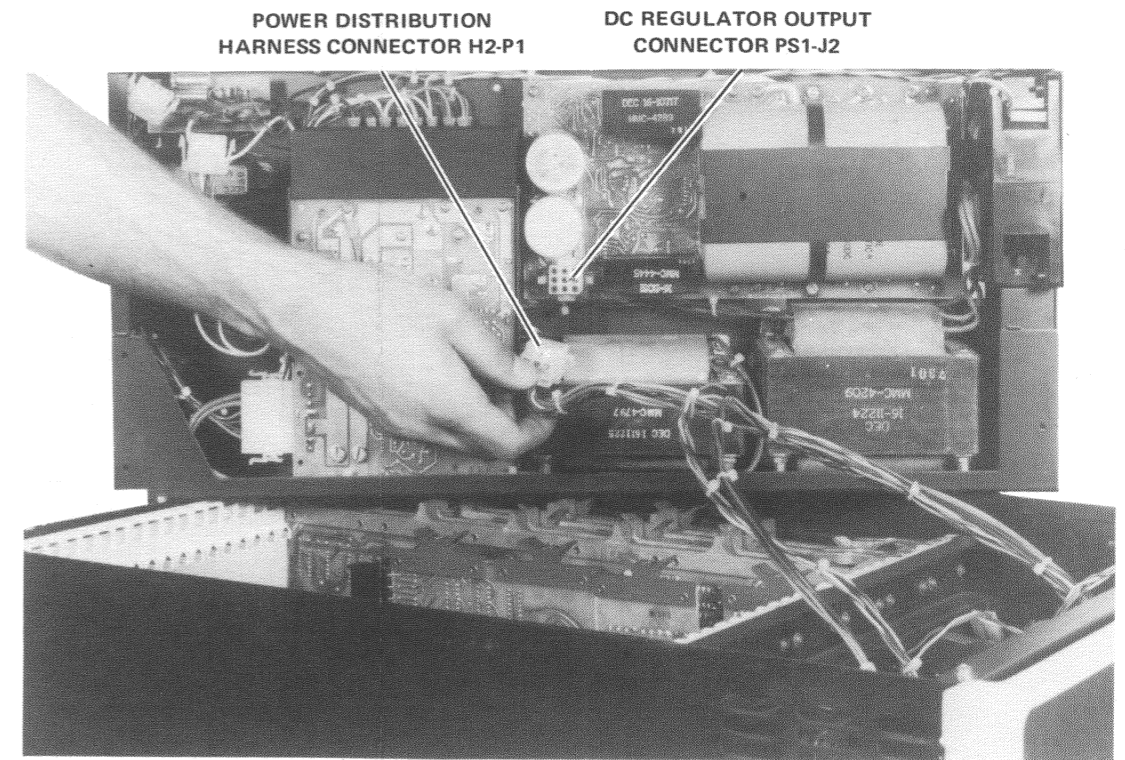

6712-8

Figure 3-29 Disconnecting DC Regulator Output Connector

3.5.4 Troubleshooting Procedures

3.5.4.1 Introduction – Most of the troubleshooting information presented relates to the components 5409728 Regulator and H744 Regulator.

Troubleshooting the other power system components such as the line set, relay, transformers, connectors, etc., can be accomplished by performing an electrical continuity check using the power system interconnection diagram (Figure 3-10).

3.5.4.2 Troubleshooting Hints

WARNING

Dangerous voltages (115 or 230 Vac) are present in the power system. Be careful when servicing these circuits.

Because of the physical configuration of the power supply, very little troubleshooting can be performed with the power supply installed. Voltages can be checked under load on the pin side of the computer backplane. For some malfunctions, the problem can be isolated to the load or power supply by disconnecting the backplane cable and checking the power supply outputs at the power distribution board connectors. Refer to the power distribution board circuit schematic (Figure 3-13) and list of signals (Table 3-1).

The most likely source of a power supply malfunction is the 5409728 Regulator or the H744 Regulator. A quick remedy for a malfunction in either of these regulators is to replace the complete unit. The replacement regulator may need adjustment to compensate for the load. If the new regulator is initially adjusted too high, it may activate the crowbar circuit. In the case of the H744 Regulator, no output is generated. In the case of the 5409728 Regulator, no output is generated and the +5 V fuse or -15 V fuse blows. If this should happen, remove power and rotate the appropriate voltage adjustment fully counterclockwise. Replace the fuse, if required, and apply power. Adjust the output to the recommended value per Paragraph 3.5.2.

NOTE

When replacing or swapping the 5409728 DC Regulator (PS1), etch revision D or later must be used. Earlier etch revisions, such as revision C which is used in the 5-1/4 in. PDP-11/05, 11/10 Computer, must not be installed because of insufficient current capacity.

3.5.4.3 Troubleshooting the 5409728 Regulator – Table 3-3 is a troubleshooting chart for the 5409728 Regulator. It should be used with Figures 3-15 through 3-19 or regulator schematic drawing D-CS-5409728-0-1 in the print set.

A visual check is a valuable aid in locating the cause of a malfunction. Check for loose connections, burned resistors, burned printed circuit board etch, cracked transistors or leaky capacitors.

As an additional aid to troubleshooting the 5409728 Regulator, waveform photos are provided for the +5 V and -15 V outputs. These waveforms were taken on a Tektronix Model 453 Oscilloscope. All waveforms are with respect to power common (J2 pin 2).

**Table 3-3
5409728 Regulator Troubleshooting Chart**

Problem	Cause
No +5 V and +15 V output	F1 open D14 or transformer T1 open +5 V adjusted too high*
+5 V Output Too Low	Q5, D9, Q10, Q9, Q11, D12, or D10 shorted C5 or C7 shorted R49, R50, R46, or R44 open Q6, Q7, Q8, or D11 shorted Q9, Q10, or D9 open* R51 or R50 open
+15 V Output Too High	Q1 shorted D8 open R35 or R36 open
No -15 V Output	F2 open D14 or transformer T1 open
-15 V Output Too Low	-15 V adjusted too high* Q25, D4, Q26, Q21, Q27, D7, or D5 shorted C14 or C12 shorted R22, R26, R25, or R29 open Q22, Q23, Q24, or D6 shorted Q25, Q26, or D4 open
BUS AC LO L Will Not Go High	Q13, Q14, or Q15 shorted Q16 or D3 open R7, R3, R6, or R8 open C9 shorted
BUS AC LO L Will Not Go Low and/or acts erratically on poweron/poweroff	Q13, Q14, or Q16 open Q15 or D3 shorted R12, R13, R7, or R10 open
BUS DC LO L Will Not Go High	Q19, Q20, or Q18 shorted Q17 or D3 open R7, R2, or R6 open C9 shorted
BUS DC LO L Will Not Go Low	Q19, Q20, or Q17 open Q18 or D3 open R7, R3, or R6 open C9 shorted

Table 3-3 (Cont)
5409728 Regulator Troubleshooting Chart

Problem	Cause
BUS DC LO L Will Not Go Low and/or acts erratically on poweron/poweroff	Q19, Q20, or Q17 open Q18 or D3 shorted R9, R10, R11, or R8 open
No LTC L Signal	R55 open D13 shorted
LTC L Going Too High	D13 open

*These causes make the crowbar fire, which, in turn, blows the appropriate fuse.

Figure 3-30 shows six waveforms for the +5 V output taken at points A and B in the circuit (Figure 3-18). Point A is the output of pass transistor Q6 and point B is the +5 V output (J2 pin 3). Waveforms a, b, and c are taken at point A and waveforms d, e, and f are taken at point B. Figure 3-31 shows six waveforms for the -15 V output taken at points C and D in the circuit (Figure 3-19). Point C is the output of pass transistor Q22 and point D is the -15 V output (J2 pin 9). Waveforms a, b, and c are taken at point C and waveforms d, e and f are taken at point D.

3.5.4.4 Troubleshooting the H744 Regulator – The design of the +5 V H744 Regulator is similar to the +5 V portion of the 5409728 Regulator. In general, the same troubleshooting procedures and fault isolation techniques apply to both regulators.

Some specific troubleshooting procedures are listed for the H744. Refer to Figure 3-21 which is the H744 circuit schematic.

- a. A regulator that provides no output, or low output, without causing fuse F1 to blow is probably working into a short-circuited output. Check for a short circuit in the load or a component failure in the crowbar circuit.
- b. A regulator that provides no output and has fuse F1 blown usually indicates a fault in the pass transistor or its driver network. Proceed as follows:
 1. Check for scorching of the etched board in the area of Q3 and Q4. Check the associated base-emitter bleeder resistors for damage.
 2. Check pass transistor Q2, drive transistors Q3 and Q4, and level shifter Q5 with an ohmmeter. The fault could be caused by continuous base drive to Q4.
 3. The fault could be caused by an external short-circuit that holds precision voltage regulator E1 in conduction. E1 pin 4 to ground should measure approximately 20K Ω . E1 pin 5 to ground should measure approximately 1.5K Ω .
 4. Check for shorts to ground at the fuse terminals and components mounted on the heat sink.

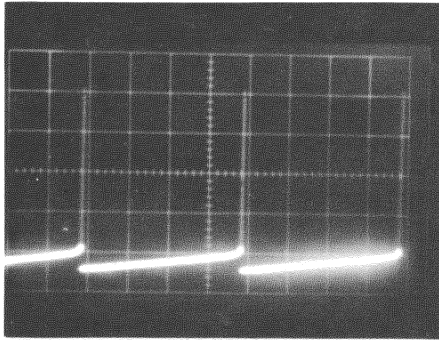

a) Point A, No load,
2 ms/div, and
10V/div.

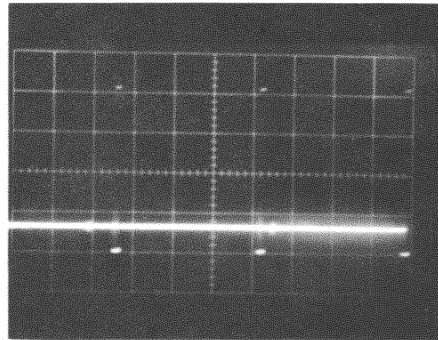

d) Point B, No load,
2 ms/div, and
50 mV/div.

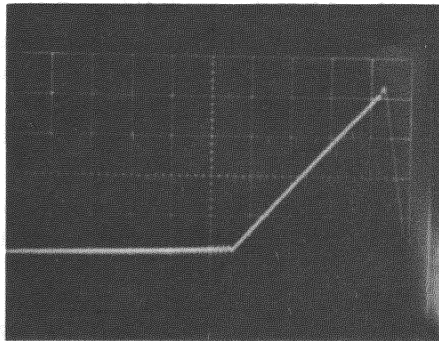

b) Point A, No load,
20 μ s/div, and
10V/div.

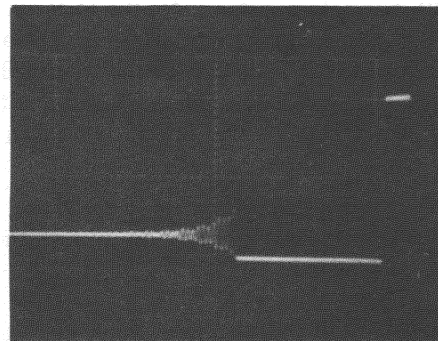

e) Point B, No load,
20 μ s/div, and
50 mV/div.

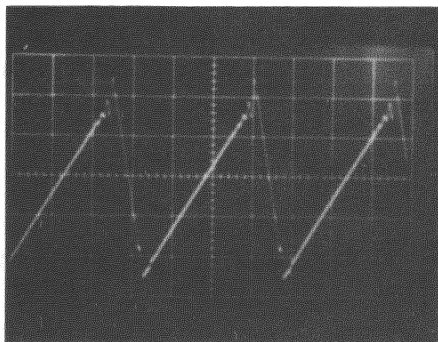

c) Point A, 20A load,
20 μ s/div, and
10V/div.

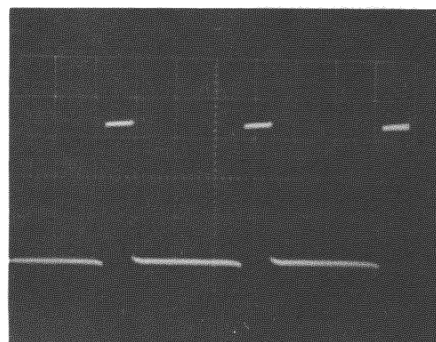

f) Point B, 20A load,
 μ s/div, and
50 mV/div.

Figure 3-30 +5 V Regulator Circuit Waveforms

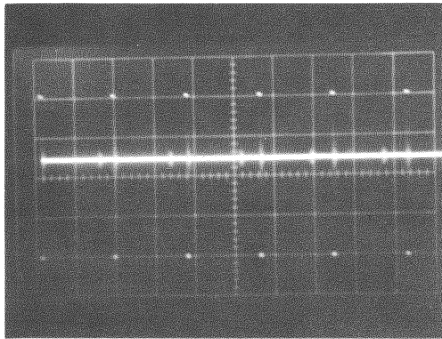

a) Point C, No load,
5 ms/div, and
10V/div.

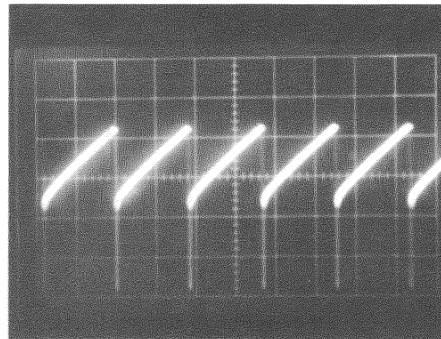

d) Point D, No load,
5 ms/div, and
50 mV/div.

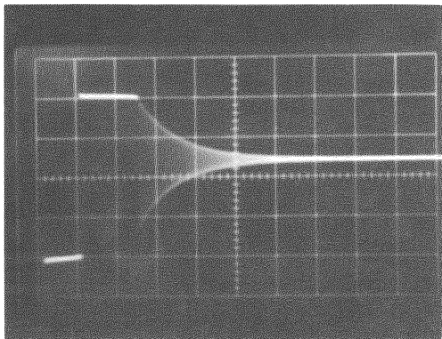

b) Point C, No load,
50 μ s/div, and
10V/div.

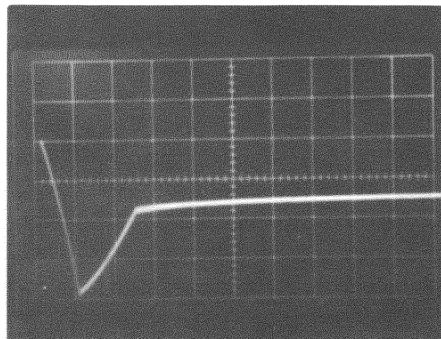

e) Point D, No load,
50 μ s/div, and
50 mV/div.

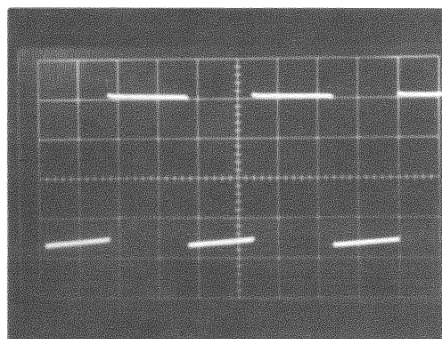

c) Point C, 5A load,
50 μ s/div, and
10V/div.

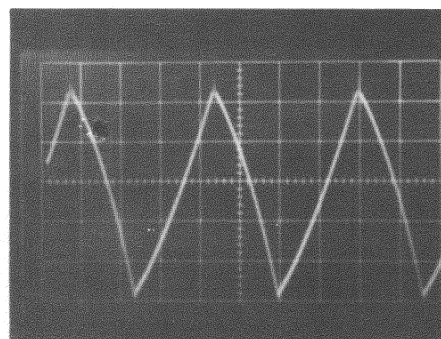

f) Point D, 5A load,
50 μ s/div, and
50 mV/div.

Figure 3-31 -15 V Regulator Circuit Waveforms

APPENDIX A

DC REGULATOR 5409728 SPECIFICATIONS

This appendix gives the detailed specifications for the 5409728 DC Regulator. They are tabulated by categories: input, output, and mechanical, and environmental.

Table A-1
Input Specifications

Parameters	Specifications
Input Voltage (1 phase, 2 wires and ground)*	95–135/190–270 V
Input Frequency	47–63 Hz
Input Current	5/2.5 A rms
Input Power	325 W at full load
Inrush	80/40 A peak, 1 cycle
Rise Time of Output Voltages	30 ms max. at full load, low line
Input Overvoltage Transient	180/360 V, 1 second 360/720 V, 1 ms
Storage After Line Failure	25 ms min., starting at low line, full load
Input Breaker (part of BC05 line set)	10 A/5 A single-pole, manually reset, thermal
Thermostat Mounted on heat sink (opens transformer and fan power)	277 V, 7.2 A contacts Opens 98°–105° C Automatically resets 56°–69° C
Input Connections	Line cord on BC05 line set, length and plug type specified with BC05
Turn-On/Turn-Off	Application or removal of power
Hipot (input to chassis and output)	2.1 kV/dc, 60 seconds

*Input voltage selection, 115 or 230 V, is made by specifying the appropriate line set, DEC Model BC05T or BC05U. All specifications are with respect to the BC05 input.

**Table A-2
Output Specifications**

Parameter	Specification
+15 V	
Load Range	
Static	0–1 A
Dynamic	0–1 A
Max. Bypass Capacitance in load for 30 ms turn-on	500 mF
Overvoltage protection	None
Current limit at 25° C	1.3 A to 1.7 A (–6.2 mA/° C)
Backup Fuse	15 A (also used for +5 V)
Adjustment	±5% min.
Regulation (All causes including line, load, ripple, noise, drift, ambient temperature)	±5%
+5 V	
Load Range	
Static	0–15 A
Dynamic #1	±5 A (within 0–17 A load range)
Dynamic #2	No load – full load
Max. Bypass Capacitance in load for 30-ms turn-on	2000 μF
Overvoltage Crowbar (blows fuse)	5.7–6.8 V actuate (7 V abs. max. output)
Current Limit at 25° C	24–29.4 A (–0.1 A/° C)
Backup Fuse (series with raw dc)	15 A
Adjustment Range	±5% min.
Regulation	
Line	±0.5%
Static Load	3%
Dynamic Load #1	±2%
Dynamic Load #2	±10%
Ripple and Noise	4% peak-to-peak
1000 Hour Drift	±0.25%
Temperature (0–60°)	±1%

Table A-2 (Cont)
Output Specifications

Parameter	Specification
- 15 V	
Load Range	
Static	0–7 A
Dynamic #1	$\Delta I = 5 \text{ A}$ (0.5 A/ μs)
Dynamic #2	No load – full load (0.5 A/ μs)
Max. Bypass Capacitance in load for 30-ms turn-on	1000 μF
Overvoltage Crowbar (blows fuse)	17.4–20.5 V (22 V abs. max. output)
Current Limit at 25° C	10–13.3 A (–0.03 A/° C)
Backup Fuse (series with raw dc)	5 A
Adjustment Range	$\pm 5\%$ min.
Regulation	
Line and Static Load	$\pm 1\%$
Dynamic Load #1	$\pm 2.5\%$
Dynamic Load #2	$\pm 3\%$
Ripple and Noise	3% peak-to-peak
1000 Hour Drift	$\pm 0.25\%$
Temperature (0–60° C)	$\pm 1\%$
BUS DC LO L and BUS AC LO L	
<i>Static Performance at Full Load</i> (for 230 V connection, double voltages below)	
BUS DC LO L goes to high	74–80 Vac line voltage
BUS AC LO L goes to high	8–11 V higher
BUS AC LO L drops to low	80–86 Vac line voltage
BUS DC LO L drops to low	7–10 V lower
Hysteresis (contained in above specifications)	3–4 Vac
Output voltages still good	70 Vac line voltage

**Table A-2 (Cont)
Output Specifications**

Parameter	Specification
BUS DC LO L and BUS AC LO L (Cont)	

Dynamic Performance

Worst case on power-up is high line, full load.

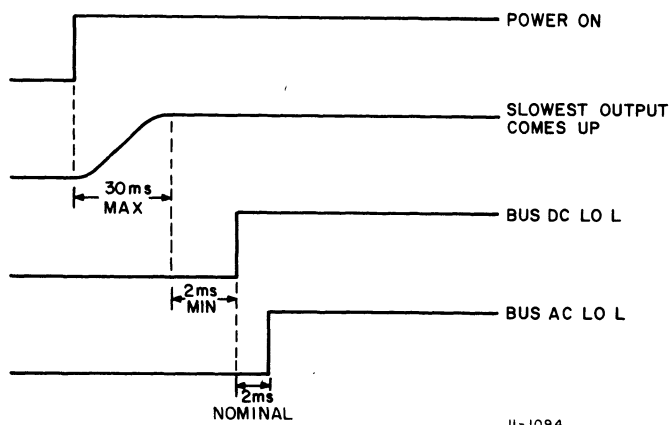

II-1094

Worst case on power-down is low line, full load.

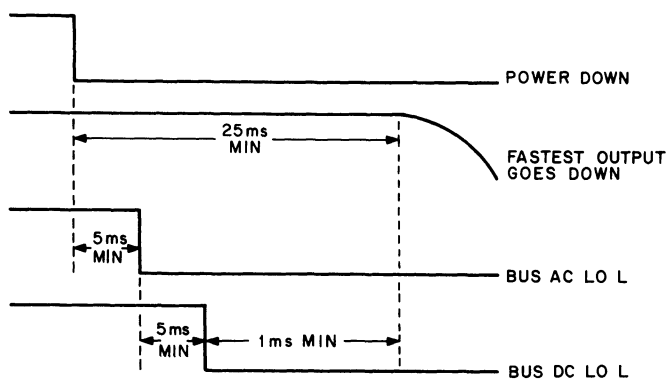

II-1099

Output Characteristics

Open Collector	50 mA sinking capability +0.4 V max. offset
Pull-Up Voltage on Unibus	5 V nominal, 180 Ω impedance
Rise and Fall Times	1 μ s max. Outputs shall remain in 0 state subsequent to power failure until power is restored despite Unibus pulling voltages remaining.

**Table A-3
Mechanical and Environmental Specifications**

Parameter	Specification
Weight	7 lb approx. 18 lb approx.
Dimensions	10.50 in. length 5.19 in. width 3.25 in. height
Minimum Cooling Requirements	375 ft ³ /min through heat sink 250 ft ³ /min over caps, chokes, and transformer
Rated Heat Sink Temperature	95° C max.
Shock, Non-Operating	40 G (duration 30 ms) 1/2 sine in each of six orientations
Vibration, Non-Operating	1.89 G rms average, 8 G peak; varying from 10 to 50 Hz, 8 dB/octave roll-off 50–200 Hz; each of six directions
Ambient Temperature	0 to +60° C operating -40 to +71° C storage
Relative Humidity	95% max. (without condensation)
Altitude	10K ft

APPENDIX B

CABLE CONNECTORS

B.1 INTRODUCTION

This appendix lists the pin and signal designations for the serial communications line (SCL) interface, console cable, and Unibus cable/jumper.

B.2 SERIAL COMMUNICATIONS LINE INTERFACE

Identification of the SCL interface is covered in detail. The 70-08360 SCL cable contains an 8-pin Mate-N-Lok connector on one end that mates with the cable on the serial communications device. The other end contains a 40-pin Berg female connector that mates with a 40-pin Berg male connector on the M9970 Cable Card that is inserted in slots C1-D1 in the computer backplane. The signals are wired, via the pin side of the backplane, to the M7260 Data Paths module. Table B-1 contains pin and signal designations at these points and a description of each signal. Figure B-1 shows the 70-08360 cable and Berg connector on the M9970.

B.3 CONSOLE CABLE

Console cable BC08R-03 is a 3-ft flat cable with 40-pin female Berg connectors on each end. Table B-2 lists the pin and signal designations for the console cable.

B.4 UNIBUS CABLE/JUMPER

Table B-3 lists the pin and signal designations for the Unibus BC11A Cable and Unibus M920 Jumper.

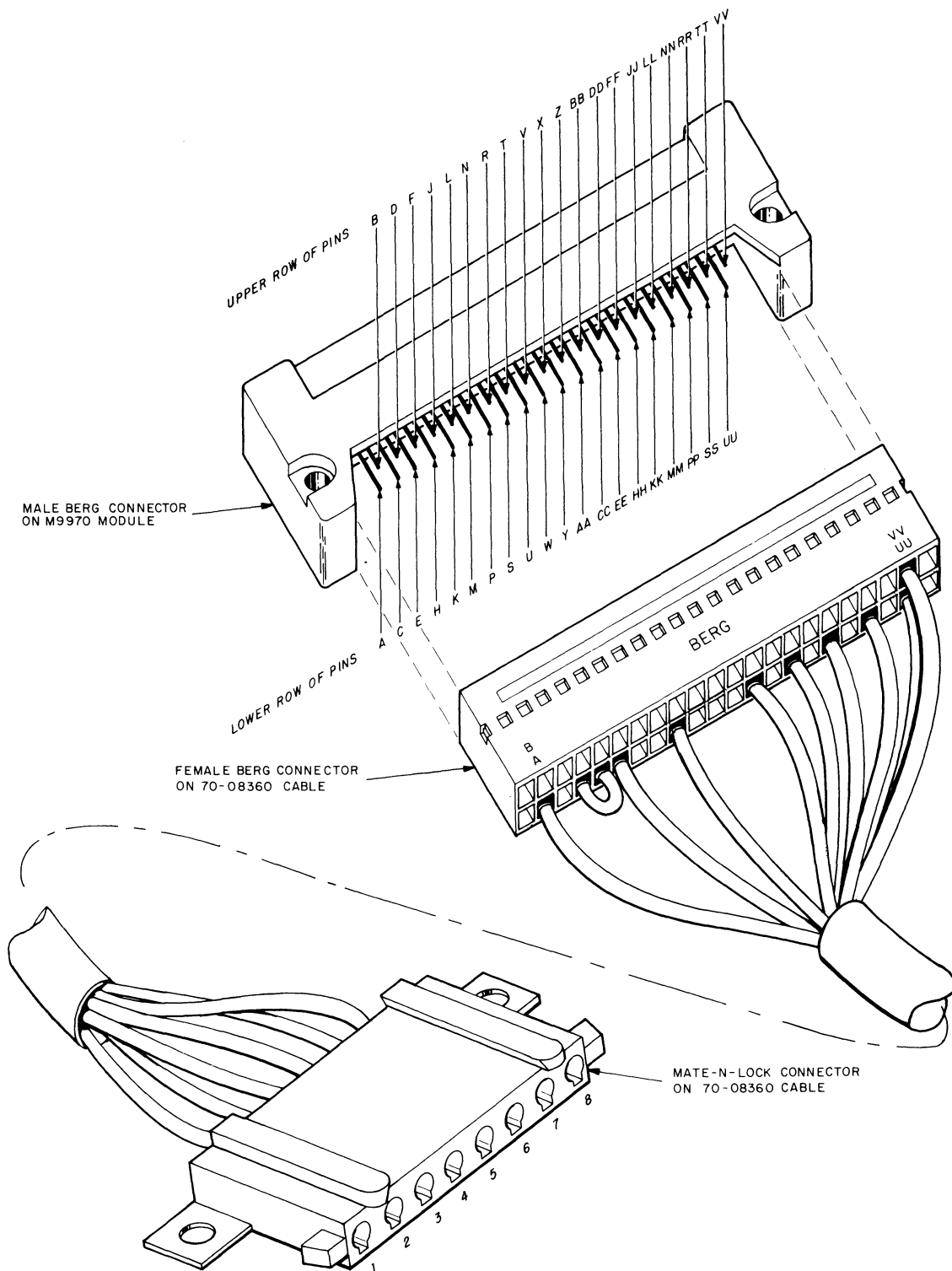

11-2076

Figure B-1 SCL Cable 70-08360

Table B-1
SCL Interface Pin and Signal Designations

70-08360 CABLE SIGNAL NAME	MATE-N-LOK PIN ON 70-08360 CABLE	BERG PIN ON 70-08360 CABLE	BERG PIN ON M9970 CABLE CARD	SIGNAL NAME ON M7260 MODULE	M7260 PIN	SIGNAL DESCRIPTION
SER 0 + (20 mA)	5	AA	AA	DPH SER 0 L	FE2	+20 mA SERIAL OUT (from computer)
SER 0 - (20 mA)	2	KK	KK	DPH SER 0-15 L	FJ2	-20 mA SERIAL OUT
SER IN + (20 mA)	7	K	K	DPH SER IN H	FN1	+20 mA SERIAL IN (to computer)
SER IN - (20 mA)	3	S	S	DPH SI-15 L	FP1	-20 mA SERIAL IN
READER RUN + (20 mA)	6	PP	PP	DPH RDR ENAB L	FK2	+20 mA TTY READER ENABLE
READER RUN - (20 mA)	4	EE	EE	DPH RE -15 L	FR1	-20 mA TTY READER ENABLE
SER 0 (TTL)	-	SS	SS	DPH SER 0 H	DF1	SERIAL DATA OUT (from computer) NOTE 1
SER IN (TTL)	-	E	E	FS SER IN H	FM1	SERIAL DATA IN (to computer) NOTE 1
CLK IN (TTL)	-	CC	CC	FS CLK L	FH1	EXTERNAL CLOCK INPUT FOR SCL NOTE 1,2
CLK DISAB (TTL)	-	HH	HH	FS CLK DISAB L	FH2	DISABLE LINE FOR INTERNAL SCL NOTE 1,3 CLOCK
20 mA INTERLOCK	-	H,E	-	-	-	NOT USED ON THIS INTERFACE
+5 V	-	TT	TT	-	-	+5 V POWER AVAILABLE EXTERNALLY
+15 V	-	U	U	-	-	+15 V POWER AVAILABLE EXTERNALLY
GROUND	-	A,B,UU,VV	A,B,UU,VV	-	-	LOGIC GROUND

NOTE 1: These signals are TTL compatible.

NOTE 2: Externally supplied SCL CLOCK must be 16 times desired buad rate
(max. baud rate is 10,000 baud).

NOTE 3: This signal must be asserted low to disable internal clock if the external TTL CLOCK is to be used.

Table B-2
BC08R-03 Console Cable Pin
and Signal Designations

Designations	
Pin	Signals
PP	DAK H
BB	SW 15 (1) H
DD	SW 14 (1) H
FF	SW 13 (1) H
JJ	SW 12 (1) H
LL	SW 11 (1) H
NN	SW 10 (1) H
RR	SW 09 (1) H
TT	SW 08 (1) H
J	SW 07 (1) H
L	SW 06 (1) H
N	SW 05 (1) H
R	SW 04 (1) H
T	SW 03 (1) H
V	SW 02 (1) H
X	SW 01 (1) H
Z	SW 00 (1) H
HH	SCAN ADRS 01 (1) L
KK	SCAN ADRS 02 (1) L
MM	SCAN ADRS 03 (1) L
SS	SCAN ADRS 04 (1) L
CC	PUP L
C	RUN L
E	KEY LOAD ADRS (1) L
H	KEY EXAM (1) L
K	KEY CONT (1) L
M	KEY HLT ENB (1) L
P	KEY START (1) L
S	KEY DEP (1) L

Table B-3
Unibus BC11A Cable/M920 Jumper
Pin and Signal Designations

Designation		Designation	
Pin	Signals	Pin	Signals
AA1	INIT L	BA1	BG 6 H
AA2	POWER (+5 V)	BA2	POWER (+5 V)
AB1	INTR L	BB1	BG 5 H
AB2	GROUND	BB2	GROUND
AC1	D00 L	BC1	BR 5 L
AC2	GROUND	BC2	GROUND
AD1	D02 L	BD1	GROUND
AD2	D01 L	BD2	BR 4 L
AE1	D04 L	BE1	GROUND
AE2	D03 L	BE2	BG 4 H
AF1	D06 L	BF1	AC LO L
AF2	D05 L	BF2	DC LO L
AH1	D08 L	BH1	A01 L
AH2	D07 L	BH2	A00 L
AJ1	D10 L	BJ1	A03 L
AJ2	D09 L	BJ2	A02 L
AK1	D12 L	BK1	A05 L
AK2	D11 L	BK2	A04 L
AL1	D14 L	BL1	A07 L
AL2	D13 L	BL2	A06 L
AM1	PA L	BM1	A09 L
AM2	D15 L	BM2	A08 L
AN1	GROUND	BN1	A11 L
AN2	PB L	BN2	A10 L
AP1	GROUND	BP1	A13 L
AP2	BBSY L	BP2	A12 L
AR1	GROUND	BR1	A15 L
AR2	SACK L	BR2	A14 L
AS1	GROUND	BS1	A17 L
AS2	NPR L	BS2	A16 L
AT1	GROUND	BT1	GROUND
AT2	BR 7 L	BT2	C1 L
AU1	NPG H	BU1	SSYN L
AU2	BR 6 L	BU2	C0 L
AV1	BG 7 H	BV1	MSYN L
AV2	GROUND	BV2	GROUND

LEADER'S COMMENTS

**PDP-11/05, 11/10
SUPPLEMENT 1
DEC-11-H05AA-B-D**

Your comments and suggestions will help us in our continuous effort to improve the quality and usefulness of our publications.

What is your general reaction to this manual? In your judgment is it complete, accurate, well organized, well written, etc.? Is it easy to use? _____

What features are most useful? _____

What faults do you find with the manual? _____

Does this manual satisfy the need you think it was intended to satisfy? _____

Does it satisfy *your* needs? _____ Why? _____

Would you please indicate any factual errors you have found. _____

Please describe your position. _____

Name _____ Organization _____

Street _____ Department _____

City _____ State _____ Zip or Country _____

Fold Here

Do Not Tear - Fold Here and Staple

**FIRST CLASS
PERMIT NO. 33
MAYNARD, MASS.**

**BUSINESS REPLY MAIL
NO POSTAGE STAMP NECESSARY IF MAILED IN THE UNITED STATES**

Postage will be paid by:

Digital Equipment Corporation
Technical Documentation Department
146 Main Street
Maynard, Massachusetts 01754

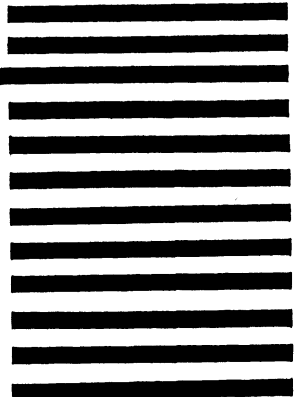

**description of data paths
module M7260 revision M**

1st Edition, August 1973
2nd Printing, September 1973
3rd Printing, July 1974

Copyright © 1973, 1974 by Digital Equipment Corporation

The material in this manual is for informational purposes and is subject to change without notice.

Digital Equipment Corporation assumes no responsibility for any errors which may appear in this manual.

Printed in U.S.A.

The following are trademarks of Digital Equipment Corporation, Maynard, Massachusetts:

DEC	PDP
FLIP CHIP	FOCAL
DIGITAL	COMPUTER LAB
UNIBUS	

INTRODUCTION

This publication is a supplement to the *PDP-11/05, 11/10 Computer Manual* (DEC-11-H05AA-B-D). It discusses the differences between the latest M7260 Data Paths Module (Revision M) and previous M7260 modules. This latest module is manufactured to etch board revision C, which has a completely different layout than previous modules.

All revisions of the M7260 module are functionally interchangeable. The M revision contains several circuit improvements and uses medium scale integration (MSI) to perform some functions that were performed previously by small scale integration (SSI). Substitution of MSI devices for SSI devices produces less interconnections.

The functional operation of this module is described in Chapter 8 KD11-B Detailed Description and Chapter 9 Microprogram Control of the referenced manual. Because of the new layout, the component designations (E numbers) on the M revision module are different than those referenced in the *PDP-11/05, 11/10 Computer Manual*, DEC-11-H05AA-B-D.

This supplement discusses only the significant changes that occur in the M revision. Each change is discussed as a separate item. Detailed logic prints are included in the separately supplied print set; specifically, drawing D-CS-M7260-0-1 Rev M, Sheets 1–12. Revision F is the previous module referenced in the discussion.

1. Use of Resistor Network Instead of Discrete Resistors for Pull Up/Pull Down

Resistors network, part number 1311003-02, is used instead of discrete pull up/pull down resistors. It is a hybrid thick film resistor divider network in a 16-pin DIP. The package consists of 14 identical circuits (Figure 1). Each circuit consists of an R1 resistor (330 Ω) and R2 resistor (680 Ω) connected in series between +5 V and ground. Connection to the logic device is made between R1 and R2.

Four networks (E042, E045, E060, E084) are used on the module. Refer to drawing D-CS-M7260-0-1, Rev M, sheets 4, 5, 6, 7, 9, and 10.

2. Use of 8838 Quad Bus Transceivers Instead of 380 Quad Bus Receivers and 8881 Quad Bus Drivers

Four 8838 quad bus transceivers replace four 380 quad bus receivers and four 8881 quad bus drivers. Sixteen Unibus receivers/drivers are contained in four 16-pin DIP ICs instead of eight 14-pin DIP ICs. Figure 2 shows a signal/pin designation diagram for the 8838 and a schematic of one transceiver with the common driver enabling gate.

These devices are designated E01, E02, E03, and E05. Refer to drawing D-CS-M7260-0-1, Rev M, sheets 4, 5, 6, and 7.

3. Addition of Switch Register Multiplexers in ALEG at Output of Scratch Pad Memories

Four 8266 2-input, 4-bit multiplexers have been added between the scratch pad memories and the arithmetic logic units (ALU). Each multiplexer is identified as SWITCH REG MUX. They are designated E033, E034, E035, and E036. Refer to drawing D-CS-M7260-0-1, Rev M, sheets 4, 5, 6, and 7.

Figure 3 shows SWITCH REG MUX E036 for ALEG bits 00–03. The switch register signals from the console cable are sent directly to the A inputs of E036. In earlier modules, the switch register signals were sent to 74H01 NAND gates that were wired-ORed to the ALEG. These gates have been removed in the revision M module.

The outputs of SPM E040 are sent to the B inputs of SWITCH REG MUX E036. Input selection (A or B) is made by select lines S1 and S0. The multiplexer outputs are sent to the A inputs of ALU E027.

The scratch pad memories E037, E038, E039, and E040 have been changed from type 3101A to type 7489, which are less expensive devices.

4. Addition of BLEG Multiplexer for BLEG Bits 00–03

A type 74S158 2-line to 1-line multiplexer (E021) has been added to the output of BREG E015, which handles BLEG bits 00–03 (Figure 4). It replaces five type 74H01 NAND gates and four pull-up resistors that are used in earlier modules. Refer to drawing D-CS-M7260-0-1, Rev M, sheet 4.

The three operating modes of the BLEG that provide input data to the ALU remain the same. The modes are: BREG unmodified, sign extend BREG, and generation of the constant +1.

5. Provision for Adding a CONSTANTS ROM for ALEG Bits 08–15.

Provisions have been made in the etched circuit at location E043 to accommodate a 32 \times 8 bit ROM. This ROM would serve as a constants generator for ALEG bits 08–15. Refer to drawing D-CS-M7260-0-1, Rev M, sheet 6.

6. Changes In Auxiliary Control Logic and Processor Status Word Logic

The basic enabling signal for the auxiliary control mode is CONF AUX CONTROL L. The pulse width of this signal has been extended to 600 ns. This provides adequate time for the inputs to CC MUX multiplexer E062 and C & V BIT ROM E060 to settle. This allows removal of the two type 74174 hex flip-flops that are used in earlier modules to delay these input signals.

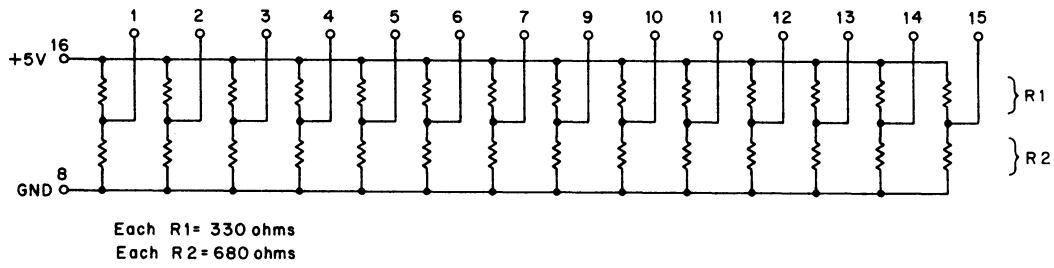

Circuit Schematic

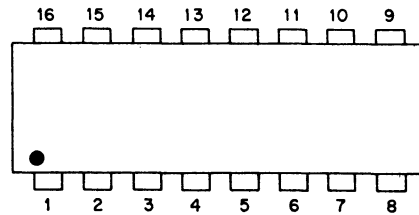

Pin Designations

11-2083

Figure 1 Resistor Network (1311003-02) Circuit Schematic and Pin Designations

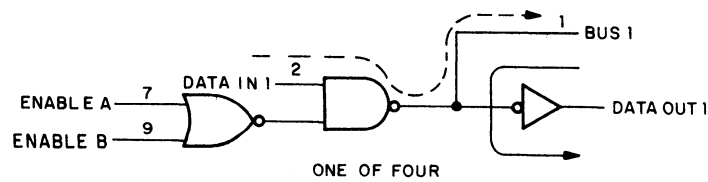
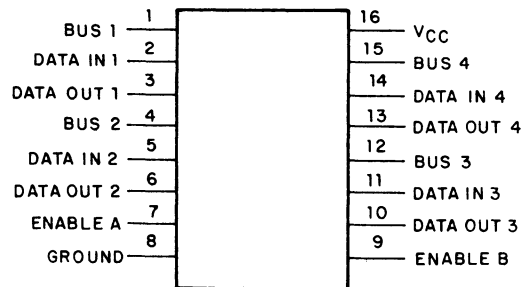

11-1860

Figure 2 8838 Quad Bus Transceivers

In the processor status word (PSW) logic, type 74175 quad flip-flop E056 replaces three type 7474 D-type flip-flops. Refer to drawing D-CS-M7260-0-1, Rev M, sheet 8. The flip-flops are associated with the N, Z, and V bits of the PSW. The function of the logic has not changed. Use of the 74175 requires fewer interconnections on the module. A few additional minor changes to the PSW logic are described below.

- a. CC MUX E062 has its enable (E) input permanently connected to ground. When the select (S) input is low, input word A is selected; and when S is high, input word B is selected. The select (S) signal is CONF AUX CONTROL L, rather than its delayed counterpart.
- b. Signal DPF C CLK L to E057 pin 12 is used rather than its delayed counterpart.

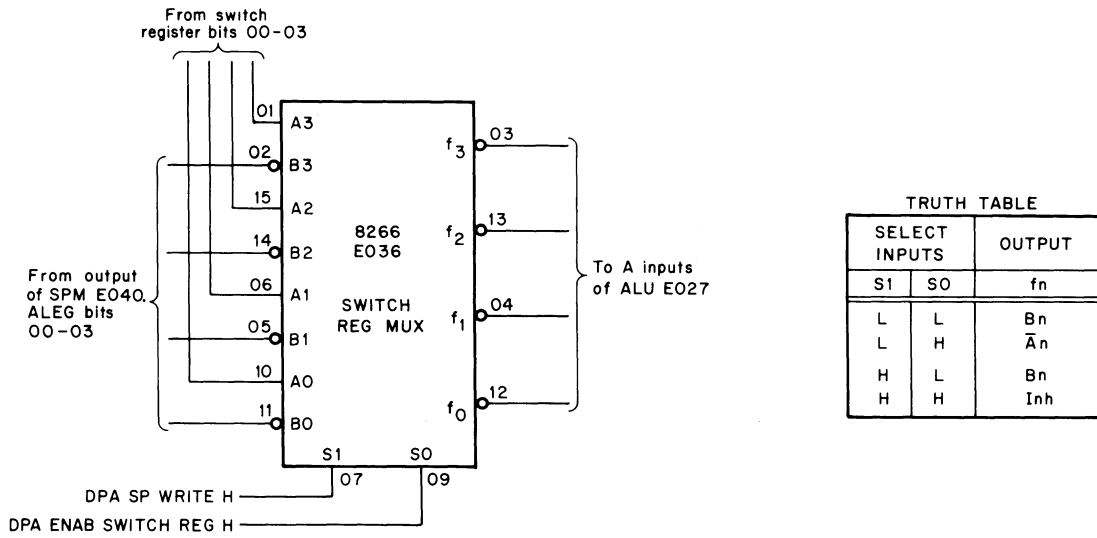

Figure 3 Typical Switch Register Multiplexer

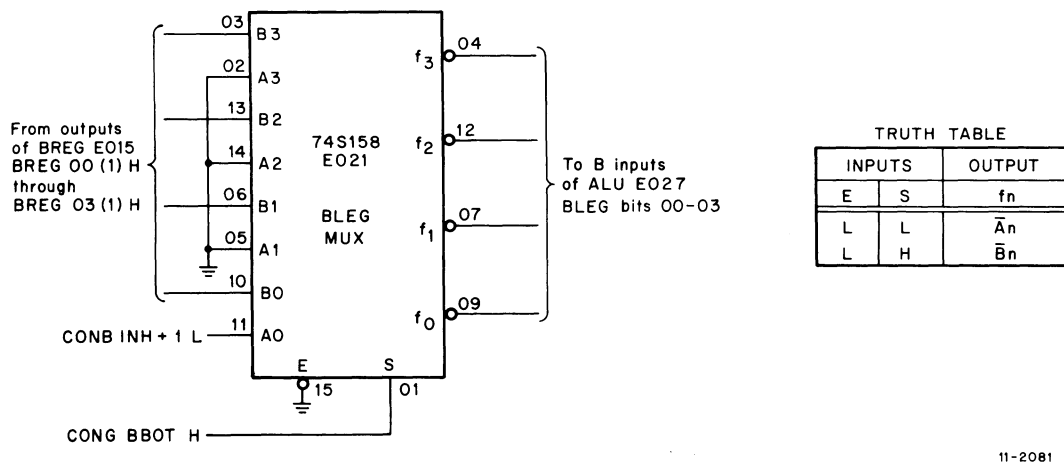

Figure 4 Multiplexer for BLEG Bits 00-03

7. Changes In the Serial Communications Line (SCL) Logic

Several changes have been made in the SCL logic. They are described below. The two most significant changes are a new oscillator and new baud selection logic. Refer to drawing D-CS-M7260-0-1, Rev M, sheets 11 and 12.

- a. To ensure proper set-up of the transmitter and receiver interrupt logic circuits, a different method is used to clear the TBMT and DA flip-flops (sheet 12). In previous modules, the TBMT flip-flop is cleared directly by the XMIT INT flip-flop. Similarly, the DA flip-flop is cleared directly by the RCD INT flip-flop. In the Rev M module, the TBMT and DA flip-flops are cleared at the same time as the XMIT INT and RCD INT flip-flops, respectively.
- b. Three outputs of the universal asynchronous receiver/transmitter (UART) are buffered by type 7408 AND gates (sheet 11). They are the serial output (SO), data available flag (DA), and the transmitter buffer empty flag (TMBT).
- c. Clock signal DPH TTY CLK H is brought out to module pin ED2 (sheet 11). This signal can be accessed on the pin side of the backplane during servicing.
- d. One-shot E076 has been added to provide a longer RDA (Received Data Available) pulse to the UART. When triggered, the one-shot generates a negative pulse of approximately 1.2 μ s duration.
- e. The Rev M module incorporates a new high stability oscillator (sheet 11).

Two type 9602 retriggerable one-shots are interconnected to form a simple oscillator that generates the SCL clock signal (Figure 5). The oscillator starts when signal DPH B INIT L is released (goes high) and is self-sustaining thereafter. It has a gated input that allows initialize signal DPH B INIT L to inhibit the clock when it is asserted.

Both 9602s are in the same package (E100) and are identified as A and B in this discussion. To ensure stability, the +5 V power to these one-shots is filtered by R22, R27, C111, and C112. The clear inputs (pins 03 and 13) are not used so they are permanently pulled up to +5 V.

Each one-shot triggers on a negative (falling) edge at input pin 05/11 while input 04/12 is held permanently low (connected to ground).

The output pulse width is determined by the RC network connected across pins 14/2 and 15/1. For one-shot B (pins 2 and 1), the values are chosen to provide a pulse width of 10 μ s. For one-shot A (pins 14 and 15), the pulse width is variable from about 22 to 44 μ s. Potentiometer R21 is used to perform the adjustment.

As power is applied and DPH B INIT L is asserted, both one-shots are at rest; therefore, the 0 output (pin 09) of one-shot A is high. This signal is sent to the triggering input of one-shot B and is also fed back to pin 13 of NAND gate E097. When DPH B INIT L is released (goes high), the output of E099 goes low and triggers one-shot A. A negative pulse is generated at the 0 output of one-shot A. Assume that R21 is adjusted to give a pulse width of 26 μ s. The negative-going leading edge of this pulse triggers one-shot B, which produces a 10 μ s positive pulse at its 1 output (pin 06). When one-shot A times out, its output goes high and, because of the feedback connection, it is triggered again. There is a delay of approximately 25 ns before it triggers again and subsequently causes one-shot B to trigger again. The pulse width of one-shot A determines the period of clock signal DPH TTY CLK (1) H. In this case, 10 μ s clock pulses are produced at a period of 26 μ s, which is a frequency of 38.4 kHz.

A simplified timing diagram is shown in Figure 5.

TRUTH TABLE FOR
9602 ONE-SHOT

INPUT PIN NO.		OUTPUT PIN NO.	
05/11	04/12	06/10	07/09
H	↑		
↓	L		

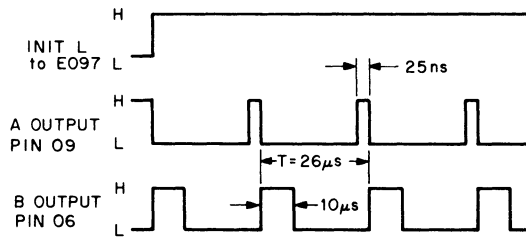
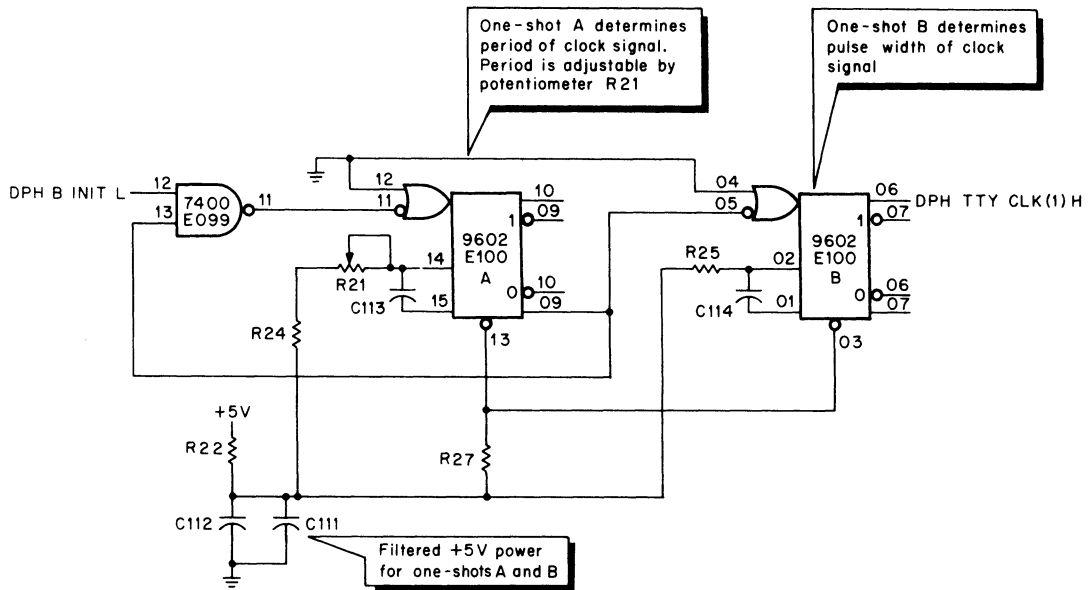

TIMING DIAGRAM

11-2084

Figure 5 SCL Oscillator Schematic and Timing Diagram

- f. The Rev M module incorporates switch selectable baud rates (sheet 11).

Signal DPH TTY CLK (1) H is used to create the clock for the universal asynchronous receiver/transmitter (UART). This signal is first sent to a counter whose outputs are selected by a switch to provide five different UART clock rates. The UART receiver and transmitter clocks must operate at a rate 16 times the value of the desired baud rate because the UART samples incoming data 16 times per second. The frequency in Hz of a particular UART clock is found by multiplying the desired baud rate by 16.

Signal DPH TTY CLK (1) H from the oscillator is sent to the clock 1 (C1) input of 4-bit binary counter E095 (Figure 6). It is a type 74197 that is connected as a 4-bit ripple-through counter. The clock input (C1) is divided by 2, 4, 8, and 16 at outputs R0(1), R1(1), R2(1) and R3(1), respectively. Load inputs D0, D1, D2, and D3 are all connected to ground so the counter cannot be preset. The counter is cleared (all outputs go to 0) when DPH B INIT L is asserted.

The oscillator output, DPH TTY CLK (1) H, and counter outputs are connected to a single pole rotary switch whose output is one of five frequencies as shown below:

Switch Position	Output Frequency
01	Oscillator
02	Oscillator ÷ 2
03	Oscillator ÷ 4
04	Oscillator ÷ 8
05	Oscillator ÷ 16

The switch output is sent to pin 01 of NAND gate E099. The other input (pin 02) of this gate is pulled high except when an external clock is used rather than the one on the M7260 module. Under these conditions, the clock signal as chosen by the switch appears inverted at the output (pin 03) of E099. This clock signal is sent to pin 04 of another E099 NAND gate, which is shown as the logically equivalent negative input OR gate. The other input (pin 05) of this gate is also high except when an external clock is used; therefore, the clock signal is inverted again and appears as DPH TTY CLK H at pin 06 of the second E099 gate. The signal clocks the UART receiver and transmitter and counter E088 which generates signal DPH START H.

Two commonly used baud ranges are obtained by selecting 26 μ s or 35.5 μ s as the period of the oscillator output (Table 1).

An external clock can be used instead of the clock on the M7260 module. The module clock is disabled by a low level on pin FH2 (Figure 6). The disabling signal is called FS CLK DISAB L. The external clock is connected to pin FH1 and is called FS CLK L. The inverted external clock signal appears at pin 06 of E099.

Table 1
Baud Selection

Switch Position	Range 1		Range 2	
	Baud	Period*	Baud	Period*
1 (OSC output)	2400	26 μ s	1760	35.5 μ s
2 (OSC ÷ 2)	1200	52 μ s	880	71 μ s
3 (OSC ÷ 4)	600	104 μ s	440	142 μ s
4 (OSC ÷ 8)	300	208 μ s	220	284 μ s
5 (OSC ÷ 16)	150	416 μ s	100	568 μ s

*Period of clock signal DPH TTY CLK H observed on backplane pin E02D2.

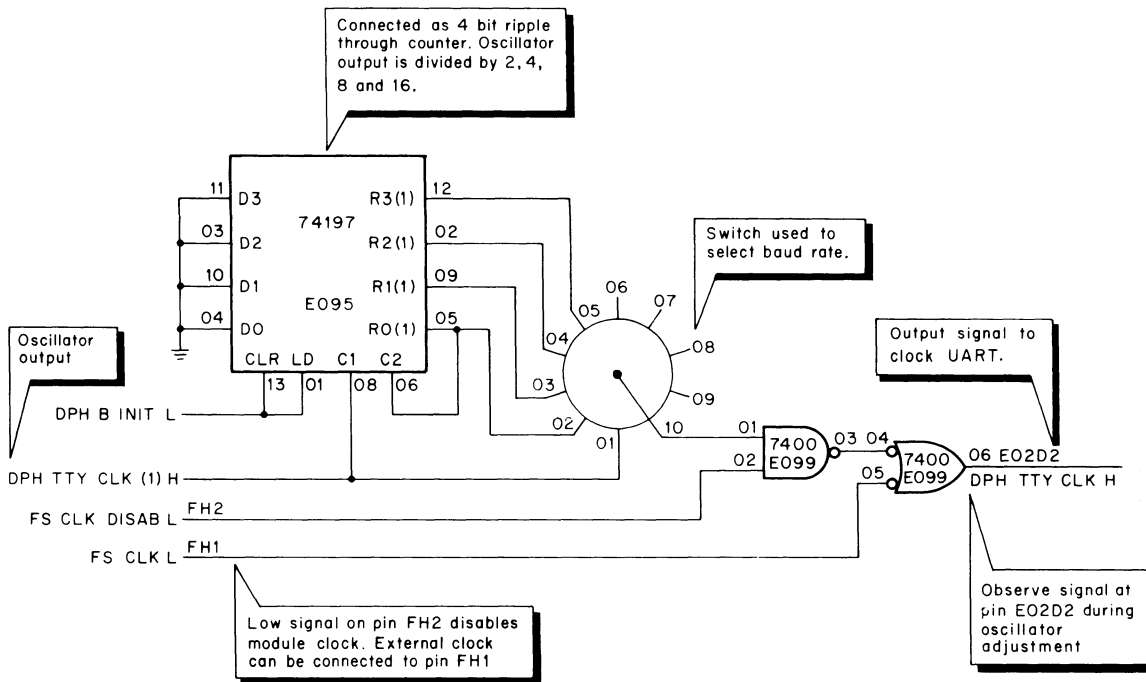

11-2080

Figure 6 Baud Selection Logic

BAUD RATE ADJUSTMENT

Use the following procedure to adjust the baud rate for the serial communications line.

1. Turn power off.
2. Extend the computer out of the cabinet until the chassis slide lock clicks.
3. Remove the mounting box top and bottom covers.
4. Remove the M7260 module. Using a small blade type screwdriver, turn the baud adjustment switch (S1) fully counterclockwise, which is position 1. Refer to Table 1 to determine the switch position for the selected baud rate. Set the switch to the proper position and insert the M7260 module into the backplane.
5. Turn power on.
6. Connect an oscilloscope probe to backplane pin E02D2 to observe signal DPH TTY CLK H (Figure 6). This is the UART clock signal; its frequency is 16 times the baud rate.

7. Adjust the SCL oscillator frequency to match the selected baud rate in accordance with Table 1. This table lists the period of clock signal DPH TTY CLK H versus baud rate for two adjustment ranges. For example, assume that in step 4 the baud switch was set to position 4 to select 300 baud in range 1. The corresponding clock signal period is 208 μ s. It is set by adjusting potentiometer R21 on the M7260 module, which is accessible with the module installed. The clock period is displayed on the oscilloscope. Clockwise adjustment decreases the period and counterclockwise adjustment increases the period.

NOTE

Once this adjustment is made, other baud rates within the same range can be selected by changing only the baud switch position. If the new baud rate is in the other range, steps 1 through 7 must be performed because switching ranges requires a change in the period of the clock signal.

8. Remove the oscilloscope probe, replace the mounting box top and bottom covers and push the computer back in the rack. Signal DPH TTY CLK (1) H is the output of the SCL oscillator. After the adjustment procedure is completed, the period of this signal is 26 μ s for range 1 and 35.5 μ s for range 2. This signal is accessible for observation only by extending the M7260 module and directly probing E100 pin 06.

**description of control logic
and microprogram module
M7261 revision R**

1st Edition January 1974
2nd Printing July 1974

Copyright © 1974 by Digital Equipment Corporation

The material in this manual is for informational purposes and is subject to change without notice.

Digital Equipment Corporation assumes no responsibility for any errors which may appear in this manual.

Printed in U.S.A.

The following are trademarks of Digital Equipment Corporation, Maynard, Massachusetts:

DEC	PDP
FLIP CHIP	FOCAL
DIGITAL	COMPUTER LAB
UNIBUS	

INTRODUCTION

This publication is a supplement to the *PDP-11/05, 11/10 Computer Manual* (DEC-11-H05AA-B-D). It discusses the differences between the latest M7261 Control Logic and Microprogram Module (Revision R) and previous M7261 modules. This latest module is manufactured to etch board revision F, which has a completely different layout than previous modules.

All revisions of the M7261 module are functionally interchangeable. The R revision contains several circuit improvements.

The functional operation of this module is described in Chapter 8, KD11-B Detailed Description, and Chapter 9, Microprogram Control, of the referenced manual. Because of the new layout, the component designations (E numbers) on the R revision module are different than those referenced in the *PDP-11/05, 11/10 Computer Manual*.

This supplement discusses only the significant changes that occur in the R revision. Each change is discussed as a separate item. Detailed logic prints are included in the separately supplied printed set; specifically, drawing D-CS-M7261-0-1 Revision R, Sheets 1–14.

1. Use of Resistor Network Instead of Discrete Resistors for Pull Up/Pull Down

Resistor network, part number 1311003-02, is used instead of discrete pull up resistors. It is a hybrid thick film resistor divider network in a 16-pin DIP. The package consists of 14 identical circuits (Figure 1). Each circuit consists of an R1 resistor (330 Ω) and R2 resistor (680 Ω) connected in series between +5 V and ground. Connection to the logic device is made between R1 and R2.

Six networks (E54, E82, E92, E93, E95 and E100) are used on the module. Refer to drawing D-CS-M7261-0-1, sheets 3, 4, 6, 8, 9, 10, 12, and 13.

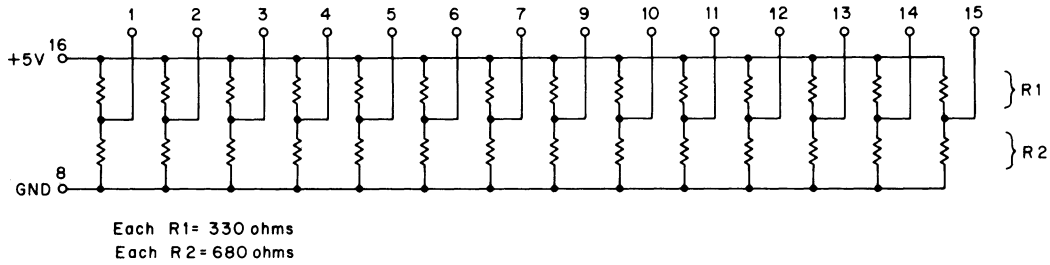

Circuit Schematic

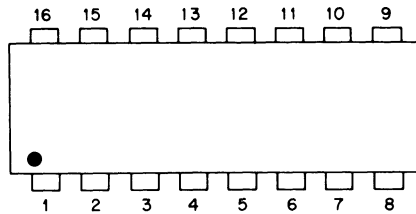

Pin Designations

11-2083

Figure 1 Resistor Network (1311003-02) Circuit Schematic and Pin Designation

2. Addition of Circuit Selectively Disables the Internal SCL Interface

A simple circuit has been added to selectively disable the internal SCL interface, if the user desires to control a serial communications device with a separate interface using the standard console addresses given below.

The circuit is shown in print CONA, which contains the internal address detection logic. For convenience, the disabling circuit is also shown in Figure 2.

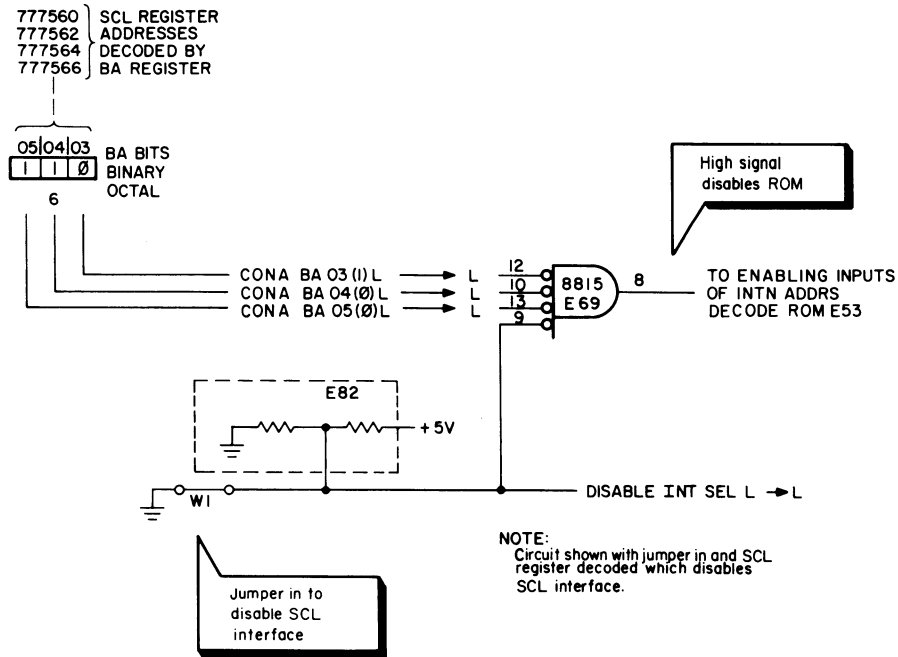

11-2419

Figure 2 SCL Interface Disabling Circuit

With jumper W1 out, the internal address detection logic operates normally. Physically, jumper W1 is located between IC packages E59 and E69 (print D-CS-M7261-0-1, sheet 2). Pin 9 of NOR gate E69 is held permanently to approximately 3.3 V via resistor network E82. This keeps the output (pin 8) of E69 low, which constantly enables the INTN ADDR DECODE ROM (E53). Four internal addresses are assigned to the Universal Asynchronous Receiver/Transmitter (UART) in the SCL interface. They are listed below.

Address	Register
777560	Receiver Status
777562	Receiver Data Buffer
777564	Transmitter Status
777566	Transmitter Data Buffer

Assume that an SCL address is loaded into the Bus Address Register (BA) that is composed of E50, E51, and E52. The low byte BA outputs are used to address the INTN ADDR DECODE ROM (E53) whose outputs are used to address the DATI ADDR DECODE ROM (E72) and the DATO ADDR DECODE ROM (E71). These ROMs generate control signals for the SCL interface.

With jumper W1 in, the internal address detection logic does not respond to any of the four SCL addresses, so the SCL interface is disabled. Pin 9 of E69 is now held low permanently because the resistor output is connected to ground via jumper W1. When the other three inputs of E69 are all low, the output (pin 8) of E69 is high and the INTN ADDR DECODE ROM (E53) is disabled, which prevents assertion of the SCL control signals. These three inputs are connected to the outputs of BA bits 05, 04, and 03 which determine the second least significant octal digit of the internal register address. As shown in Figure 2, these bits are all 0s when octal 6 is decoded in this position, which occurs only in the address of the four SCL registers.

3. Addition of Circuit to Allow Processor to Become a Slave (Parallel) Processor

A circuit has been added that allows a second KD11-B Processor in a multiprocessor system to be selected as a slave processor. As such, the processor performs its computational functions and reacts as an NPR device on the Unibus. To perform any transfer it issues NPRs to the master processor, responds to NPGs from the master, and becomes bus master. The slave cannot be interrupted; therefore, it does not respond to NPRs or BRs from other devices.

The circuit is shown in print CONB at coordinates B1–6 to C1–6, some associated logic is shown in print COND at coordinates C5–7. For clarity, portions of the circuit are shown in Figure 3. If it is desired to create a slave processor, jumper W2 (print CONB) must be installed. Physically, W2 is located between IC packages E63 and E73 (print D-CS-M7261-0-1, sheet 2). Resistor R2 (print COND) must be installed also to ensure proper Unibus termination of the NPG line. Physically, R2 is located between IC packages E11 and E21 (print D-CS-M7261-0-1, sheet 2).

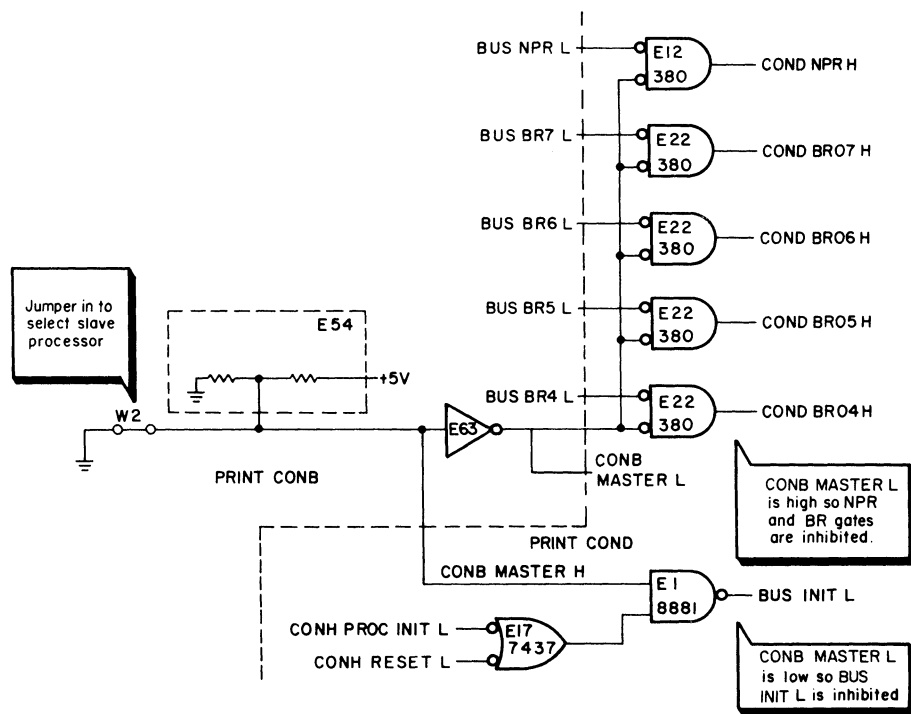

11-2420

Figure 3 Slave Processor Selection Circuit

With W2 installed, the resistor output is connected permanently to ground through the jumper. This holds CONB MASTER H low and, via inverter E63, holds CONB MASTER L high. Signal CONB MASTER L is sent to one input of five bus receivers (E12 and E22 on print COND) that are connected to BUS NPR L and BUS BR4L – BUS BR7L.

With CONB MASTER L high, these gates are inhibited and the slave processor does not respond to NPRs and BRs from other devices. Signal CONB MASTER H, which is low, is sent to bus driver E1 (print COND), which inhibits the assertion of BUS INIT L by the slave processor.

4. Changes to Unibus Control Logic

Four significant changes have been made in the Unibus control logic (print CONC). They are described below.

a. *Change To Allow BUS BBSY To Be Asserted During DATIP Transaction.*

Simple logic changes have been made to ensure that BUS BBSY L is asserted during a DATIP transaction. This guarantees that the current bus master holds the bus during the interval between the DATIP transaction and the required DATO transaction that follows it. The logic change is in the DATIP circuit (print CONC, coordinates D4–6).

When a DATIP transaction is in process, the DATIP BBSY flip-flop E4 is set and CONC DATIP BBSY (1) L is asserted. This signal is inverted by negated-input OR gate E17 (print COND, coordinates B3) to generate COND ASRT BBSY H, which is inverted by bus driver E11 (print COND, coordinates C6) to assert BUS BBSY L on the Unibus.

This action occurs if the processor is selected as slave or master. In the case of a master processor, signal CONC DATIP BBSY (0) L from the DATIP BBSY flip-flop is used in the NPG logic (print CONC1, coordinates D5 –7) to inhibit the setting of the NPG flip-flop.

In the case of a slave processor, it is also necessary to inhibit other transactions between DATIP and DATO; however, the slave has no way of inhibiting the master's NPG. Therefore, BBSY is held asserted so that even if another device is granted the bus, it cannot become bus master (assert BBSY) until the DATO transaction is complete.

b. *Change To Allow BUS BBSY To Be Asserted when Processor Is Selected As a Slave.*

The input to the BBSY flip-flop (print CONC, coordinates C2–6) has been changed. Signal CONB TAKE BUS H from the slave selection circuit is used as a qualifying input for the BBSY flip-flop. When the processor is selected as a slave and takes control of the bus, CONB TAKE BUS H is asserted. It qualifies the J input of the BBSY flip-flop so that it can be set when clocked. When it is set, CONC BBSY (1) L generates COND ASRT BBSY H which, in turn, asserts BUS BBSY L via driver E11 (print COND, coordinates C6).

c. *Change To Allow Direct Clearing of BUS MSYN L During a DATO Transaction when BUS SSYN L Is Received.*

By definition, during a DATO transaction BUS MSYN L may be cleared immediately by BUS SSYN L when it is returned by the slave device.

A simple logic change ensures this action. Gates E5 and E14 have been added to the MSYN circuit (print CONC, coordinates C2–3). During a DATO transaction, signal CONC DATO (1) H is high and is sent to pin 4 of AND gate E5. When BUS SSYN L is asserted and received, the input of E5 (pin 5) is high also, which drives the output of E5 high. This signal is sent to E14 and inhibits the assertion of CONC MSYN OUT H at its output. This low signal is sent to bus driver E40 (print COND, coordinates B6–7) to clear BUS MSYN L on the Unibus.

d. *Change To Allow Stepping Through a Timeout During Servicing with the Maintenance Board.*

Installation of the maintenance module during servicing disables the processor clock and allows it to be single-stepped. In the previous module, the disabling signal (CONJ MAN CLK L) was sent to the D input of the DAT TO flip-flop that provides an input to the bus error logic. This flip-flop is clocked by the trailing edge of a 22 μ s pulse from a one-shot that is triggered when BUS MSYN L is asserted. With the D input of the DAT TO flip-flop held low by CONJ MAN CLK L, it cannot be set to indicate that a timeout has occurred. If a problem exists in the timeout circuit, it cannot be detected during servicing with the maintenance module installed.

The change on the latest module consists of substituting CONC TOTAL SSYN L for CONJ MAN CLK L at the D input of the DAT TO flip-flop (print CONC, coordinates A5).

Now, when the maintenance module is installed, the DAT TO flip-flop is not affected. If a timeout occurs during servicing, the DAT TO flip-flop is set the same as it would be during normal operation.

5. Use of Decoder In Place of INT INTR ACK ROM In Microbranch Logic

Decoder E110 (print CONE, coordinates A5) has been substituted for the INT INTR ACK ROM (23-A13A1) that is used in the previous module. Functionally, there is no change: the decoder is just a less expensive device.

The decoder is a type 74154 which decodes 4 binary-coded inputs into 1 of 16 mutually exclusive outputs. When signal CONE BUT SERVICE L is low, the decoder is enabled. The four inputs come from the output of the BUT SERVICE ROM (E107). Only five decoder outputs are used and they are the same as those generated by the INT INTR ACK ROM on the previous module.

6. Changes In Auxiliary Control Logic

The method of generating the basic enabling signal (CONF AUX CONTROL L) for the auxiliary control mode has been changed. The pulse width of this signal has been reduced from 600 ns to 300 ns.

CONF AUX CONTROL L is now asserted one microstep earlier in this module and the processor clock is not turned off during the auxiliary control mode. Because of this change, two new ROMs are used. One is E116 (A19A2) on print CONG (coordinates D7) that asserts CONG CKOFF L. The other is E103 (A20A2) on print CONF (coordinates B7) that controls the enabling of the auxiliary control mode. When auxiliary control is desired, E103 asserts CONF PRE AUX L. This signal, via gate E80 pin 6, puts a high on the D input of flip-flop E13. The next positive transition of processor clock signal CONJ UNG PROC CLOCK L sets E13 and asserts CONF AUX CONTROL L.

The additional gating to the input of flip-flop E13 is required to accommodate enabling the auxiliary control mode during the special case of a (MOVE) (BYTE) instruction.

7. Changes In Asserting INIT During RESET Instruction

A one-shot (E48 DELAY) has been added (print CONH, coordinates B5) to delay the assertion of CONH RESET L approximately 2 μ s from the time CONE BUT INIT H is asserted as a result of a RESET instruction. This ensures adequate time for the memory to perform a restore cycle, if required, and not lose data as a result of the bus initialization action derived from a RESET instruction.

Flip-flop E13, gate E33, and gate E55 form a network to the triggering input of one-shot E48 to ensure respect for the operating rules of the Unibus. Inputs to this network are derived from Unibus signals BUS BBSY, BUS NPG, and BUS SACK. Assertion of any one of these signals prevents the one-shot from being triggered and starting the bus initialization process.

8. Change In Processor Clock Circuit

The output of the console START switch (CONSOLE START L) has been added as an enabling input for the processor clock. The signal is sent to E75 pin 5 (print CONJ, coordinates C8).

digital

DIGITAL EQUIPMENT CORPORATION
MAYNARD, MASSACHUSETTS 01754